

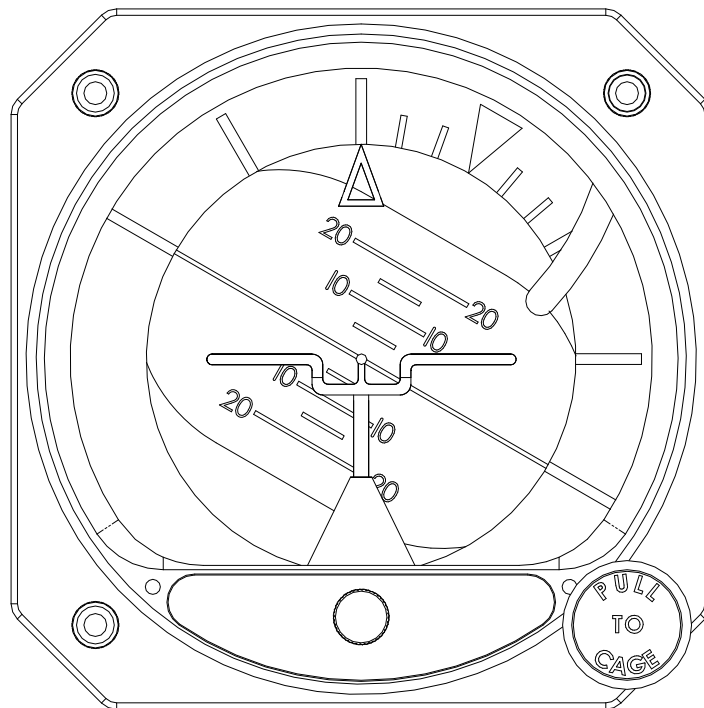

INSTALLATION MANUAL AND OPERATING INSTRUCTIONS

4300-202/-203 Series Electric Attitude Indicator



Mid-Continent Instruments and Avionics
9400 E 34th Street N, Wichita, KS 67226 USA
Phone 316-630-0101 • Fax 316-630-0723

Manual Number 9016082
REV A October 7, 2004

FOREWORD

This manual provides information intended for use by persons who, in accordance with current regulatory requirements, are qualified to install this equipment. If further information is required, please contact:

Mid-Continent Instruments and Avionics
Attn: Customer Service Dept.
9400 E. 34th ST North
Wichita, KS 67226 USA
Phone 316-630-0101 Fax 316-630-0723

We welcome your comments concerning this manual. Although every effort has been made to keep it free of errors, some may occur. When reporting a specific problem, please describe it briefly and include the manual part number, the paragraph/figure/table number, and the page number. Send your comments to:

Mid-Continent Instruments and Avionics
Attn: Technical Publications
9400 E. 34th ST North
Wichita, KS 67226 USA
Phone 316-630-0101, Fax 316-630-0723
info@mcico.com
www.mcico.com

Table of Contents

		Page
Section 1	General Description	5
1.1	Purpose of Equipment	5
1.2	Physical Description	5
1.3	Functional Description	5
1.4	Gyro Warning Flag	5
1.5	Options and Configurations	5
1.6	Specifications	6
Section 2	Installation	8
2.1	General	8
2.2	Pre-Installation Inspection	8
2.3	Parts	8
2.3.1	Included Parts	8
2.3.2	Installer Supplied Parts	8
2.3.3	Additional Optional Parts	9
2.4	Equipment Location	9
2.5	Installation	9
2.6	Continued Airworthiness	9
Section 3	Operation	12
3.1	General	12
3.2	Starting Procedures	12
3.3	In-Flight Procedures	12
3.4	Dynamic Errors	12
3.5	Equipment Limitations	13
Figure No.	List of Illustrations	
1.1	Typical Indicator Display Detail	7
2.1	Outline Drawings	10
2.2	Rear-Mount Cutout Dimensions	11
2.3	Front-Mount Cutout Dimensions	11
Table No.	List of Tables	
1.1	Configuration Table	5
1.2	Physical Characteristics	6
1.3	Performance	6

Revision Detail

<u>ECO</u>	<u>Rev.</u>	<u>Date</u>	<u>Description</u>
	A	10/7/04	Initial Release

Section 1: General Description

1.1 Purpose of Equipment

The Model 4300-202/-203 Electric Attitude Indicator incorporates a moving display that simulates the earth's horizon and provides the pilot with a real time visual indication of the aircraft pitch and roll attitude relative to the indicator symbolic airplane.

The instrument can function as a primary or standby indicator with special configurations available to match existing systems or electronic flight displays.

1.2 Physical Description

The 4300-202/-203 Electric Attitude Indicator incorporates pitch and roll displays that are mechanically linked to a spinning mass gyroscope. The horizon bar moves behind the symbolic airplane. Precession error is corrected by the 4300's erection system or by pulling the "PULL TO CAGE" knob. A warning flag drops into view to indicate that the gyro motor is not receiving sufficient power to operate.

1.3 Functional Description

Model 4300-202/-203 Electric Attitude Indicators employ an efficient electrically driven internal vertical gyroscope assembly incorporating a special air erection mechanism. This mechanism simultaneously erects the pitch and roll axes of the gyroscope. Movement of the aircraft generates a reaction of the display that simulates the visual reference seen by the pilot when looking outside at the earth's true horizon line.

The Indicator requires 10 to 32 VDC input voltage.

1.4 Gyro Warning Flag

A power warning circuit monitors the electrical current used to power the gyro motor. When a loss of input voltage occurs, the gyro warning flag comes into view.

1.5 Configuration

Configuration Table		
	4300-202	4300-203
Panel Tilt Calibration	11°	11°
Input Voltage	10-32 VDC	10-32 VDC
Roll Dial	Rotating	Rotating
Symbolic Airplane	Traditional	Traditional
Lighting	Not included	Not included
Slip Indicator	Not included	Included

Table 1.1

Mid-Continent Instruments and Avionics, Wichita, KS

1.6. Specifications

Physical Characteristics:	
Qualification:	FAA-TSO-C4c
Environmental Qualification:	RTCA DO-160D Environmental Category A2BAB[(SBM)(RBB1)]XXXXXXZZAZZ[RR]M[A3C3]XXA
Weight:	2.4 pounds
Dimensions:	Length behind panel (not including connector) 6.6 inches long maximum. 3.28 inches high maximum. 3.28 inches wide maximum.
Mating Connector:	MS3116F8-4S or equiv. (not supplied with unit)
Cover Glass	HEA (anti-reflective) coated.
Instrument Panel Mounting:	Rear mount. Front mount with adapter plate.

Table 1.2

Performance:	
Reliability	7500 Hour Mean Time Between Failures (MTBF)
Initial Erection:	The "PULL TO CAGE" knob will erect the gyroscope to within 2.0° of case vertical in roll and pitch from any position at any time.
Final Erection:	The vertical gyroscope should be allowed to spin up for 3 minutes after rated power is applied and after initial erection. After 5 minutes the final erection accuracy of pitch and roll will be within 1° of vertical.
Erection Rate:	Gyroscope will erect to local vertical in pitch and roll at 2.5° per minute minimum.
Warning Flag:	A gyro warning circuit provides for continuous monitoring of gyro voltage. If loss of gyro motor voltage occurs, the red warning flag will appear.
Symbolic Airplane:	The adjustment range will be ± 4° minimum from the zero pitch position.
Power Consumption:	
Starting:	Will not exceed 1.5A at 14 VDC. Will not exceed 0.7A at 28 VDC.
Running:	Nominal 0.55A ±15% at 14 VDC. Nominal 0.27A ±15% at 28 VDC.

Table 1.3

Mid-Continent Instruments and Avionics, Wichita, KS

- Roll Pointer:** Fixed roll pointer: Indicates aircraft roll displacement relative to a rotating roll dial.
- Gyro Warning Flag:** If loss of input voltage should occur, gyro warning flag will come into view.
- Display:** Lower area of display, when referenced to the symbolic airplane, indicates aircraft nose is below horizon or in a dive attitude. Upper area of display indicates aircraft nose is above horizon or in a climb attitude.
- Symbolic Airplane:** Indicates roll and pitch attitude relative to the horizon. The symbolic airplane can be moved (pitch only) using the symbolic airplane adjustment knob.
- Horizon Line:** Indicates earth horizon relative to aircraft pitch and roll attitude.
- Caging knob:
(Manual Erection)** When pulled, manually erects the gyro vertical to the case orientation.
- Symbolic Airplane
Adjustment Knob:** Used to adjust the symbolic airplane.

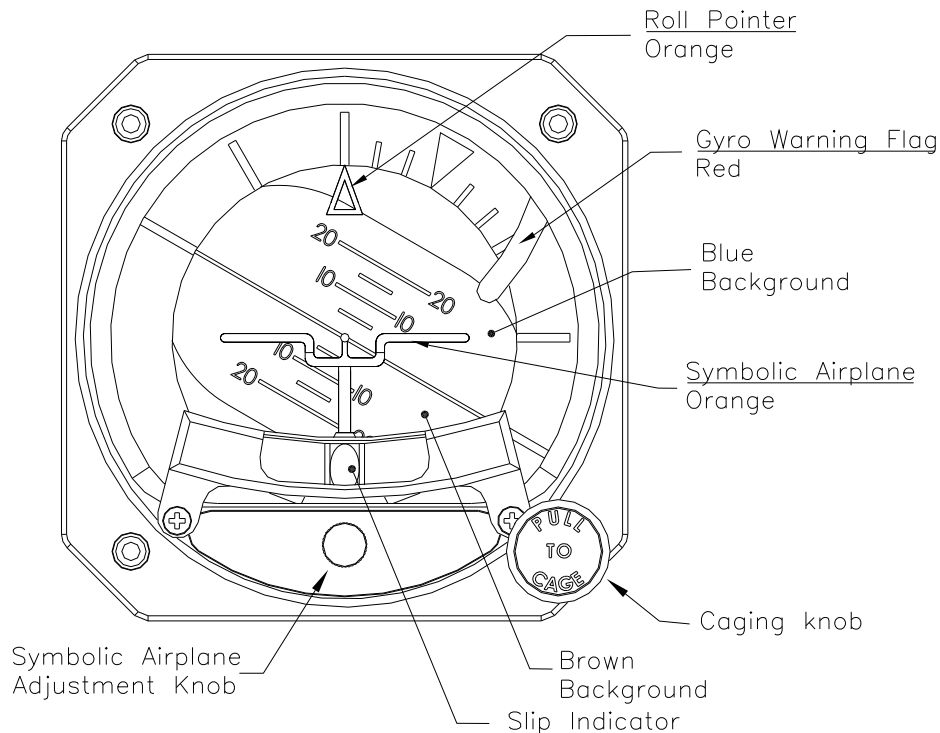

Typical Electric Attitude Indicator Display
(Rotating Roll Dial, Fixed Roll Pointer, Traditional Wing Symbolic Airplane Shown)

Figure 1.1

Section 2: Installation

2.1 General

This section contains mounting, electrical connections and other information required for installation. After installation of cabling and before installation of the equipment, ensure that power is applied only to the pins specified in the interconnection diagram.

CAUTION: GYROS ARE DELICATE INSTRUMENTS! THE FOLLOWING PRECAUTIONS MUST BE OBSERVED!!

- A. A high gyroscope failure rate can be directly related to rough or improper handling. Gyros are delicate and cannot withstand the shock of being dropped, jarred, or struck by pieces of equipment. Do not place gyros on any hard surface. Pad with generous foam. Handle like eggs!
- B. To prevent damage to a gyro, the instrument should be transported to and from the aircraft in it's original shipping container. If this is impractical, the gyro should be hand-carried carefully in an upright position.
- C. A gyro should never be removed while it is spinning or running down. The instrument normally operates at high RPM and may take 10 minutes or longer to run down. If it is removed while running and tilted more than 20 degrees, the gyro can develop a gimbal lock. The gimbal will tumble and start to spin. If gimbal lock occurs while the rotor is turning, the gimbal may spin fast enough to damage the gimbal bearings, requiring overhaul.
- D. A malfunctioning gyro should be handled with the same care given a new instrument. Most malfunctioning instruments can be repaired and returned to service. Using proper handling procedures during removal prevents additional damage and helps ensure possible reuse.

2.2 Pre-installation Inspection

- A. Unpacking
Carefully remove Attitude indicator from shipping container. The shipping container and packing materials should be retained for use should the attitude indicator require future shipment.
- B. Inspect for Damage
Inspect the shipping container and attitude indicator for any signs of damage sustained in transit. If necessary, return attitude indicator to the factory using the original shipping container and packing materials. File any claim for damages with the carrier.

2.3 Parts

2.3.1 Installer Supplied Parts

- A. Mounting Screw, 6-32UNC-2A. Three (3) required. (1" long screws are suggested for panel thickness between 0.05 and 0.19, but may not be optimum in some installations. The installer will need to determine what is correct for a particular installation.) **CAUTION: Do not exceed 1.06" screw depth into bezel!**
- B. Mating Connector, MS3116F8-4S or equivalent (P/N 9015514)

2.3.2 Additional Parts that may be required

- A. Symbolic Airplane Adjustment Knob Cover Kit: (P/N 36022)
- B. Slip Indicator Kit (P/N 36023)
- C. Front Mount Kit: 3/32" thk (P/N 36028-1) or 1/2" thk (P/N 36027-1)
- D. Panel Wedges: 3" (P/N PW3R-3) or 4" (P/N PW3R-4)

2.4 Equipment Location

The attitude indicator should be located within the aircraft in accordance with the following considerations:

- A. The indicator is ideally located in the instrument panel directly in line with the pilot's normal line of sight. The "PULL TO CAGE" knob should be within easy reach. Installations that result in viewing angles in excess of 30 degrees may reduce display readability.
- B. Compare the space requirements of the indicator with the installation area being considered.
- C. The power cable should not run adjacent to heaters, engine exhausts, or other heat sources. Also, take care to route and tie the cable away from aircraft controls and cables.

2.5 Installation

NOTE: Before installing unit, verify the Options decal on the unit matches the aircraft requirements for instrument voltage and panel tilt.

Install the Electric Attitude Indicator within the aircraft in accordance with the aircraft manufacturer's instructions and the following steps:

- A. Refer to Figure 2.1 for installation dimensions and electrical information.
- B. Ensure the available instrument panel cutout meets the requirements of the indicator. See Fig 2.2 or Fig 2.3 for details.
- C. Attach aircraft electrical system cable to indicator connector and insert the indicator into the instrument panel cutout.
- D. Secure the indicator to the instrument panel using the screw sizes called out in the mounting instructions. Length of screws will be determined by aircraft instrument panel thickness. The aircraft manufacturer or the installation facility is responsible for supplying appropriate installation hardware.
- E. Apply the correct input power to the indicator.
- F. The Gyro Warning flag (red) will be out-of-view.

2.6 Continued Airworthiness

No periodic scheduled maintenance or calibration is necessary for continued airworthiness of the 4300 series Electric Attitude Indicator. If the unit fails to perform to specifications, it must be removed and serviced by a qualified service facility.

Mid-Continent Instruments and Avionics, Wichita, KS

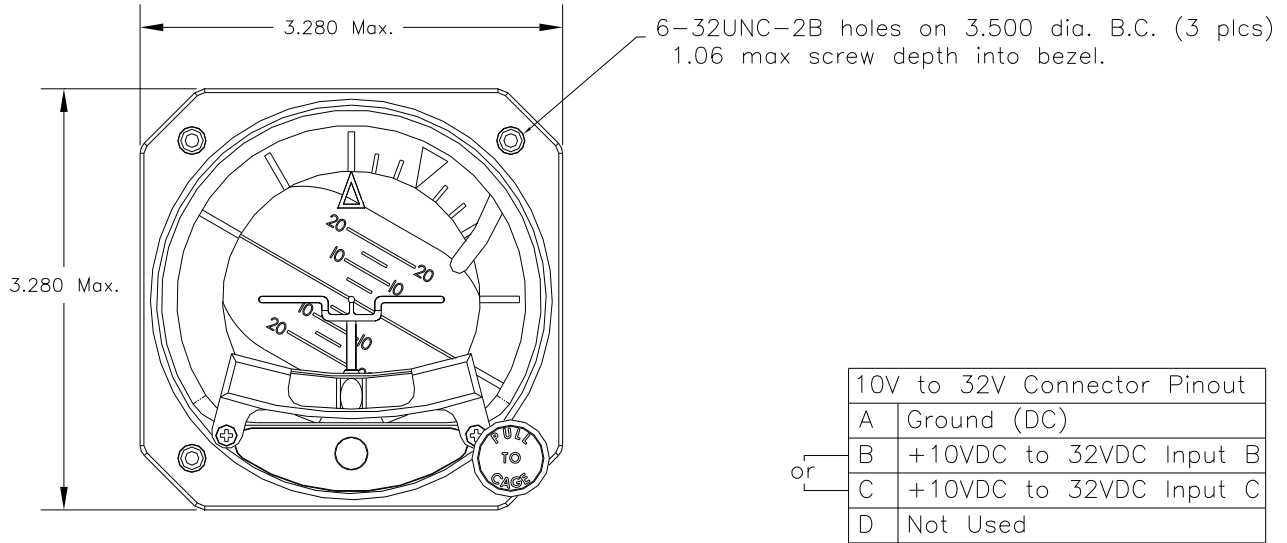

Note:

- 1) Recommended Circuit Breaker: 2 Amp for 14VDC aircraft and 1 Amp for 28VDC aircraft.
- 2) Wire gauge shall be 22 AWG minimum.

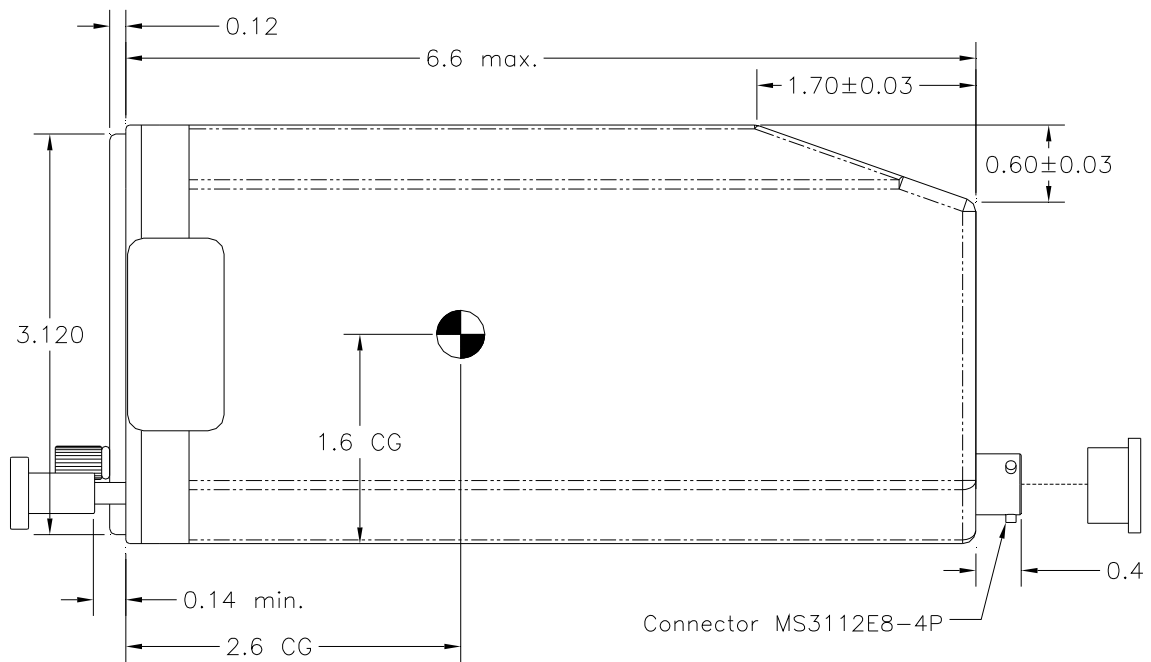

Figure 2.1 Outline Drawing

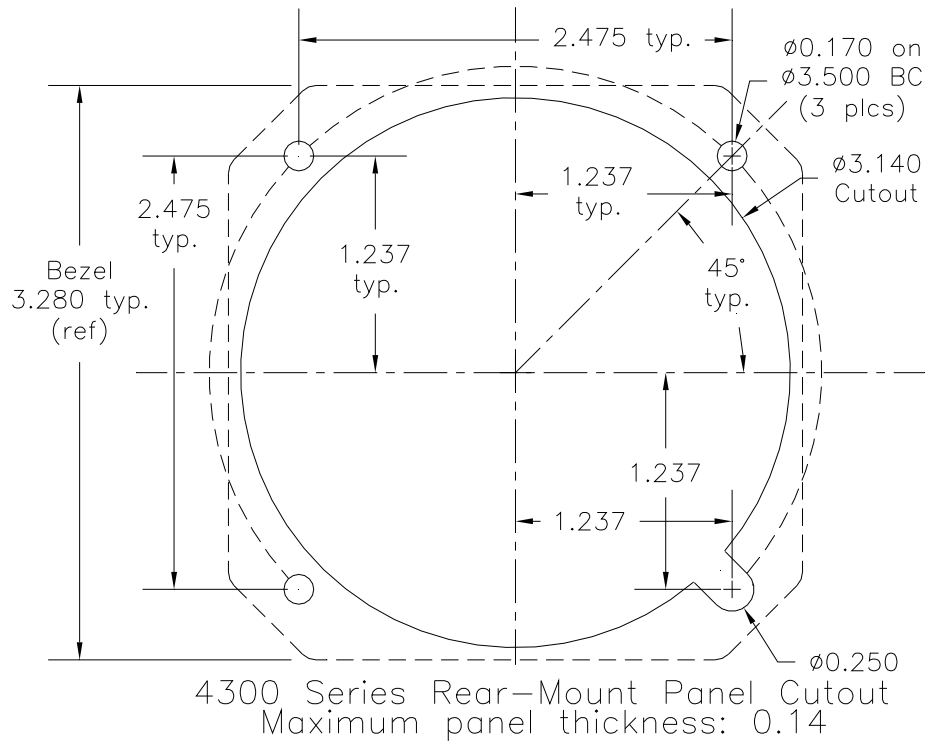

Figure 2.2: Panel Cutout Dimensions

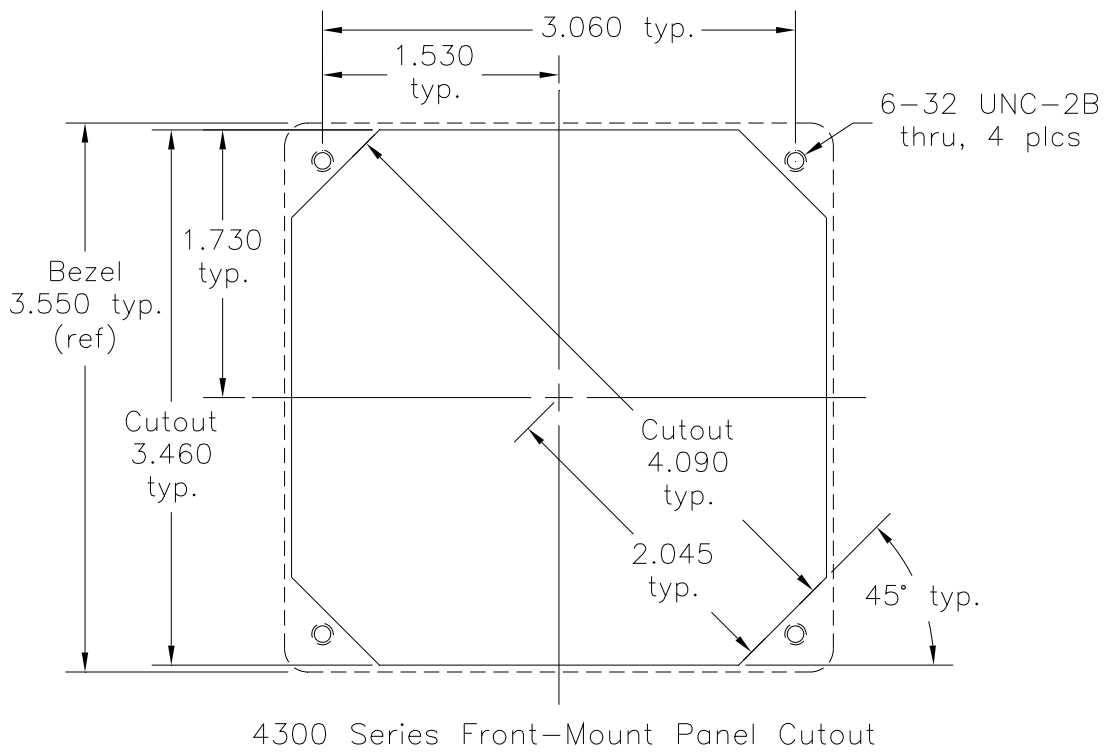

Figure 2.3: Front Mount Panel Cutout Dimensions

Section 3: Operation

3.1 General

This section describes the Model 4300-202/-203 Electric Attitude Indicator operating procedures. The indicator is required to be installed in an aircraft with the specified inputs applied. Figure 1.1 provides an illustration of a typical Model 4300 display and a table describing indicator functions.

3.2 Starting Procedures

The following operational procedures are recommended when preparing the indicator for use:

CAUTION: THE INDICATOR MAY BE DAMAGED IF THE "PULL TO CAGE" KNOB IS RELEASED WITH A "SNAP." RELEASE "PULL TO CAGE" KNOB AVOIDING A "SNAP" RELEASE.

NOTE: Indicator may be momentarily caged by pulling "PULL TO CAGE" knob to the fully extended position, holding knob until the display stabilizes, and then allowing the knob to return to the normal position.

- A. Apply power to the indicator. Note that the Gyro Warning flag (red) will pull out-of-view. Also allow three minutes for presentation stabilization.
- B. On models with trim adjustment, rotate the symbolic airplane adjustment knob for the desired pitch attitude presentation, i.e. aligning the symbolic airplane with the horizon.
- C. If caging is required, caging should be accomplished when the aircraft is in a wings level, normal cruise attitude, as indicated by other instruments or the horizon. If the gyro is caged when the aircraft is not in this attitude, the resulting attitude presentation immediately after caging will be in error by the difference between true vertical and actual aircraft attitude. Small errors in caging erection will be corrected by the indicator to true vertical in pitch and roll at 2.5° per minute minimum (5°/min. nominal).

3.3 In-Flight Procedures

- A. Adjust the symbolic airplane to obtain desired pitch attitude presentation after take-off.
- B. In the event of errors in excess of 10° caused by extended bank or fore-aft acceleration, the indicator should be momentarily caged after the aircraft is returned to level flight.

3.4 Dynamic Errors

- A. Turn Induced Errors

Pitch indication errors resulting from a standard coordinated turn (180 degrees in one minute at a true airspeed of 156 knots) will not exceed 3°. Dynamic errors developed under non-standard conditions may be greater. Errors that develop will be self corrected by the internal erection system or manually corrected by the actuation of the caging system in straight and level flight.

Mid-Continent Instruments and Avionics, Wichita, KS

B. Acceleration & Deceleration Errors

Pitch indicating errors may occur due to accelerations experienced during takeoff, climb-out, descent, and landing. Errors that develop will be self-corrected by the internal erection system or manually corrected (in straight and level flight) by the actuation of the caging system.

C. Taxiing Errors

A pitch and roll indicator display error of approximately 1° will occur during a sudden 90° ground turn. A pitch indicator display error of approximately 2° will occur during a sudden 180° ground turn. Errors that develop will be self corrected by the internal erection system or manually corrected by the actuation of the caging system when aircraft is straight and level.

3.5 EQUIPMENT LIMITATIONS

The 4300-202/-203 series Electric Attitude Indicator is not to be used as a reference for aerobatic flight. It is recommended to turn off the Attitude Indicator (red flag showing) at least 5 minutes before aerobatic maneuvers are initiated.