

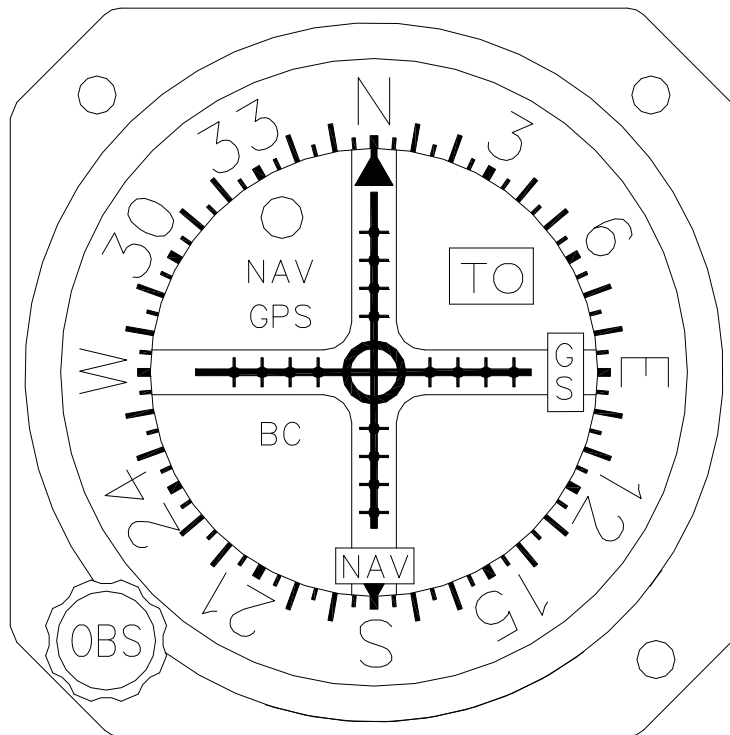

INSTALLATION MANUAL AND OPERATING INSTRUCTIONS

MD200-302/303/306/307 Series COURSE DEVIATION INDICATOR



Mid-Continent Instruments and Avionics
9400 E. 34th Street N. Wichita, KS 67226 USA
Phone 316-630-0101 • Fax 316-630-0723

Manual Number 8017972
REV. 3 Dec. 15, 2003

Revisions

Rev.	Date	Description of Change	ECO#
1	8/11/00	Corrected typographical errors, added section 4.2 Annunciator Dimming Adjustment	---
2	4/11/02	Added MD200-302(5V), -303(5V), -306(5V), -307(5V) indicators. These units have 5 volt bezel lighting.	---
3	12/15/03	Corrected 5 volt lighting connections to J1	---

TABLE OF CONTENTS

SECTION 1	GENERAL DESCRIPTION
1.1	INTRODUCTION
1.2	SPECIFICATIONS, TECHNICAL
1.2.1	PHYSICAL CHARACTERISTICS
1.2.2	ENVIRONMENTAL CHARACTERISTICS
1.2.3	SPECIFICATIONS, ELECTRICAL
1.2.4	FRONT PANEL CONTROLS
1.2.4.1	CONTROLS
1.2.4.2	ANNUNCIATIONS
1.2.5	INTERFACE
1.2.6	EQUIPMENT LIMITATIONS
1.2.7	MAJOR COMPONENTS
SECTION 2	INSTALLATION CONSIDERATIONS
2.1	COOLING
2.2	EQUIPMENT LOCATION
2.3	ROUTING OF CABLES
SECTION 3	INSTALLATION PROCEDURE
3.1	GENERAL INFORMATION
3.2	UNPACKING AND INSPECTING
3.3	MOUNTING THE MD200-()
3.4	INSTALLATION LIMITATIONS
SECTION 4	POST INSTALLATION CHECKOUT
4.1	PRE-INSTALLATION TEST
4.2	OPERATING INSTRUCTIONS
FIGURE NO.	LIST OF ILLUSTRATIONS
3.1	MATING CONNECTORS
3.2	CUTOUT DEMENSIONS FOR PANEL MOUNTING
3.3	MD200-302/303/306/307 SERIES OUTLINE DRAWING
3.4	MD200-306/307 SERIES WIRING DIAGRAM
3.5	MD200-302/303 SERIES WIRING DIAGRAM

APPENDIX

ENVIRONMENTAL QUALIFICATION FORM

SECTION 1 GENERAL DESCRIPTION

1.1 INTRODUCTION

The Mid-Continent Instruments and Avionics MD200-302/303/306/307 Nav Indicator is designed to operate with VHF, and GPS navigational equipment to provide OMNI (VOR), GPS, LOCALIZER (LOC) and Glideslope (GS) information.

The MD200-302/303 is designed to accept DC Left-Right, To-From and Nav warn flag signals from a remote mounted VOR converter. Additionally, the MD200-306/307 will accept DC signals from a glideslope receiver which will drive the UP-DOWN needle along with a GS warn meter. Both units incorporate NAV, GPS and BC annunciation with photocell dimming.

When GPS is selected for display, the MD200-() receives inputs from compatible GPS/navigation receivers or Flight Management Systems to provide a visual presentation to the pilot. All information presented on the navigation indicator is generated from this external receiver.

Course datum information is offered on the MD200-303 and -307 versions. The course resolver is ORZ zero'ed to industry standard 300 deg.

Five volt bezel lighting is offered with the MD200-302(5V), -303(5V), -306(5V), -307(5V) indicators.

1.2 SPECIFICATIONS, TECHNICAL

1.2.1 PHYSICAL CHARACTERISTICS MD200-302/303/306/307

Size	3 1/8 inch Round
Mounting:	Panel
Width:	3.25 Inches
Height:	3.25 Inches
Depth:	4.75 Inches max
Weight:	MD200-302 1.4 lbs.
	MD200-303 1.5 lbs.
	MD200-306 1.4 lbs.
	MD200-307 1.5 lbs.

1.2.2 ENVIRONMENTAL CHARACTERISTICS

TSO Compliance:	TSO C34e, C36e, C40c
Applicable Documents:	RTCA DO-160B, DO-192, DO-195, DO-196
Operating Temperature Range:	-55°C to +70°C
Humidity:	95% Non-Condensing
Altitude Range:	0 to 55,000 ft.
Vibration:	Cat. M and N
Operational Shock:	Rigid Mounting, 6 G Operational 15 G Crash Safety.

1.2.3 SPECIFICATIONS, ELECTRICAL

1.2.3.1 GENERAL

DESIGN:	All Solid State
OPERATING CURRENT:	
MD200-302	0.30 Amps
MD200-303	0.30 Amps
MD200-306	0.30 Amps
MD200-307	0.30 Amps

1.2.3.2 VOR/LOC/GPS:

OBS RESOLVER:	Electrical zero: 300 degrees, ORZ.
DEVIATION:	Input impedance: 1K ohms +-10%. Deflection sensitivity: 150mV +-10% for full scale deflection.
VALID FLAG:	Input impedance: 1K ohms +-10% Flag sensitivity: 125mV +10% for flag to leave stop, 260mV +-10% maximum, flag fully concealed
TO/FROM FLAG:	200 ohms +-10%. +-40mV +-15% at 25°C flag fully in view.
COURSE DATUM: MD200-303, -307	
	Standard Arinc X, Y, Z 11.8 VRMS .030 Amp, 400 Hz

1.2.3.3 GLIDESLOPE: MD200-306, -307 only

DEVIATION:	Input Impedance: 1K ohms +/-10% Deflection sensitivity: 150mV +/-10% for full scale deflection.
VALID FLAG:	Input Impedance: 1K ohms +/-10% Flag sensitivity: 125mV +10% for flag to leave stop. 260mV +/- 10% maximum flag fully concealed.

1.2.4 FRONT PANEL CONTROLS

1.2.4.1 CONTROLS:

OBS:	Used to select appropriate inbound or outbound bearing to a VOR station or waypoint.
------	--

1.2.5 INTERFACE:

NAV/LOC/GPS:	Receives vertical, lateral deviation, warn flags TO/FROM and OBS resolver information from the GPS/NAV receiver.
GLIDESLOPE:	Receives GS up-down and warn flag input from glideslope receiver.

1.2.6 EQUIPMENT LIMITATIONS

REQUIREMENTS FOR TSO'D VOR/ILS SYSTEM:

1. The navigation receiver shall be certified to the standards of TSO C40a/b/c or TSO C36c/d/e.
2. VOR phase error shall not exceed 1.5 degrees.
3. Variation in VOR composite output not to exceed ± 3 dB from .500VRMS as the RF input level of a standard VOR test signal to the receiver is varied from 10uV to 10,000uV.
4. Variation in the LOC composite output not to exceed ± 2 dB from .333VRMS as the RF input level of a standard localizer test signal to the receiver is varied from 50uV to 10,000uV.
5. A control line (ILS Energize) must be provided as a low impedance to ground when an ILS frequency is selected.

REQUIREMENTS FOR TSO'D GLIDESLOPE SYSTEM:

1. The glideslope receiver/converter shall be certified to the standards of TSO C34c/d/e.
2. The centering error as presented to the pilot shall not exceed 13% of standard deflection with a 95% probability under all combinations of the service conditions listed in RTCA paper DO-192.
3. Deviation current with a 700uV standard glideslope deviation signal applied to the receiver input shall be 78uA $\pm 10\%$ into a 1000 ohm load. Deviation current shall not change more than 15% as the RF level of a standard glideslope deviation signal is varied from 100 to 10,000uA. Deviation current shall be proportional within 5% to the difference in depth of modulation of the 90Hz and 150Hz tones.
3. Warning signal output shall be a DC current less than 125uA into a 1000 ohm load for a warning flag to be fully visible. Warning signal for a fully concealed warning flag shall be a DC current of 260uA minimum into a 1000 ohm load.

1.2.7 MAJOR COMPONENTS

The system is comprised of one major component, the MD200-() Course Deviation Indicator.

SECTION 2 INSTALLATION CONSIDERATIONS

2.1 COOLING

No direct cooling is required. As with any electronic equipment, overall reliability may be increased if the MD200-() is not located near any high heat source or crowded next to other equipment.

2.2 EQUIPMENT LOCATION

The MD200-() course deviation indicator must be mounted as close to the pilot's field of view as possible. The unit depth, with connector attached, must also be taken into consideration.

2.3 ROUTING OF CABLES

Care must be taken not to bundle the MD200-() logic and low level signal lines with any high energy sources. Examples of these sources include 400 HZ AC, Comm, DME, HF and transponder transmitter coax. Always use shielded wire when shown on the installation print. Avoid sharp bends in cabling and routing near aircraft control cables.

SECTION 3 INSTALLATION PROCEDURES

3.1 GENERAL INFORMATION

This section contains interconnect diagrams, mounting dimensions and other information pertaining to the installation of the MD200-(). After installation of cabling and before installation of the equipment, ensure that power is applied only to the pins specified in the interconnect diagram.

3.2 UNPACKING AND INSPECTING EQUIPMENT

When unpacking equipment, make a visual inspection for evidence of damage incurred during shipment. The following parts should be included:

1. MD200-() Series course Deviation Indicator
2. Connector Kit (9 pin). MCI P/N 8017287 (-303, 307 only)
3. Connector Kit (25 pin). MCI P/N 7014517
4. Installation Manual. MCI P/N 8017972

3.3 MOUNTING THE MD200-() INDICATOR

Plan a location in the aircraft for the MD200-() course deviation indicator to be mounted as close to the pilot's field of view as possible. Avoid mounting close to heater vents or other high heat sources. Allow a clearance of at least 3 inches from back of unit for plug removal.

The indicator is secured in place behind the panel since it is designed for rear mount only. Make a panel cutout as shown in Figure 3.2. Secure the indicator in place with three 6-32 x 1.0" flat head phillips screws.

3.4 INSTALLATION LIMITATIONS

Wire the aircraft harness according to the appropriate figure. Use at least 24 AWG wire for all connections. You **MUST** use shielded wire where shown by the receiver manufacture. Avoid sharp bends and routing cable near high energy sources. Care must be taken to tie the harness away from aircraft controls and cables.

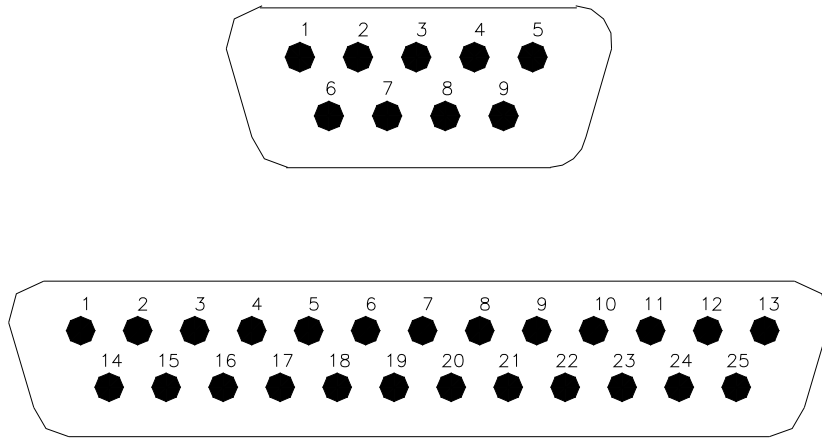

FIGURE 3-1 REAR VIEW OF MATING CONNECTORS

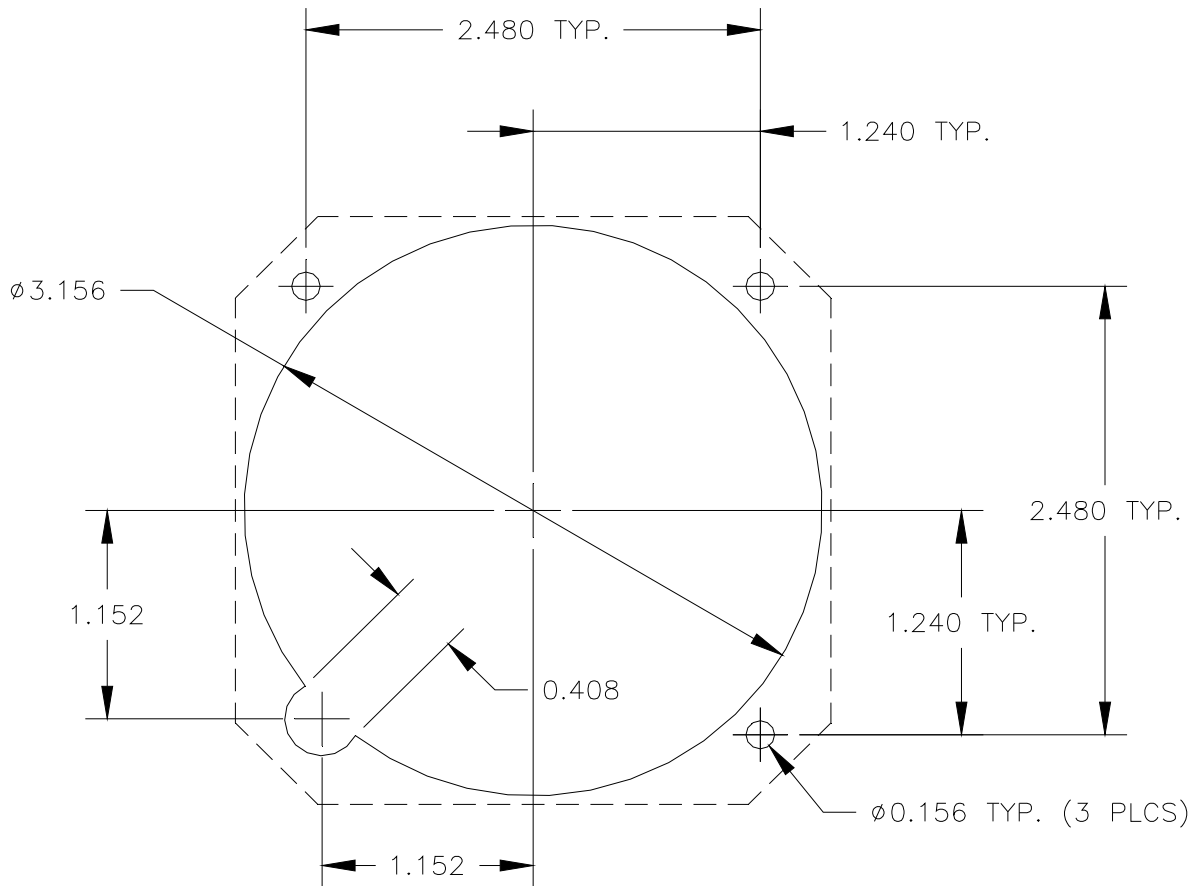
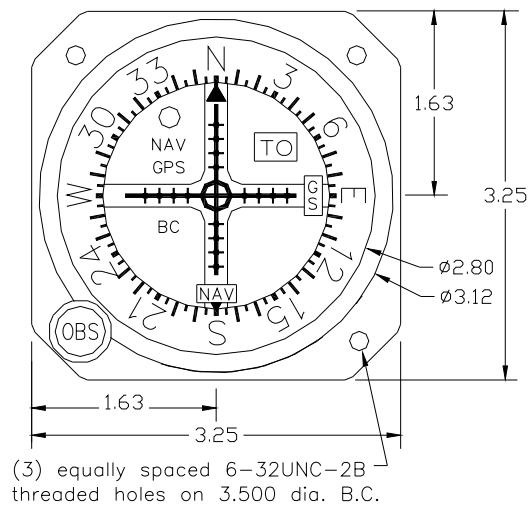
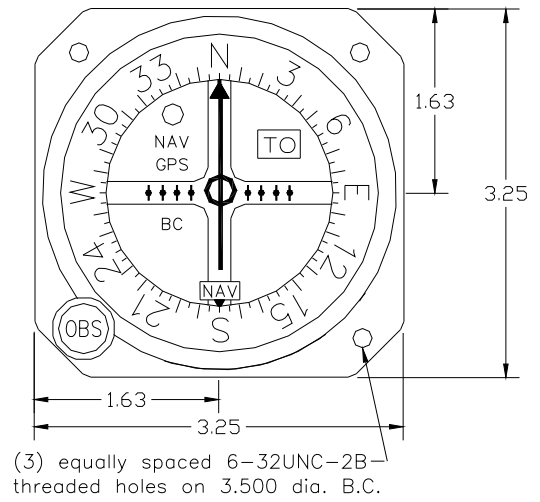

FIGURE 3-2 CUTOUT DIMENSIONS FOR PANEL MOUNTING



MD200-306/307



MD200-302/303

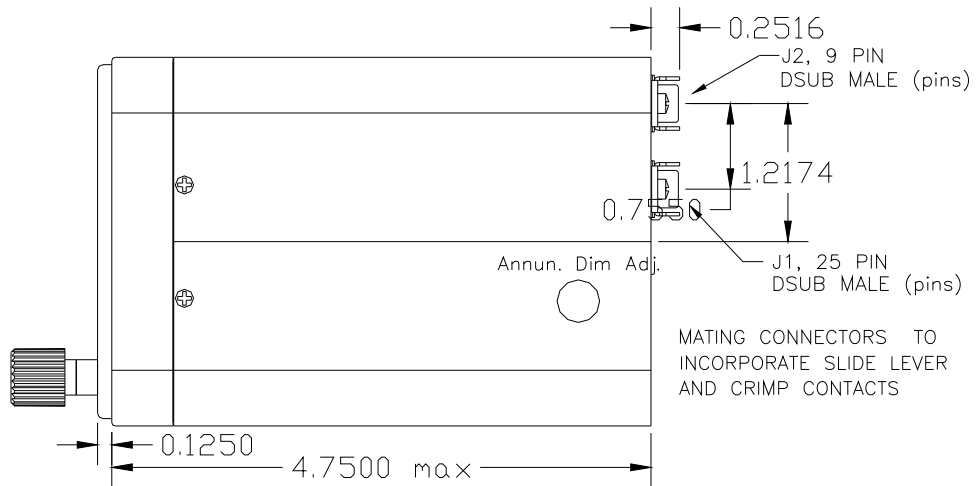

FIGURE 3-3 OUTLINE DRAWING

J1 (25 PIN D-SUB)

1	RESOLVER H
2	RESOLVER C
3	RESOLVER D
4	RESOLVER F
5	RESOLVER E
6	RESOLVER G
7	+ CDI (NAV) FLAG
8	- CDI (NAV) FLAG
9	+ TO
10	+ FROM
11	+ LEFT
12	+ RIGHT
13	SPARE
14	SPARE
15	SPARE
16	SPARE
17	GPS ANNUNCIATOR (gnd = active)
18	BC ANNUNCIATOR (gnd = active)
19	ANN POWER, 14VDC
20	ANN POWER, 28VDC
21	POWER GROUND/LIGHTING GROUND
22	28 VOLT DIMMER *
23	14 VOLT DIMMER
24	NAV ANNUNCIATOR (gnd = active)
25	5 VOLT DIMMER **

* GROUND FOR 14 VOLT LIGHTING
 ** 5 VOLT FOR MD200-302(5V) AND -303(5V) ONLY

COURSE DATUM
(MD200-303 ONLY)

J2 (9 PIN D-SUB)

1	H
2	C
3	X
4	Z
5	Y
6	SPARE
7	SPARE
8	SPARE
9	SPARE

FIGURE 3-4 WIRING DIAGRAM, MD200-302/303

J1 (25 PIN D-SUB)

1	RESOLVER H
2	RESOLVER C
3	RESOLVER D
4	RESOLVER F
5	RESOLVER E
6	RESOLVER G
7	+ CDI (NAV) FLAG
8	- CDI (NAV) FLAG
9	+ TO
10	+ FROM
11	+ LEFT
12	+ RIGHT
13	+ UP
14	+ DOWN
15	+ VERT (GS) FLAG
16	- VERT (GS) FLAG
17	GPS ANNUNCIATOR (gnd = active)
18	BC ANNUNCIATOR (gnd = active)
19	ANN POWER, 14VDC
20	ANN POWER, 28VDC
21	POWER GROUND/LIGHTING GROUND
22	28 VOLT DIMMER *
23	14 VOLT DIMMER
24	NAV ANNUNCIATOR (gnd = active)
25	5 VOLT DIMMER **

* GROUND FOR 14 VOLT LIGHTING
 ** 5 VOLT FOR MD200-306(5V) AND -307(5V) ONLY

COURSE DATUM
(MD200-307 ONLY)

J2 (9 PIN D-SUB)

1	H
2	C
3	X
4	Z
5	Y
6	SPARE
7	SPARE
8	SPARE
9	SPARE

FIGURE 3-5 WIRING DIAGRAM, MD200-306/307

SECTION 4 POST INSTALLATION CHECK

4.1 PRE INSTALLATION TESTS

With the MD200-() disconnected, turn on the avionics master switch and verify that aircraft power on J1 pin 19 is 14Vdc or pin 20 is 28Vdc. Using an ohmmeter, verify pin 21 is aircraft ground.

4.2 ANNUNCIATOR DIMMING ADJUSTMENT

Following installation of the MD200-() CDI, check the brightness of the GPS, NAV and BC annunciations as necessary with the ambient and aircraft panel lighting levels set to simulate minimum-light operations. If required, the dimming adjustment is located on the side of the MD200-() unit, and is labeled “ANNUN DIM ADJ”.

4.3 OPERATING INSTRUCTIONS

All controls required to operate the MD200-() course deviation indicator are located on the unit's front panel and on the front panel of the related navigation receiver.

4.3.1 VOR OPERATION

Channel the NAV receiver to the desired VOR frequency and positively identify the station by listening to received audio. Determine the NAV warning flag is out of view.

Flying inbound to a VOR station is accomplished by first rotating the OBS knob to center the deviation indicator, and determining the TO-FROM meter is in the TO condition. The aircraft is then turned to a magnetic heading which is the same as the selected course with proper allowance for wind correction. When the aircraft is on course, the vertical pointer will be centered. If the aircraft moves off course, the deviation indicator will move away from the center position and flying in the direction of pointer deflection (left or right) is required to re-intercept the course.

The procedure for flying outbound from a VOR station is the same as flying inbound, except the OBS knob is first rotated to cause a “FROM” indication to appear with the pointer centered.

To intercept a selected VOR radial (from the station) and fly outbound, turn the OBS control to set the desired radial under the top indicator index. Maneuver the aircraft to fly the selected radial magnetic heading plus 45° intercept angle which will provide a sufficient intercept angle. The intercept angle should be reduced as the deviation needle approaches an on course condition (center) to prevent excessive course bracketing.

4.3.2 LOCALIZER OPERATION

Select the desired localizer frequency and observe that the localizer warning flag is concealed. The TO-FROM flag is not functional for localizer operation. When flying on the front course or outbound on the back course make corrections toward the localizer (vertical) needle deflection. The localizer path narrows as the approach end of the runway becomes closer. When flying inbound on the back-course or outbound on the front course, the corrections are made away from the direction of needle deflection. A helpful hint when flying the localizer is to set the localizer heading on the OBS dial under the lubber line for quick reference.

4.2.3 GLIDESLOPE OPERATION

The glideslope (horizontal) needle provides the pilot with vertical steering information during ILS approaches. The glideslope circuitry is energized when the associated localizer frequency is selected on the navigation receiver. Observe that the glideslope warning flag is concealed. The glideslope needle deflects towards the direction the pilot must fly to remain on the glide path.

If the glideslope needle deflects upward the aircraft is below the glide path and the pilot must climb to again intercept the glide path and center the needle. If the needle deflects downward the aircraft is above the glide path and the pilot must descend to again intercept the glide path and center the needle. When the needle is centered the aircraft is on the glide path.

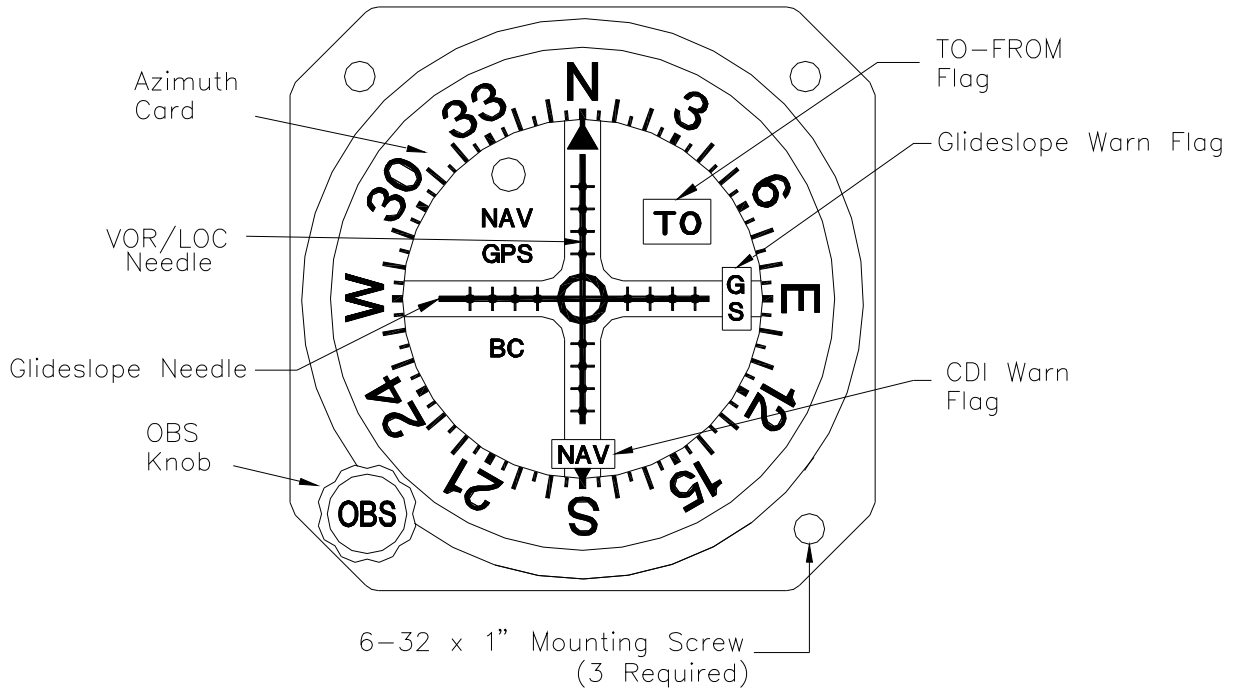

ENVIRONMENTAL QUALIFICATION FORM

RTCA / DO160B

NOMENCLATURE: MD200-() COURSE DEVIATION INDICATOR

MODEL NO: MD200-()

TSO NO: C34e
C36e, C40c

MANUFACTURER TEST SPECIFICATION:

MPS 8014565

MANUFACTURER: Mid-Continent Instruments and Avionics
9400 E. 34th Street N.
Wichita, KS 67226
Phone (316) 630-0101

Conditions	Section	Description of Conducted Tests
Temperature and Altitude	4.0	Equipment tested to Categories F2 except as noted Not Tested Not Tested
Low Temperature	4.5.1	
High Temperature	4.5.2 & 4.5.3	
Altitude	4.6.1	
Decompression	4.6.2	
Overpressure	4.6.3	
Temperature Variation	5.3	Equipment tested to Category B
Humidity	6.0	Equipment tested to Category A
Shock	7.0	Equipment tested per DO-160B
Operational	7.2.1	
Crash Safety	7.3.1	
Vibration	8.0	Equipment tested without shockmounts to Categories M and N (Table 8-1)
Explosion	9.0	Equipment identified as Category X, no test required
Waterproofness	10.0	Equipment identified as Category X , no test required
Fluids Susceptibility	11.0	Equipment identified as Category X, no test required

Environmental Qualification (cont.)

Conditions	Section	Description of Conducted Tests
Sand and Dust	12.0	Equipment identified as Category X, no test required
Fungus	13.0	Equipment identified as Category X, no test required
Salt Spray	14.0	Equipment identified as Category X, no test required
Magnetic Effect	15.0	Equipment tested to Class A
Power Input	16.0	Equipment tested to Category B
Voltage Spike	17.0	Equipment tested to Category B
Audio Frequency Susceptibility	18.0	Equipment tested to Category B
Induced Signal Susceptibility	19.0	Equipment tested to Category B
Radio Frequency Susceptibility	20.0	Equipment tested to Category B
Radio Frequency Emissions	21.0	Equipment tested to Category B
Lightning Induced Transient Susceptibility	22.0	Equipment identified as Category X, no test required
Lightning Direct Effects	23.0	Equipment identified as Category X, no test required
Icing	24.0	Equipment identified as Category X, no test required