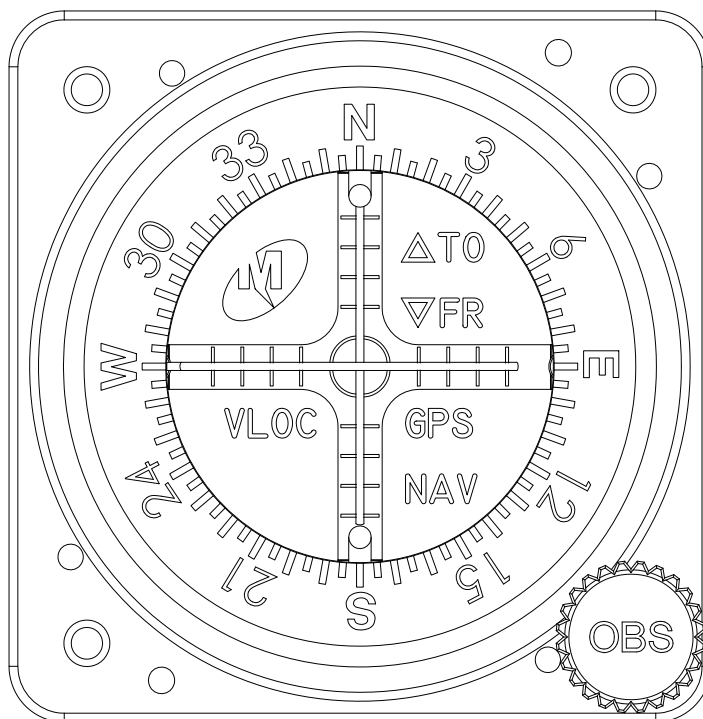




# INSTALLATION MANUAL AND OPERATING INSTRUCTIONS

## MD222-( ) SERIES TWO-INCH COURSE DEVIATION INDICATOR



Mid-Continent Instruments and Avionics  
9400 E. 34<sup>th</sup> Street N. Wichita, KS 67226 USA  
Phone 316-630-0101 • Fax 316-630-0723

Manual Number 9016311  
REV. D Aug. 7, 2007

<b>ECO</b>	<b>Rev.</b>	<b>Date</b>	<b>Detail</b>
	A		Initial Release.
	B	8/18/06	Glideslope and Nav warning indication method changed. Annunciators were added. Connector pin-out and outline drawings were revised.
4840	C	5/11/07	Update the DO-160 Qualification Form in the Appendix. Revise equipment limitation section 1.2.5. Change model number to MD222-().
4891	D	8/7/07	Added input voltage range notes to sections 1.2.3.2, 1.2.3.3, 1.25 and 3.4.

# TABLE OF CONTENTS

<b>SECTION 1</b>	<b>GENERAL DESCRIPTION</b>
1.1	INTRODUCTION
1.2	TECHNICAL SPECIFICATIONS
1.2.1	PHYSICAL CHARACTERISTICS
1.2.2	ENVIRONMENTAL CHARACTERISTICS
1.2.3	ELECTRICAL CHARACTERISTICS
1.2.4	INTERFACE
1.2.5	EQUIPMENT LIMITATIONS
1.2.6	MAJOR COMPONENTS
<b>SECTION 2</b>	<b>INSTALLATION CONSIDERATIONS</b>
2.1	COOLING
2.2	EQUIPMENT LOCATION
2.3	ROUTING OF CABLES
<b>SECTION 3</b>	<b>INSTALLATION PROCEDURE</b>
3.1	GENERAL INFORMATION
3.2	UNPACKING AND INSPECTING
3.3	MOUNTING THE MD222-( )
3.4	INSTALLATION LIMITATIONS
<b>SECTION 4</b>	<b>POST INSTALLATION CHECK</b>
4.1	PRE-INSTALLATION TESTS
4.2	DIMMING ADJUSTMENT
4.3	OPERATING INSTRUCTIONS
4.3.1	VOR OPERATION
4.3.2	LOCALIZER OPERATION
4.2.3	GLIDESLOPE OPERATION
<b>SECTION 5</b>	<b>INSTRUCTIONS FOR CONTINUED AIRWORTHINESS</b>
<b>FIGURE NO.</b>	<b>LIST OF ILLUSTRATIONS</b>
3-1	MATING CONNECTOR
3-2	MD222-( ) WIRING DIAGRAMS
3-3	CUTOUT DIMENSIONS FOR PANEL MOUNTING
3-4	MD222-( ) OUTLINE DRAWINGS
<b>APPENDIX</b>	<b>ENVIRONMENTAL QUALIFICATION FORM</b>

# SECTION 1 GENERAL DESCRIPTION

## 1.1 INTRODUCTION

The Mid-Continent Instruments and Avionics MD222-( ) two-inch Course Deviation Indicators (CDI) are designed to operate with VHF and GPS navigational equipment to provide OMNI (VOR), GPS, LOCALIZER (LOC), and Glideslope (GS) information.

The MD222-402 and 502 are designed to accept DC Left-Right, To-From and Nav valid signals from a GPS receiver or remote mounted VOR converter. Additionally, the MD222-406 and 506 will accept DC signals from a glideslope or VNAV converter that will drive the UP-DOWN needle along with accepting a vertical deviation valid signal. The MD222-402 and 406 incorporate NAV, GPS and VLOC annunciations. The MD222-502 and -506 incorporate NAV, GPS, and BC annunciations.

When GPS is selected for display, the MD222-( ) receives inputs from compatible GPS/navigation receivers or Flight Management Systems to provide a visual presentation to the pilot. All information presented on the navigation indicator is generated from this external receiver.

True synchro course resolver is ORZ zeroed to industry standard 300 degrees. All units are compatible with 5, 14 or 28 volt lighting systems.

**NOTE: The MD222-( ) does not contain NAV or Glideslope warning flags. During an invalid signal condition, the appropriate vertical or horizontal meter pointer will stow to an out-of-view position.**

## 1.2 TECHNICAL SPECIFICATIONS

### 1.2.1 PHYSICAL CHARACTERISTICS

Width:	2.4 Inches max
Height:	2.4 Inches max
Depth:	3.4 Inches max
Weight:	0.6 lbs.
Mounting:	Panel

### 1.2.2 ENVIRONMENTAL CHARACTERISTICS

TSO Compliance:	TSO C34e, C36e, C40c
Applicable Documents:	RTCA DO-160E, DO-192, DO-195, DO-196
Environmental Category:	F1S2AER(BB1G)XXXXXXXXZAAZ[ZC][WR]M[A3C3X]XXAX
Operating Temperature Range:	-20°C to +70°C
Humidity:	95% Non-Condensing
Altitude Range:	0 to 55,000 ft.

## 1.2.3 ELECTRICAL CHARACTERISTICS

### 1.2.3.1 POWER

OPERATING VOLTAGE: 10-32 VDC  
OPERATING CURRENT: 0.30 Amps

### 1.2.3.2 VOR/LOC/GPS

OBS RESOLVER: Electrical zero: 300 degrees, ORZ

DEVIATION: Input impedance: 1K ohms  $\pm 10\%$ .  
Deflection sensitivity:  
150mV  $\pm 10\%$  for full-scale  
deflection  
Input range (common  
mode/reference): 1.0 to 5.0 volts

VALID SIGNAL: Input impedance: 1K ohms  $\pm 10\%$   
Pointer out of view:  
<125mV  $\pm 10\%$   
Pointer in view:  
260mV  $\pm 10\%$  max  
Input range (common  
mode/reference): 0 to 5.0 volts

TO/FROM LED INDICATOR: Impedance: 200 ohms  $\pm 10\%$   
Indication:  $\pm 40\text{mV} \pm 15\%$   
Input range (common  
mode/reference): 0 to 5.0 volts

### 1.2.3.3 GLIDESLOPE: (MD222-406 and 506 only)

DEVIATION: Input Impedance: 1K ohms  $\pm 10\%$   
Deflection sensitivity:  
150mV  $\pm 10\%$  for full-scale  
deflection  
Input range (common  
mode/reference): 1.0 to 5.0 volts

VALID SIGNAL: Input Impedance: 1K ohms  $\pm 10\%$   
Pointer out of view:  
<125mV  $\pm 10\%$   
Pointer in view:  
260mV  $\pm 10\%$  max  
Input range (common  
mode/reference): 0 to 5.0 volts

### 1.2.4 INTERFACE:

NAV/LOC/GPS: Displays valid lateral deviation  
with signal inputs and TO/FROM  
information from the GPS/NAV  
receiver.

GLIDESLOPE: Displays valid GS up-down  
information from the glideslope  
receiver.

OBS KNOB: Used to select appropriate  
inbound or outbound bearing to a  
VOR station or GPS waypoint.

MISCELLANEOUS: Provides OBS resolver  
information to a GPS/NAV  
receiver. Provides annunciation of  
NAV, VLOC, BC (if applicable)  
and GPS selections.

## 1.2.5 EQUIPMENT LIMITATIONS

### REQUIREMENTS FOR VOR/ILS SYSTEM:

1. The navigation receiver shall be certified to the standards of TSO C40a/b/c or TSO C36c/d/e.

### REQUIREMENTS FOR GLIDESLOPE SYSTEM:

1. The glideslope receiver/converter shall be certified to the standards of TSO C34c/d/e.
2. The centering error as presented to the pilot shall not exceed 13% of standard deflection with a 95% probability under all combinations of the service conditions listed in RTCA document DO-192.
3. Deviation current with a 700 $\mu$ V standard glideslope deviation signal applied to the receiver input shall be 78 $\mu$ A  $\pm$ 10% into a 1000 ohm load. Deviation current shall not change more than 15% as the RF level of a standard glideslope deviation signal is varied from 100 to 10,000 $\mu$ A. Deviation current shall be proportional within 5% to the difference in depth of modulation of the 90Hz and 150Hz tones.
4. Warning signal output shall be a DC current less than 125 $\mu$ A into a 1000-ohm load for a warning indication. Warning signal for a fully negated warning shall be a DC current of 260 $\mu$ A minimum into a 1000-ohm load.

Note the MD222 input voltage range limitations in sections 1.2.3.2 and 1.2.3.3 above and verify that connected navigation equipment's outputs are within those ranges.

## 1.2.6 MAJOR COMPONENTS

This indicating system is comprised of one major component, the MD222-( ) Course Deviation Indicator.

## **SECTION 2 INSTALLATION CONSIDERATIONS**

### **2.1 COOLING**

No direct cooling is required. As with any electronic equipment, overall reliability may be increased if the MD222-( ) is not located near any high heat source or crowded next to other equipment.

### **2.2 EQUIPMENT LOCATION**

The MD222-( ) course deviation indicator must be mounted as close to the pilot's field of view as possible. Since this is a panel-mounted instrument, the unit depth, with connector attached, must also be taken into consideration.

### **2.3 ROUTING OF CABLES**

Care must be taken not to bundle the MD222-( ) logic and low-level signal lines with any high-energy sources. Examples of these sources include 400 HZ AC, Comm., DME, HF and transponder transmitter coaxial cables. Always use shielded wire as shown on the installation print. Avoid sharp bends in cabling. Avoid routing near aircraft control cables.

## **SECTION 3 INSTALLATION PROCEDURES**

### **3.1 GENERAL INFORMATION**

This section contains interconnect diagrams, mounting dimensions and other information pertaining to the installation of the MD222-( ). After installation of cabling and before installation of the equipment, ensure that power is applied only to the pins specified in the interconnect diagram.

### **3.2 UNPACKING AND INSPECTING EQUIPMENT**

When unpacking equipment, make a visual inspection for evidence of damage incurred during shipment. The following parts should be included:

1. MD222-( ) Series course Deviation Indicator
2. Connector Kit (25 pin): MCI P/N 7014517
3. Installation Manual: MCI P/N 9016311

### **3.3 MOUNTING THE MD222-( ) INDICATOR**

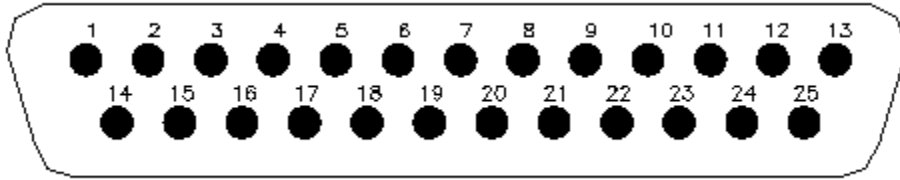
The MD222-( ) course deviation indicator should be mounted as close to the pilot's field of view as possible. Avoid mounting close to heater vents or other high heat sources. Allow a clearance of at least 3 inches from the back of unit for connector removal.

The MD222-( ) is to be secured in place behind the panel since it is designed for rear mount only. Make a panel cutout as shown in Figure 3.3. Secure the indicator in place with three 6-32 x 1.0" (max) flat head Phillips screws.

### **3.4 INSTALLATION LIMITATIONS**

Wire the aircraft harness according to the appropriate figure. Use 24 AWG or larger wire for all connections. You **MUST** use shielded wire where shown by the radio manufacturer. Avoid sharp bends and routing cable near high-energy sources. Care must be taken to tie the harness away from aircraft controls and cables.

Note the MD222-( ) input voltage range limitations in sections 1.2.3.2 and 1.2.3.3 above and verify that connected navigation equipment's outputs are within those ranges.

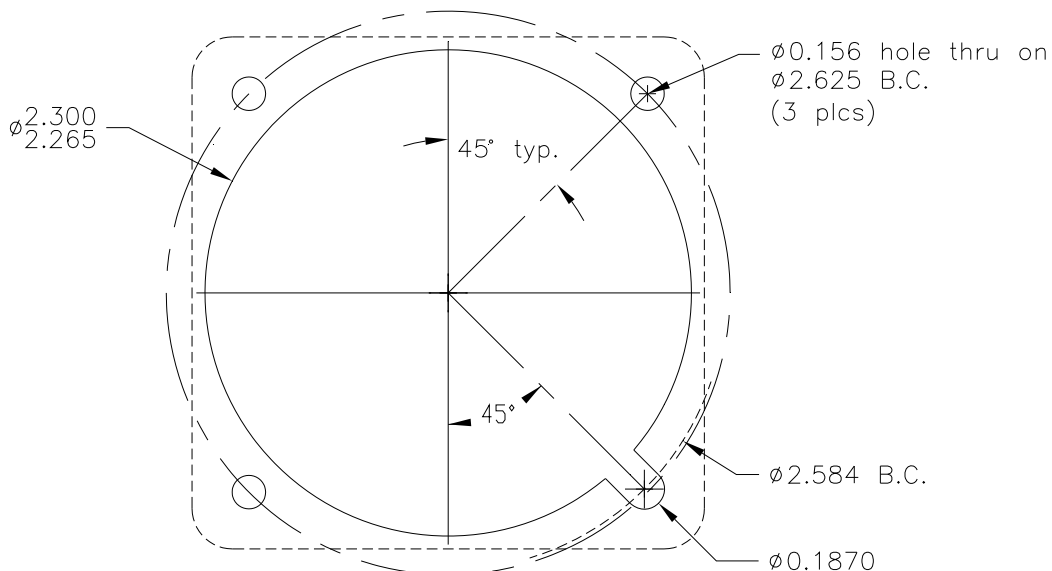


**FIGURE 3-1 REAR VIEW OF MATING CONNECTOR**

Connector Pin Out			
Pin #		Pin #	
1	OBS Rotor H	14	NAV Annunciation
2	OBS Rotor C	15	GPS Annunciation
3	OBS Stator D	16	+To
4	OBS Stator G	17	+From
5	OBS Stator E	18	+GS Warning*
6	OBS Stator F	19	-GS Warning*
7	Reserved	20	+NAV Warning
8	VLOC (or BC) Annunciation	21	-NAV Warning
9	+5 VDC Lighting	22	+Left
10	+14 VDC Lighting	23	+RT
11	+28 VDC Lighting	24	+Down*
12	10-32 Vdc Power	25	+Up*
13	Power/Lighting Ground		

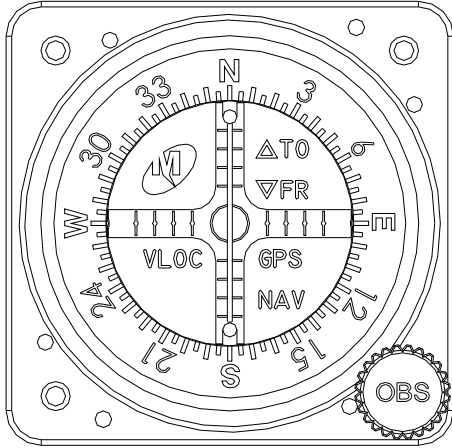
\* Applicable on MD222-406/506 only

**FIGURE 3-2 WIRING DIAGRAM, MD222-( )**

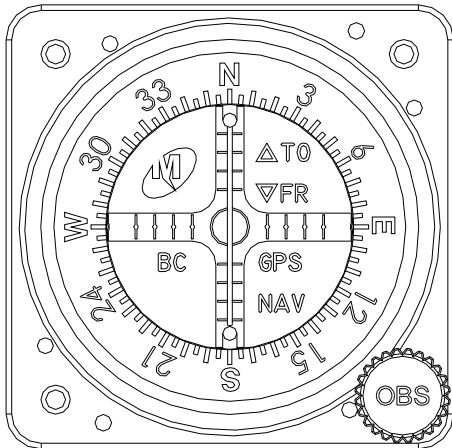
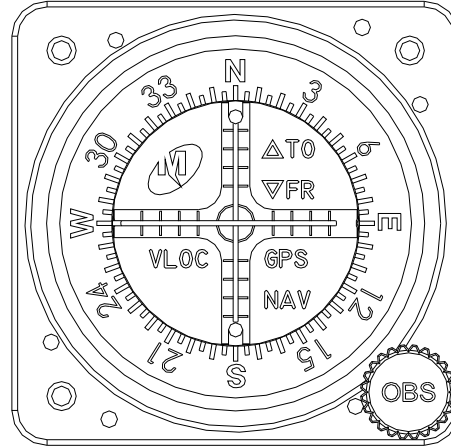


**FIGURE 3-3 CUTOUT DIMENSIONS FOR PANEL MOUNTING**

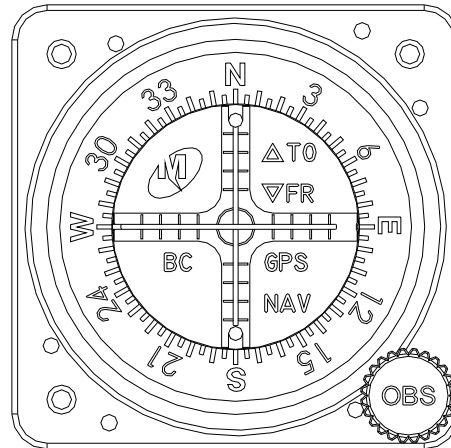
MD222-402



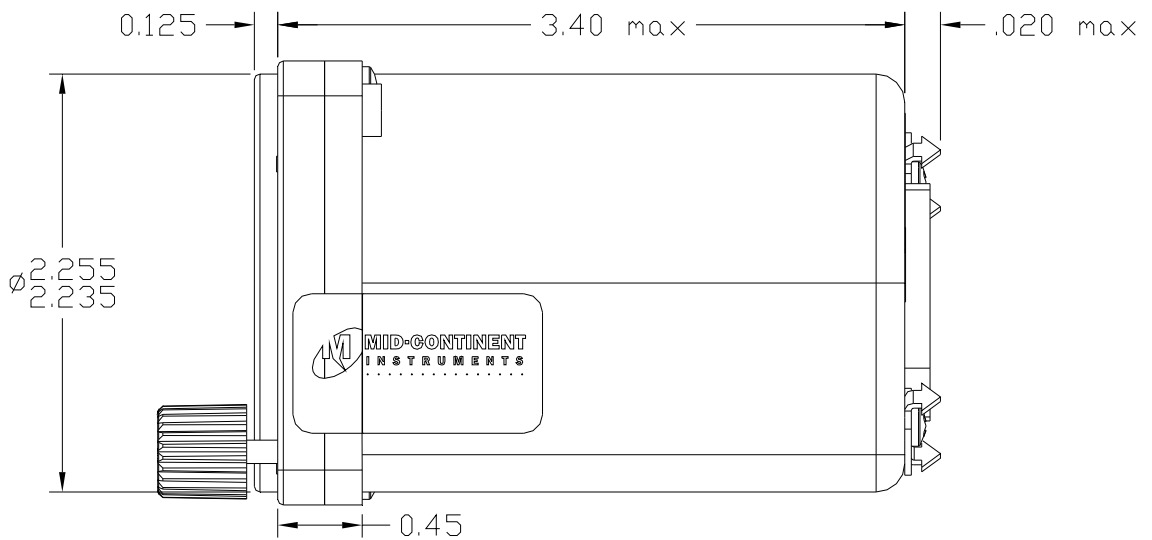
MD222-406



MD222-502



MD222-506



**FIGURE 3-4 OUTLINE DRAWINGS**

## **SECTION 4 POST INSTALLATION CHECK**

### **4.1 PRE-INSTALLATION TESTS**

With the MD222-( ) indicator disconnected, turn on the avionics master switch and verify that aircraft power on connector pin 12 is 14 VDC or 28 VDC. Using an ohmmeter, verify pin 13 is aircraft ground.

### **4.2 DIMMING ADJUSTMENT**

During installation of the MD222-( ) course deviation indicator, check the brightness of the GPS, NAV, BC (if applicable) and VLOC annunciations as well as the compass ring. The ambient and aircraft panel lighting levels should be set to simulate minimum light operations and the annunciators should be useable and consistent with other cockpit lighting. If required, the dimming adjustment is located on the back of the MD222-( ) unit and is labeled "DIM ADJ".

### **4.3 OPERATING INSTRUCTIONS**

All controls required to operate the MD222-( ) course deviation indicator are located on the front of the unit and on the front panel of the related navigation receiver.

#### **4.3.1 VOR OPERATION**

Channel the NAV receiver to the desired VOR frequency and positively identify the station by listening to received audio. This signal is valid if the vertical pointer is in view.

Flying inbound to a VOR station is accomplished by first rotating the OBS knob to center the deviation indicator. Next, determine that the TO condition is illuminated on the TO-FROM indication. The aircraft is then turned to a magnetic heading, which is the same as the selected course with proper allowance for wind correction. When the aircraft is on course, the vertical pointer will be centered. If the aircraft moves off course, the deviation indicator will move away from the center position and flying in the direction of pointer deflection (left or right) is required to re-intercept the course.

The procedure for flying outbound from a VOR station is the same as flying inbound, except the OBS knob is first rotated to cause a "FROM" indication to appear with the pointer centered.

To intercept a selected VOR radial (from the station) and fly outbound, turn the OBS control to set the desired radial under the top indicator index. Maneuver the aircraft to fly the selected radial magnetic heading plus 45° intercept angle that will provide a sufficient intercept angle. The intercept angle should be reduced as the deviation needle approaches an on course condition (center) to prevent excessive course bracketing.

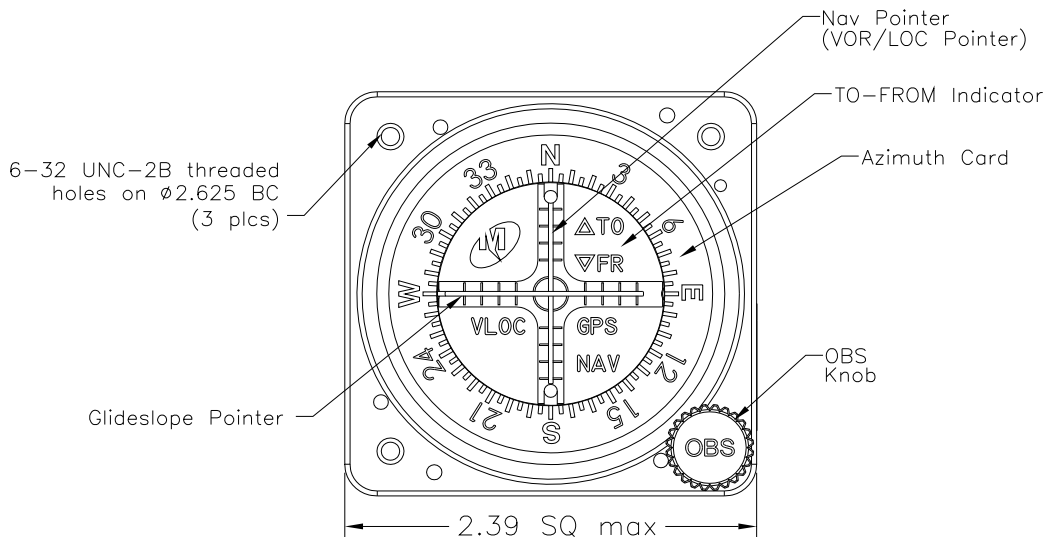
### 4.3.2 LOCALIZER OPERATION

Select the desired localizer frequency and observe that the vertical pointer is in view indicating a valid condition. The TO-FROM indication is not functional for localizer operation. When flying on the front course, or outbound on the back course, make corrections toward the localizer (vertical) needle deflection. The localizer path narrows as the approach end of the runway becomes closer. When flying inbound on the back course or outbound on the front course, the corrections are made away from the direction of needle deflection. A helpful hint when flying the localizer is to set the localizer heading on the OBS dial under the lubber line for quick reference.

### 4.3.3 GLIDESLOPE OPERATION

The glideslope (horizontal) needle provides the pilot with vertical steering information during ILS approaches. The glideslope circuitry is energized when the associated localizer frequency is selected on the navigation receiver. Observe that the horizontal pointer is in view. The glideslope needle deflects towards the direction the pilot must fly to remain on the glide path.

If the glideslope needle deflects upward, the aircraft is below the glide path and the pilot must climb to again intercept the glide path and center the needle. If the needle deflects downward the aircraft is above the glide path and the pilot must descend to again intercept the glide path and center the needle. When the needle is centered the aircraft is on the glide path.



## SECTION 5 INSTRUCTIONS FOR CONTINUED AIRWORTHINESS

Mid-Continent Instruments and Avionics products are designed and manufactured to allow “*on condition maintenance*”, defined as no maintenance required until equipment does not properly perform its intended function. If service is required, Mid-Continent Instruments and Avionics should complete a performance test.

**ENVIRONMENTAL QUALIFICATION FORM**  
**RTCA / DO160E**

NOMENCLATURE: MD222-( ) COURSE DEVIATION INDICATOR

MODEL NO: MD222-( ) TSO NO: C34e, C36e, C40c

MANUFACTURER TEST SPECIFICATION: TS240

MANUFACTURER: Mid-Continent Instruments and Avionics

9400 E 34 Street N

Wichita, KS 67226

PHONE (316) 630-0101

<b>Conditions</b>	<b>Section</b>	<b>Description of Tests</b>
Temperature and Altitude	4.0	Equipment tested to Categories F1
Survival Low Temperature	4.5.2	Survival Low Temp=-55°C
Operating Low Temperature	4.5.2	Operating Low Temp=-20°C
Temperature Variation	5.3	Equipment tested to Category S2
Humidity	6.0	Equipment tested to Category A
Operational Shocks and Crash Safety	7.0	Equipment tested to Category E (Type 5, Fixed-Wing and Helicopter)
Vibration	8.0	Equipment tested w/o shock mounts to Category R, curves B, B1, G
Explosion	9.0	Equipment identified as Cat. X, no test required
Waterproofness	10.0	Equipment identified as Cat. X, no test required
Fluids Susceptibility	11.0	Equipment identified as Cat. X, no test required
Sand and Dust	12.0	Equipment identified as Cat. X, no test required
Fungus	13.0	Equipment identified as Cat. X, no test required
Magnetic Effect	15.0	Equipment tested to Category Z
Power Input	16.0	Equipment tested to Category A
Voltage Spike	17.0	Equipment tested to Category A
Audio Frequency Susceptibility	18.0	Equipment tested to Category Z
Induced Signal Susceptibility	19.0	Equipment tested to Category ZC
Radio Frequency Susceptibility	20.0	Tested for conducted susceptibility to Category W Tested for radiated susceptibility to Category R
Radio Frequency Emissions	21.0	Equipment tested to Category M
Lightning Induced Transient Susceptibility	22.0	Equipment tested to Pin Test: Waveform A, Level 3 Cable Bundle: Waveform C Single/Multiple Stroke Level 3 Multiple Burst no test performed (X) [A3C3X]
Lightning Direct Effects	23.0	Equipment identified as Cat. X, no test required
Icing	24.0	Equipment identified as Cat. X, no test required
Electrostatic Discharge (ESD)	25.0	Equipment tested to Category A
Fire, Flammability	26.0	Equipment identified as Cat. X, no test required