



INSTALLATION MANUAL AND OPERATING INSTRUCTIONS

MD41-1200D Series Terrain Awareness Annunciation Control Unit for Honeywell KGP 560 EGPWS Systems

Designed for Dual MD41 Installations

MD41-1208D	28vdc	Horizontal Mount
MD41-1218D	28vdc	Vertical Mount (shown on page 10)
MD41-1204D	14vdc	Horizontal Mount
MD41-1214D	14vdc	Vertical Mount (shown on page 10)

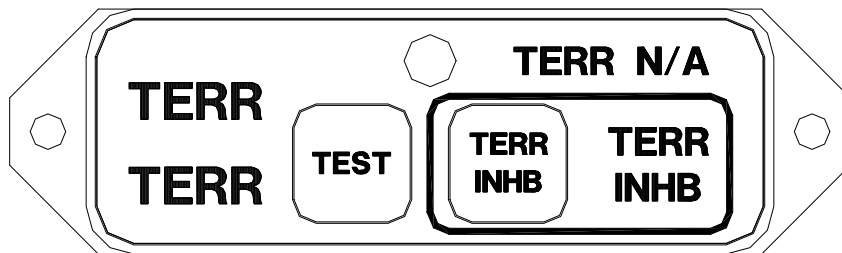

Mid-Continent Instruments and Avionics
9400 E. 34th Street N., Wichita, KS 67226 USA
Phone 316-630-0101 • Fax 316-630-0723

Manual Number 9016029
REV. B March, 31, 2005

Revision Detail

Rev.	Date	Detail
A	07-28-04	Complete issue
B	03-31-05	Changed 1.2.4.1 from momentary to alternate action. Added statement: "The Terrain Inhibit switch may be in the <i>out</i> or <i>in</i> position for Terrain Inhibit to occur. This in normal. "

TABLE OF CONTENTS

SECTION 1	GENERAL DESCRIPTION
1.1	INTRODUCTION
1.2	SPECIFICATIONS, TECHNICAL
1.2.1	PHYSICAL CHARACTERISTICS
1.2.2	ENVIRONMENTAL CHARACTERISTICS
1.2.3	SPECIFICATIONS, ELECTRICAL
1.2.4	FRONT PANEL CONTROLS AND ANNUNCIATIONS
1.2.4.1	CONTROLS
1.2.4.2	ANNUNCIATIONS
1.2.5	EQUIPMENT LIMITATIONS
1.2.6	MAJOR COMPONENTS
SECTION 2	INSTALLATION CONSIDERATIONS
2.1	COOLING
2.2	EQUIPMENT LOCATION
2.3	ROUTING OF CABLES
SECTION 3	INSTALLATION PROCEDURE
3.1	GENERAL INFORMATION
3.2	UNPACKING AND INSPECTING
3.3	MOUNTING THE MD41-()
3.4	INSTALLATION LIMITATIONS
SECTION 4	POST INSTALLATION CHECKOUT
4.1	PRE-INSTALLATION TEST
4.2	OPERATING INSTRUCTIONS
4.3	AIRWORTHINESS STATEMENT
SECTION 5 INSTRUCTIONS FOR CONTINUED AIRWORTHINESS	
FIGURE NO.	LIST OF ILLUSTRATIONS
3.1	SCHEMATIC PINOUT, 25 PIN DSUB
3.2	OUTLINE DRAWING
3.3	WIRING DIAGRAM, MD41-1208D, -1208D(5V)
3.4	SCHEMATIC DIAGRAM, MD41-1208D, -1218D

APPENDIX

ENVIRONMENTAL QUALIFICATION FORM

SECTION 1 GENERAL DESCRIPTION

1.1 INTRODUCTION

The MD41-1204D, -1214D, -1208D and -1218D is a compact, self-contained Annunciation and Control Unit (ACU). This ACU series was designed to allow installations of dual MD41's with the Honeywell KGP 560 system. Unique interlocking between these two units allows the pilot or copilot to select Terrain Inhibit, which results in both MD41's simultaneously displaying this selection and also controlling the KGP 560.* Additionally, this fully integrated, control unit provides annunciation and mode selection required for FAA approval.

Other features include dual 100,000 hour LED's used for all annunciations, internally lighted selection switches and choice of manual or automatic photocell dimming. An external annunciation dimming adjustment is provided for balancing low-level light conditions.

*The Terrain Inhibit switch may be in the *out* or *in* position for Terrain Inhibit to occur. This is normal.

1.2 SPECIFICATIONS, TECHNICAL

1.2.1 PHYSICAL CHARACTERISTICS

Mounting:	Panel
Width:	2.75 Inches
Height:	.80 Inches
Depth:	3.22 Inches
Weight:	0.50 lbs.

1.2.2 ENVIRONMENTAL CHARACTERISTICS

TSO Compliance:	C151a
PMA Compliance	PQ3738CE
Applicable Documents:	RTCA DO-160D
Operating Temperature Range:	-55°C to +70°C
Humidity:	95% Non-Condensing
Altitude Range:	0 to 55,000 ft.
Operational Shock:	Rigid Mounting, 6 G Operational 20 G Crash Safety

1.2.3 SPECIFICATIONS, ELECTRICAL

Design	All Solid State
MD41-1204D, -1214D	0.30 Amps
MD41-1208D, -1218D	0.40 Amps
MD41-1208D(5V), -1218D(5V)	0.42 Amps

1.2.4 FRONT PANEL CONTROLS AND ANNUNCIATIONS

1.2.4.1 CONTROLS

TEST	Momentary switch, when pressed, will activate the TAWS computer self-test.
TERR/INHB	Alternate action switch, when pressed, will place TAWS/EGPWS computer in standby mode.*

* The Terrain Inhibit switch may be in the *out* or *in* position for Terrain Inhibit to occur. This in normal

1.2.4.2 ANNUNCIATIONS

TERR/NA (amber)	Terrain information is not available.
TERR (amber)	Terrain is very near or above the aircraft altitude.
TERR (red)	Terrain is well above aircraft altitude.
TERR/ INHB (white)	TWAS/EGPWS system has been placed in standby mode.

1.2.5 EQUIPMENT LIMITATIONS

The MD41-12XXD series is designed for installation as pairs only.

The MD41-12XXD series control units contain specific dash numbers to be used with various Terrain Awareness Warning Systems. The installer must match the correct controller part number with the system being installed.

The MD41-1204D, -1214D, -1208D, -1218D, -1208D(5V), -1218D(5V) is TSO'D and certified for use with the Honeywell KGP 560 EGPWS systems. Any attempts to install the listed units in an installation other than above systems is prohibited. **This will void the TSO.**

NOTE: If the MD41-() is disconnected or removed from the aircraft, there will be no effect in the operation of the EGPWS system.

1.2.6 MAJOR COMPONENTS

This system is comprised of two major components, the MD41-12XXD series TAWS Annunciation Control Units.

SECTION 2 INSTALLATION CONSIDERATIONS

2.1 COOLING

No direct cooling is required. As with any electronic equipment, overall reliability may be increased if the MD41-1204D, -1214D, -1208D, -1218D is not located near any high heat source or crowded next to other equipment. Means of providing a gentle airflow will be a plus.

2.2 EQUIPMENT LOCATION

The MD41-12XXD must be mounted as close to the pilot's field of view as possible. Please reference the EGPWS installation manual for approved locations. The unit depth, with connector attached, must also be taken into consideration.

2.3 ROUTING OF CABLES

Care must be taken not to bundle the MD41-1204D, -1214D, -1208D, -1218D logic and low level signal lines with any high energy sources. Examples of these sources include 400 HZ AC, Comm, DME, HF and transponder transmitter coax. Always use shielded wire when shown on the installation print. Avoid sharp bends in cabling and routing near aircraft control cables.

SECTION 3 INSTALLATION PROCEDURES

3.1 GENERAL INFORMATION

This section contains interconnect diagrams, mounting dimensions and other information pertaining to the installation of the MD41-1204D, -1214D, -1208D, -1218D. After installation of cabling and before installation of the equipment, ensure that power is applied only to the pins specified in the interconnect diagram.

3.2 UNPACKING AND INSPECTING EQUIPMENT

When unpacking equipment, make a visual inspection for evidence of damage incurred during shipment. The following parts should be included:

1. MD41-1204D (14V) or MD41-1208D (28V) Horiz. Mount
MD41-1214D (14V) or MD41-1218D (28V) Vert. Mount
MD41-1208D(5V), (28volt) 5 volt button lighting Horiz. Mount
MD41-1218D(5V), (28volt) 5 volt button lighting Vert. Mount
2. J1 Connector Kit (25 pin). MCI P/N 7014517
3. Installation Manual. MCI P/N 9016029

3.3 MOUNTING THE MD41-()

Avoid mounting close to heater vents or other high heat sources. Allow a clearance of at least 3 inches from back of unit for plug removal.

The indicator is secured in place behind the panel since it is designed for rear mount only. Make a panel cutout as shown in Figure 3-2. Secure the indicator in place with two 4-40 x 3/8 flat head phillips screws.

3.4 INSTALLATION LIMITATIONS

Wire the aircraft harness according to figure 3-3 or 3-4. Use at least 24 AWG wire for all connections. Avoid sharp bends and routing cable near high-energy sources. Care must be taken to tie the harness away from aircraft controls and cables. Also see equipment limitations, section 1.2.5.

“The TSO identifies the minimum performance standards, tests and other conditions applicable for issuance of design and production approval of the article. The TSO does not specifically identify acceptable conditions for installations of the article. The TSO applicant is responsible for documenting all limitations and conditions suitable for installation of the article. An applicant requesting approval for installation of the article within a specific type or class of product is responsible for determining environmental and functional compatibility.”

This Annunciation Control Unit is part of a incomplete system. The intended function is to provide required or optional annunciation and mode selection for Class A, B or C TAWS systems.

J1 CONNECTOR

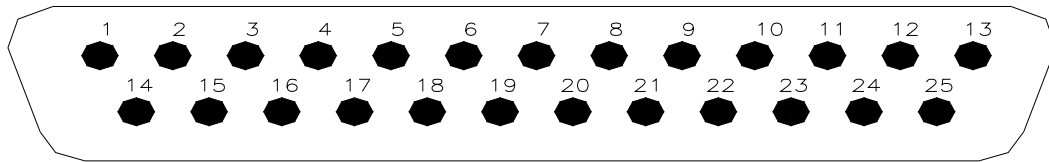

REAR VIEW OF J1 CONNECTOR

J1

PIN NO.

1 -----	Terrain Inhibit select output
2 -----	Terrain Inhibit annunciate output
3 -----	Terrain Inhibit annunciate output
4 -----	Terrain Inhibit strap
5 -----	Terrain Caution annunciate input. Receives logic low to annunciate.
6 -----	LAMP TEST (receives ground from remote test switch)(optional conn).
7 -----	Bright/Dim annunciation lamp power..
8 -----	Push Button Lighting. To lighting buss.
9 -----	Ground for push-button lighting.
10 -----	Terrain N/A annunciate input. Receives logic low to annunciate.
11 -----	Terrain Warning annunciate input. Receives logic low to annunciate.
12 -----	Internal photocell dimming output. To use, jumper pin 12 to pin 7.
13 -----	Unit power.
14 -----	Terrain Inhibit interlock #2
15 -----	Terrain Inhibit interlock #1
16 -----	Spare
17 -----	Spare
18 -----	spare
19 -----	Terrain Self-Test output
20 -----	Terrain Inhibit annunciate input
21 -----	Power Ground
22 -----	Shield Ground
23 -----	Shield Ground
24 -----	Shield Ground
25 -----	Terrain Inhibit strap ground

FIGURE 3-1 SCHEMATIC PINOUT, 25 PIN DSUB

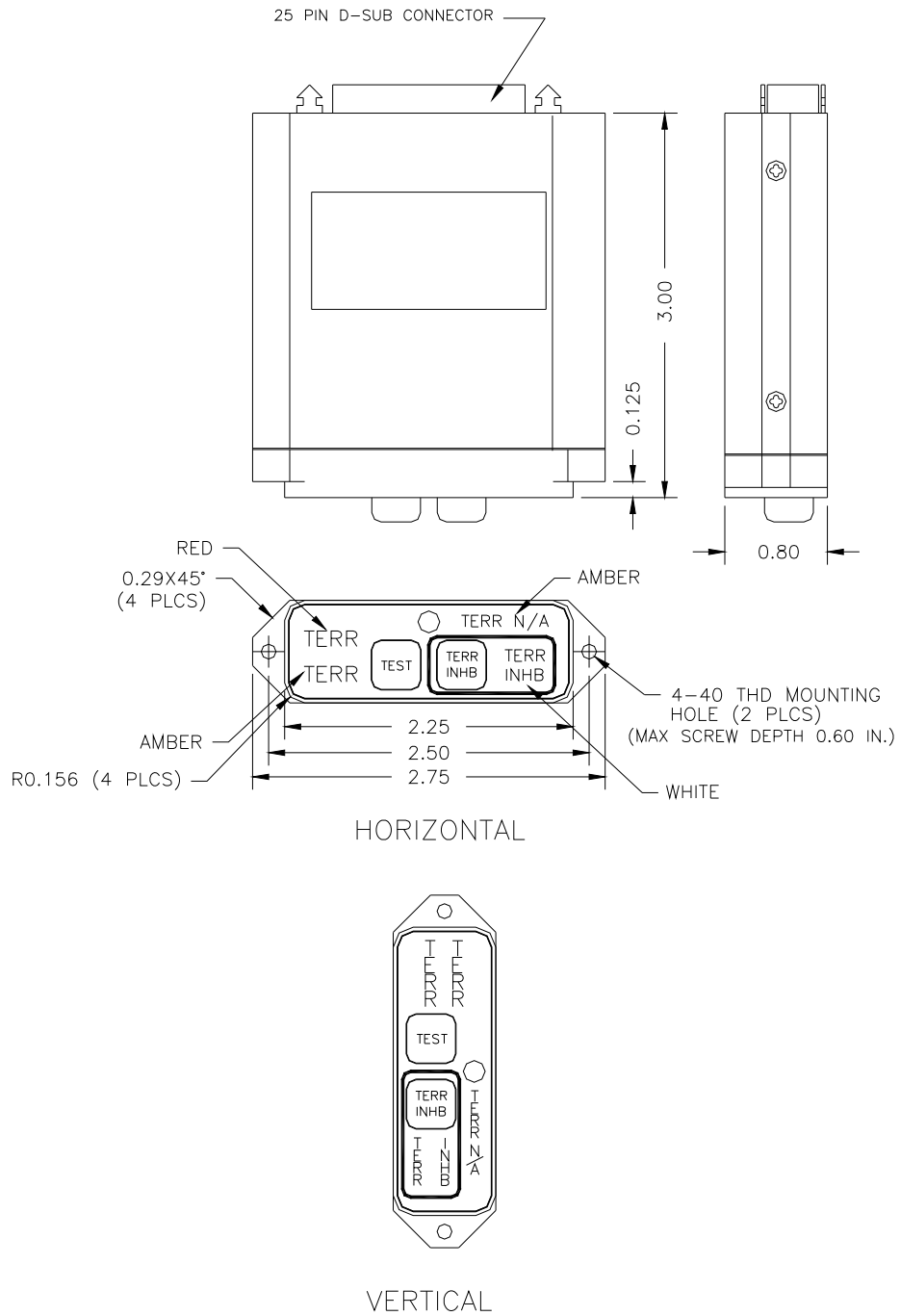

Note 1: Use two 4-40 X 3/8" Flat Head Phillips Screws for Mounting

FIGURE 3-2 OUTLINE DRAWING

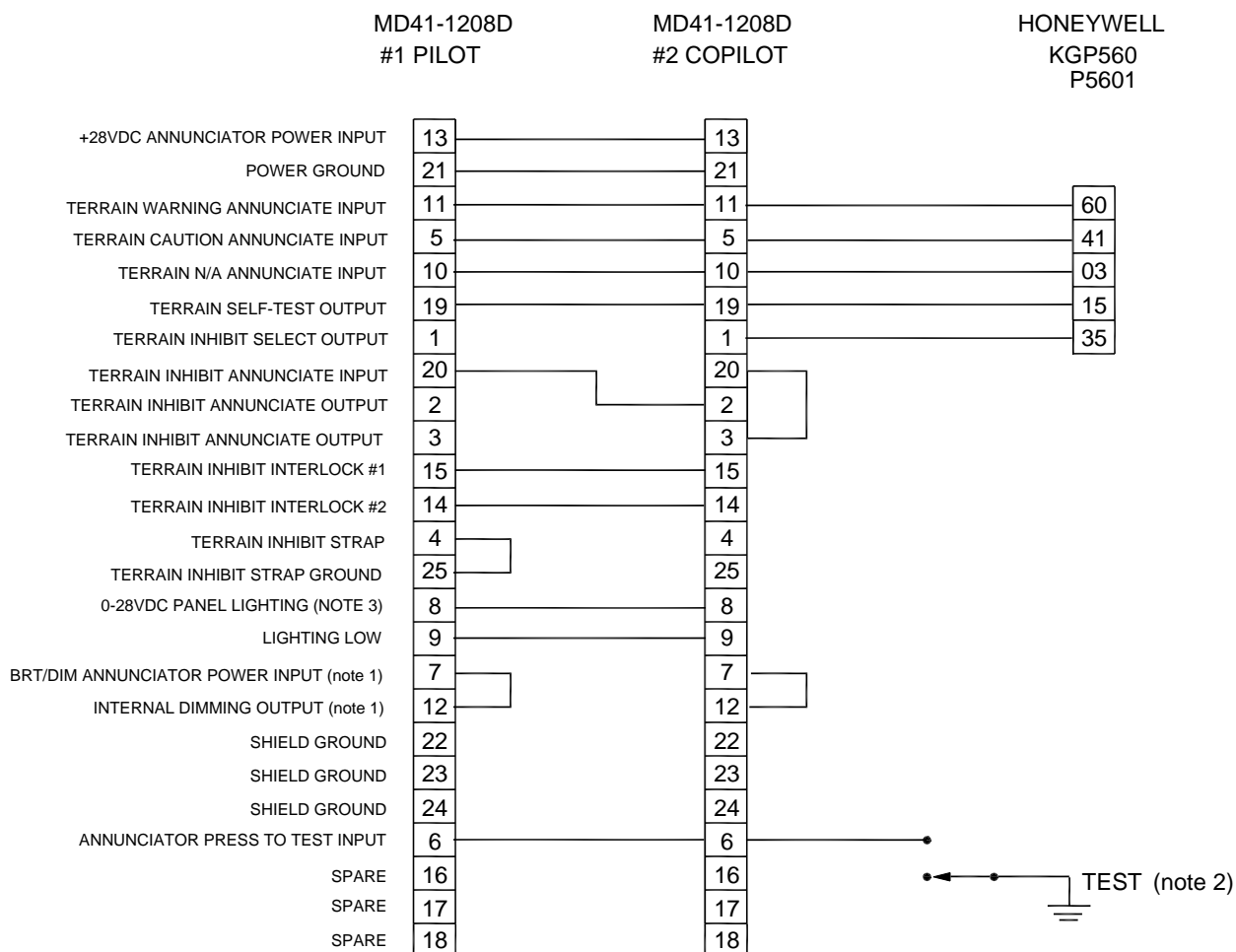

NOTES:

- 1) JUMPER 7 TO 12 FOR ANNUNCIATION BRIGHTNESS TO BE CONTROLLED BY INTERNAL PHOTOCELL.
- 2) MOMENTARY SWITCH FOR ANNUNCIATION LAMP TEST. (optional connection)
- 3) 5 VOLT FOR MD41-1208D(5V), -1218D(5V)
- 4) REFER TO HONEYWELL KGP 560 INSTALLATION MANUAL FOR ACTUAL INSTALLATION.
- 5) REFER TO ACU SCHEMATIC IN THIS MANUAL FOR DETAILED CIRCUIT.

FIGURE 3-3 WIRING DIAGRAM MD41-1208D, -1208D(5V)

Revisions		Date	Approved
ECO	Rev. Description	7/21/04	DDT/BAW
A	Initial release.		

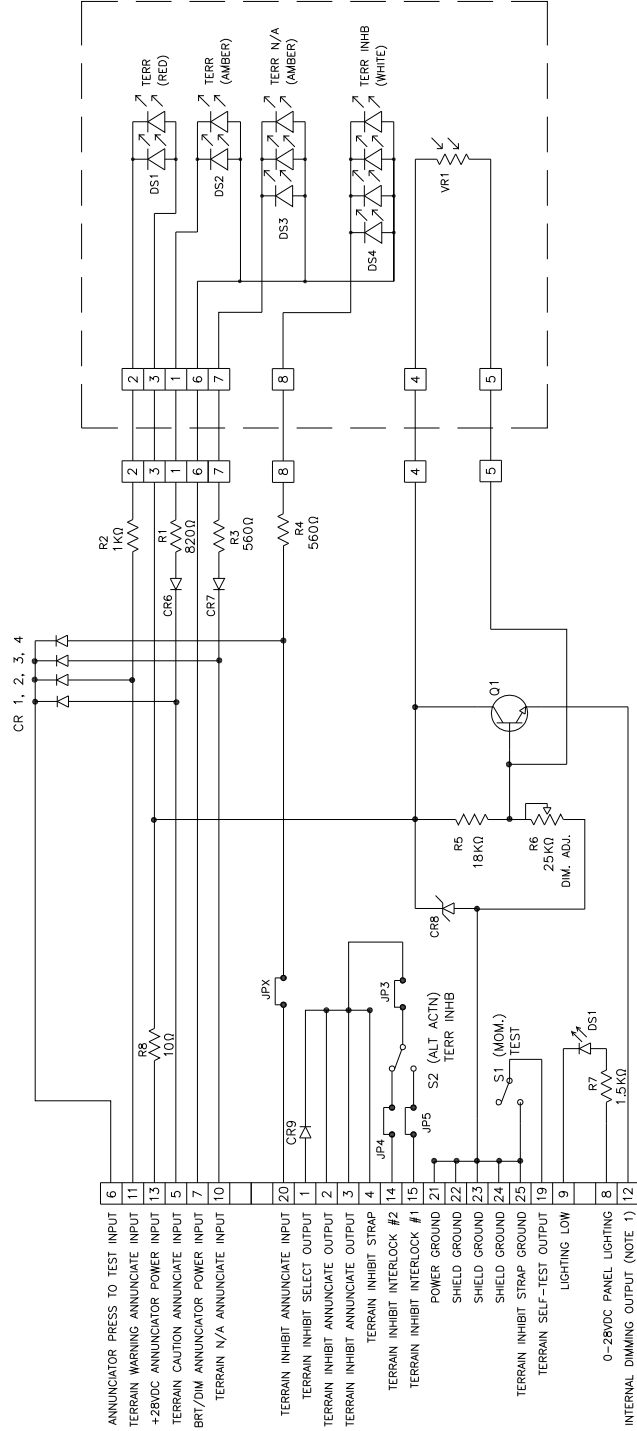

Note:

- 1) Jump the internal dimming output (Pin 12) to BRT/DIM input (Pin 7) to use internal dimming circuit, otherwise leave it open.
- 2) Unless otherwise specified, all resistors are 1/4W, 5%, all diodes are 1N4005.
- 3) JPX will be in place of CRS on PCB.

UNLESS OTHERWISE SPECIFIED, ALL DIMENSIONS ARE IN INCHES. TOLERANCE: FRACTIONAL= $\pm 1/64$ XX= ± 0.015 XXX= ± 0.002 ANGULAR= $\pm 0.05^\circ$ CONCENTRICITY: 0.005 TIR BREAK ALL SHARP EDGES THREADS PER MIL-S-7742	DRAWN: B Barnes 6/16/04	This document discloses proprietary information of Mid-Continent Instrument Co. It may be reproduced or disclosed only by the Mid-Continent Instrument Co. and is not to be used for any other purpose without the express written consent of Mid-Continent Instrument Co.	MID-CONTINENT INSTRUMENTS
APPROVED: BAW 7/22/04	TITLE: MD41-1208D SCHEMATIC	PART NUMBER: 9016024	
SCALE: None	DO NOT SCALE THIS DRAWING		SHEET 1 of 1

FIGURE 3-4 SCHEMATIC, MD41-1208D, -1218D

SECTION 4 POST INSTALLATION CHECKOUT

4.1 PRE INSTALLATION TESTS

With the MD41-() disconnected, turn on the avionics master switch and verify that aircraft power is on pin 13 for. Using an ohm-meter, verify pin 21 is aircraft ground.

4.2 OPERATING INSTRUCTIONS

Press the lamp test button (if installed), all annunciations should light. Continue pressing the lamp test button and cover the photocell window located in the center of the front panel. All annunciations should dim.

Annunciation brightness at the minimum dimming level may be adjusted by rotation of the dimmer control located on the bottom of the MD41-() case. CW rotation lowers the dimming level.

Refer to the appropriate EGPWS pilots guide or installation manual for final testing of the MD41-12XXD.

*The Terrain Inhibit switch may be in the *out* or *in* position for Terrain Inhibit to occur. This in normal.

SECTION 5: INSTRUCTIONS FOR CONTINUED AIRWORTHINESS

5.1 INTRODUCTION

This document identifies the instructions for Continued Airworthiness for the MD41-12XX series TAWS Annunciation Control Unit.

5.2 CONTROL, OPERATION INFORMATION

Refer to the Honeywell KGP 560 Avionics Pilots Guide and section 1.2.4 of this manual.

5.3 MAINTENANCE INSTRUCTIONS

Repair of the MD41-12XXD ACU is “on condition only”, periodic maintenance is not required.

Calibration and inspection intervals are not required. Service life will be a minimum of 20,000 hours.

5.4 TROUBLESHOOTING INFORMATION

Refer to the MD41-12XXD series Maintenance Manual.

5.5 REMOVAL AND REPLACEMENT INFORMATION

If the unit is removed and reinstalled, a functional check of the equipment should be conducted in accordance with Honeywell KGP 560 preflight test procedure.

5.6 DIAGRAMS

Refer to figure 3-2, 3-3 and 3-4 of this manual.

5.7 SPECIAL INSPECTION REQUIRMENTS: N/A

5.8 SPECIAL TOOLS: None

5.9 OVERHAUL PERIOD: No overhaul time limitations

ENVIRONMENTAL QUALIFICATION FORM
RTCA / DO160D

NOMENCLATURE: MD41-() TERRAIN AWARENESS ANNUNCIATION CONTROL
UNIT

MODEL NO: MD41-()

TSO C151a

MANUFACTURER: Mid-Continent Instruments and Avionics
9400 E. 34th Street N.
Wichita, KS 67226
Phone (316) 630-0101

Conditions	Section	Description of Conducted Tests
Temperature and Altitude	4.0	Equipment tested to Category A1 and F2 Cooling air not required Not Tested
Low Temperature	4.5.1	
High Temperature	4.5.2 & 4.5.3	
In-Flight Loss of Cooling	4.5.4	
Altitude	4.6.1	
Decompression	4.6.2	
Overpressure	4.6.3	
Temperature Variation	5.0	Equipment tested to Category C
Humidity	6.0	Equipment tested to Category A
Shock	7.0	Equipment tested to Category B
Operational	7.2	
Crash Safety	7.3	
Vibration	8.0	Aircraft type 1 (helicopter) tested to category U Aircraft type 2 through 6 tested to category S
Explosion	9.0	Equipment identified as Category X, no test required
Waterproofness	10.0	Equipment identified as Category X , no test required

Environmental Qualification (cont.)

Conditions	Section	Description of Conducted Tests
Fluids Susceptibility	11.0	Equipment identified as Category X, no test required
Sand and Dust	12.0	Equipment identified as Category X, no test required
Fungus	13.0	Equipment identified as Category X, no test required
Salt Spray	14.0	Equipment identified as Category X, no test required
Magnetic Effect	15.0	Equipment tested to Class Z
Power Input	16.0	Equipment tested to Category B
Voltage Spike	17.0	Equipment tested to Category A
Audio Frequency Susceptibility	18.0	Equipment tested to Category B
Induced Signal Susceptibility	19.0	Equipment tested to Category A
Radio Frequency Susceptibility	20.0	Equipment tested to Category T
Radio Frequency Emissions	21.0	Equipment tested to Category B and M
Lightning Induced Transient Susceptibility	22.0	Equipment tested to Category A3C3
Lightning Direct Effects	23.0	Equipment identified as Category X, no tests required
Icing	24.0	Equipment identified as Category X, no test required