

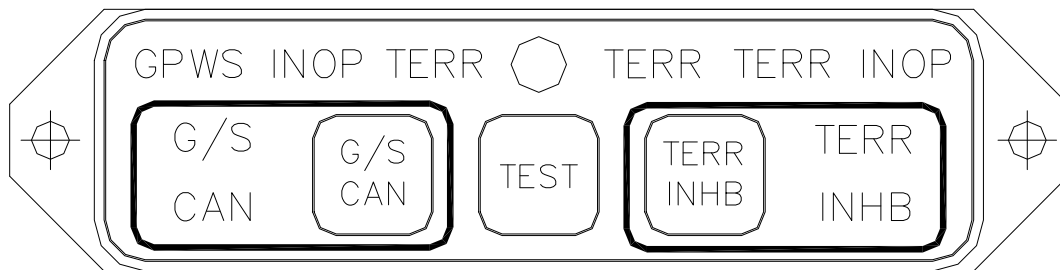

INSTALLATION MANUAL AND OPERATING INSTRUCTIONS

MD41-1348 Series Terrain Awareness Annunciation Control Unit for the Honeywell Mark XXII EGPWS System

MFG. P/N: MD41-1344	14VDC	Horizontal Mount, (shown on page 11)
MFG. P/N: MD41-1354	14VDC	Vertical Mount, (shown on page 11)
MFG. P/N: MD41-1348	28VDC	Horizontal Mount, (shown on page 11)
MFG. P/N: MD41-1348(5V)	28VDC	Horizontal Mount, 5 volt lighting
MFG. P/N: MD41-1358	28VDC	Vertical Mount, (shown on page 11)
MFG. P/N: MD41-1358(5V)	28VDC	Vertical Mount, 5 volt lighting



Mid-Continent Instruments and Avionics
9400 E. 34th Street N., Wichita, KS 67226 USA
Phone 316-630-0101 • Fax 316-630-0723

Manual Number 9016170
REV A, Apr. 22, 2005

Revision Detail

Rev.	Date	Detail
A	04/22/05	Complete issue

TABLE OF CONTENTS

SECTION 1	GENERAL DESCRIPTION
1.1	INTRODUCTION
1.2	SPECIFICATIONS, TECHNICAL
1.2.1	PHYSICAL CHARACTERISTICS
1.2.2	ENVIRONMENTAL CHARACTERISTICS
1.2.3	SPECIFICATIONS, ELECTRICAL
1.2.4	FRONT PANEL CONTROLS AND ANNUNCIATIONS
1.2.4.1	CONTROLS
1.2.4.2	ANNUNCIATIONS
1.2.5	EQUIPMENT LIMITATIONS
1.2.6	MAJOR COMPONENTS
SECTION 2	INSTALLATION CONSIDERATIONS
2.1	COOLING
2.2	EQUIPMENT LOCATION
2.3	ROUTING OF CABLES
SECTION 3	INSTALLATION PROCEDURE
3.1	GENERAL INFORMATION
3.2	UNPACKING AND INSPECTING EQUIPMENT
3.3	MOUNTING THE MD41-()
3.4	INSTALLATION LIMITATIONS
SECTION 4	POST INSTALLATION CHECKOUT
4.1	PRE-INSTALLATION TEST
4.2	OPERATING INSTRUCTIONS
SECTION 5	INSTRUCTIONS FOR CONTINUED AIRWORTHINESS
5.1	INTRODUCTION
5.2	CONTROL, OPERATION INFORMATION
5.3	MAINTENANCE INSTRUCTIONS
5.4	TROUBLESHOOTING INFORMATION
5.5	REMOVAL AND REPLACEMENT INFORMATION
5.6	DIAGRAMS
5.7	SPECIAL INSPECTION REQUIRMENTS
5.8	SPECIAL TOOLS
5.9	OVERHAUL PERIOD

Table of Contents (cont.)

FIGURE NO.	LIST OF ILLUSTRATIONS
3.1	SCHEMATIC PINOUT, 25 PIN DSUB
3.2	OUTLINE DRAWING
3.3	WIRING DIAGRAM, MD41-1344, -1354
3.4	WIRING DIAGRAM, MD41-1348, -1358(5V) -1348, -1358(5V)
3.5	SCHEMATIC DIAGRAM, MD41-1348

APPENDIX
ENVIRONMENTAL QUALIFICATION FORM

SECTION 1 GENERAL DESCRIPTION

1.1 INTRODUCTION

The MD41-1300 series are compact, self-contained Annunciation and Control Units (ACU). The fully integrated, control units provides annunciation and mode selection for both TAWS (Terrain Awareness Warning System) and EGPWS (Enhanced Ground Proximity Warning systems).

Other features include dual 20,000 hour lamps used for all annunciations, internally lighted selection switches and choice of manual or automatic photocell dimming. An external annunciation dimming adjustment is provided for balancing low level light conditions.

1.2 SPECIFICATIONS, TECHNICAL

1.2.1 PHYSICAL CHARACTERISTICS

Mounting:	Panel
Width:	3.25 Inches
Height:	0.80 Inches
Depth:	3.20 Inches
Weight:	0.50 lbs.

1.2.2 ENVIRONMENTAL CHARACTERISTICS

TSO Compliance:	C151a
Applicable Documents:	RTCA DO-160D
Operating Temperature Range:	-55°C to +70°C
Humidity:	95% Non-Condensing
Altitude Range:	0 to 55,000 ft.
Operational Shock:	Rigid Mounting, 6 G Operational 20 G Crash Safety

1.2.3 SPECIFICATIONS, ELECTRICAL

Design	All Solid State
MD41-1344, -1354	0.30 Amps
MD41-1348, -1358	0.30 Amps
MD41-1348(5V), -1358(5V)	0.40 Amps

1.2.4 FRONT PANEL CONTROLS AND ANNUNCIATIONS

1.2.4.1 CONTROLS

G/S/CAN	Momentary Switch used to manually inhibit EGPWS mode 5 glideslope alerts.
TEST	Momentary switch, when pressed, will activate the EGPWS computer self-test.
TERR/INHB	Alternate action switch provides for manual selection of terrain inhibit mode.

1.2.4.2 ANNUNCIATIONS

GPWS/INOP (amber)	When annunciated, indicates the EGPWS GPWS modes have a disabled function.
G/S CAN (amber)	When annunciated, indicates that the mode 5 glideslope alerts have been canceled.
TERR/INHB (green)	When annunciated, indicates that the EGPWS terrain functions have been inhibited.
TERR/INOP (amber)	When annunciated, indicates that the EGPWS terrain modes have a disabled function.
TERR (amber)	When annunciated, Terrain is very near or above aircraft altitude.
TERR (red)	When annunciated, Terrain is well above aircraft altitude.

1.2.5 EQUIPMENT LIMITATIONS

The MD41-1300 series control units contain specific dash numbers to be used with various Terrain Awareness Warning Systems. The installer must match the correct controller part number with the system that is being installed.

The MD41-1344, -1354, -1348, -1348(5V), -1358, -1358(5V) is TSO'D and certified for use with the Honeywell Mark XXII EGPWS systems. Any attempts to install the listed units in an installation other than above system is prohibited. **This will void the TSO.**

NOTE: If the MD41-() is disconnected or removed from the aircraft, there will be no effect in the operation of the EGPWS system.

1.2.6 MAJOR COMPONENTS

This system is comprised of one major component, the MD41-1300 series TAWS Annunciation Control Unit.

SECTION 2 INSTALLATION CONSIDERATIONS

2.1 COOLING

No direct cooling is required. As with any electronic equipment, overall reliability may be increased if the MD41-1300 series ACU is not located near any high heat source or crowded next to other equipment. Means of providing a gentle air flow will be a plus.

2.2 EQUIPMENT LOCATION

The MD41-1300 series ACU must be mounted as close to the pilot's field of view as possible. Please reference the EGPWS installation manual for approved locations. The unit depth, with connector attached, must also be taken into consideration.

2.3 ROUTING OF CABLES

Care must be taken not to bundle the MD41-1300 series ACU logic and low level signal lines with any high energy sources. Examples of these sources include 400 HZ AC, Comm, DME, HF and transponder transmitter coax. Always use shielded wire when shown on the installation print.

Avoid sharp bends in cabling and routing near aircraft control cables.

SECTION 3 INSTALLATION PROCEDURES

3.1 GENERAL INFORMATION

This section contains interconnect diagrams, mounting dimensions and other information pertaining to the installation of the MD41-1300 series ACU. After installation of cabling and before installation of the equipment, ensure that power is applied only to the pins specified in the interconnect diagram.

3.2 UNPACKING AND INSPECTING EQUIPMENT

When unpacking equipment, make a visual inspection for evidence of damage incurred during shipment. The following parts should be included:

1. MD41-1344 (14volt) 14 volt button lighting Horizontal Mount or MD41-1354 (14volt) 14 volt button lighting Vertical Mount or MD41-1348 (28volt) 28 volt button lighting Horizontal Mount or MD41-1348(5v) (28volt) 5 volt button lighting Horizontal Mount or MD41-1358 (28volt) 28 volt button lighting Vertical Mount or MD41-1358(5v) (28volt) 5 volt button lighting Vertical Mount
2. J1 Connector Kit (25 pin). MCI P/N 7014517
3. Installation Manual. MCI P/N 9016170

3.3 MOUNTING THE MD41-()

Avoid mounting close to heater vents or other high heat sources. Allow a clearance of at least 3 inches from back of unit for plug removal.

The indicator is secured in place behind the panel since it is designed for rear mount only. Make a panel cutout as shown in Figure 3-2. Secure the indicator in place with two 4-40 x 3/8 flat head phillips screws.

3.4 INSTALLATION LIMITATIONS

Wire the aircraft harness according to figure 3-3. Use at least 24 AWG wire for all connections. Avoid sharp bends and routing cable near high-energy sources. Care must be taken to tie the harness away from aircraft controls and cables. Also see equipment limitations, section 1.2.5.

“The TSO identifies the minimum performance standards, tests and other conditions applicable for issuance of design and production approval of the article. The TSO does not specifically identify acceptable conditions for installations of the article. The TSO applicant is responsible for documenting all limitations and conditions suitable for installation of the article. An applicant requesting approval for installation of the article within a specific type or class of product is responsible for determining environmental and functional compatibility.”

This Annunciation Control Unit is part of an incomplete system. The intended function is to provide required or optional annunciation and mode selection for Class A or B TAWS systems.

J1 CONNECTOR

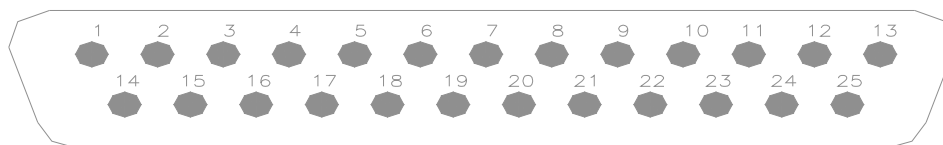

REAR VIEW OF J1 CONNECTOR

J1
PIN NO.

1 -----	GPWS INOP annunciate input. Receives logic low to annunciate.
2 -----	TERR INOP annunciate input. Receives logic low to annunciate.
3 -----	Spare
4 -----	Spare
5 -----	TERR CAUTION annunciate input. Receives logic low to annunciate.
6 -----	LAMP TEST (receives ground from remote test switch)(optional conn).
7 -----	Bright/Dim annunciation lamp power.
8 -----	Push Button Lighting. To 14V, 28V or 5Vdc lighting buss. (depends on dash number of ACU)
9 -----	Ground for push-button backlighting.
10 -----	Spare
11 -----	TERR WARNING annunciate input. Receives logic low to annunciate.
12 -----	Internal photocell dimming output. To use, jumper pin 12 to pin 7.
13 -----	14Vdc or 28 Vdc unit power. (depends on dash number) 300 mA max.
14 -----	Spare
15 -----	Spare
16 -----	Spare
17 -----	G/S CANCEL annunciate input. Receives logic low to annunciate.
18 -----	G/S CANCEL switch. Momentary switch, provides ground output when pressed.
19 -----	Terrain Self-Test switch. Momentary switch, provides ground output when pressed.
20 -----	Terrain Inhibit select switch. Alternate action switch, provides ground output to select.
21 -----	Power Ground
22 -----	Spare
23 -----	Spare
24 -----	Spare
25 -----	Spare

FIGURE 3-1 SCHEMATIC PINOUT, 25 PIN DSUB

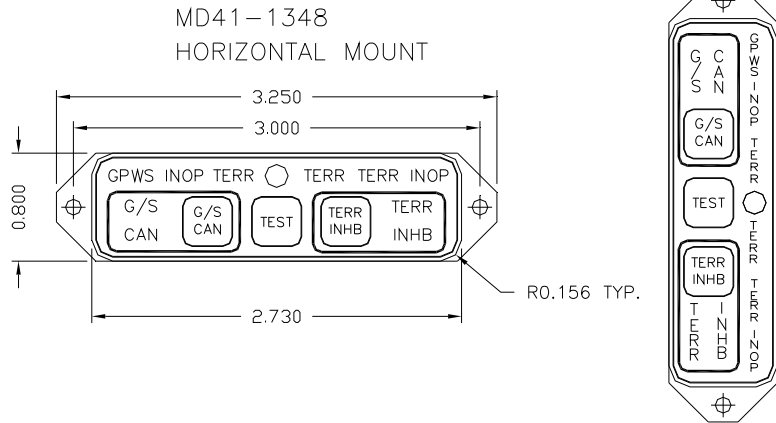
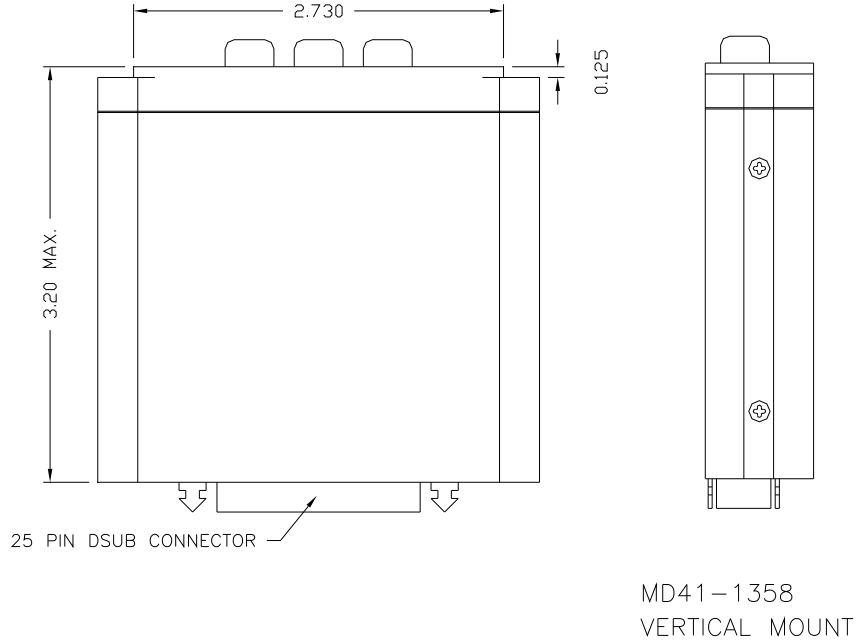

- COLORS:
- G/S CAN: AMBER
 - GPWS INOP: AMBER
 - TERR: RED
 - TERR: AMBER
 - TERR INOP: AMBER
 - TERR INHB: GREEN

Note 1: Use two 4-40 X 3/8" Flat Head Phillips Screws for Mounting

FIGURE 3-2 OUTLINE DRAWING

MD41-1344, -1354
ANNUNCIATION-CONTROL

HONEYWELL
MARK XXII

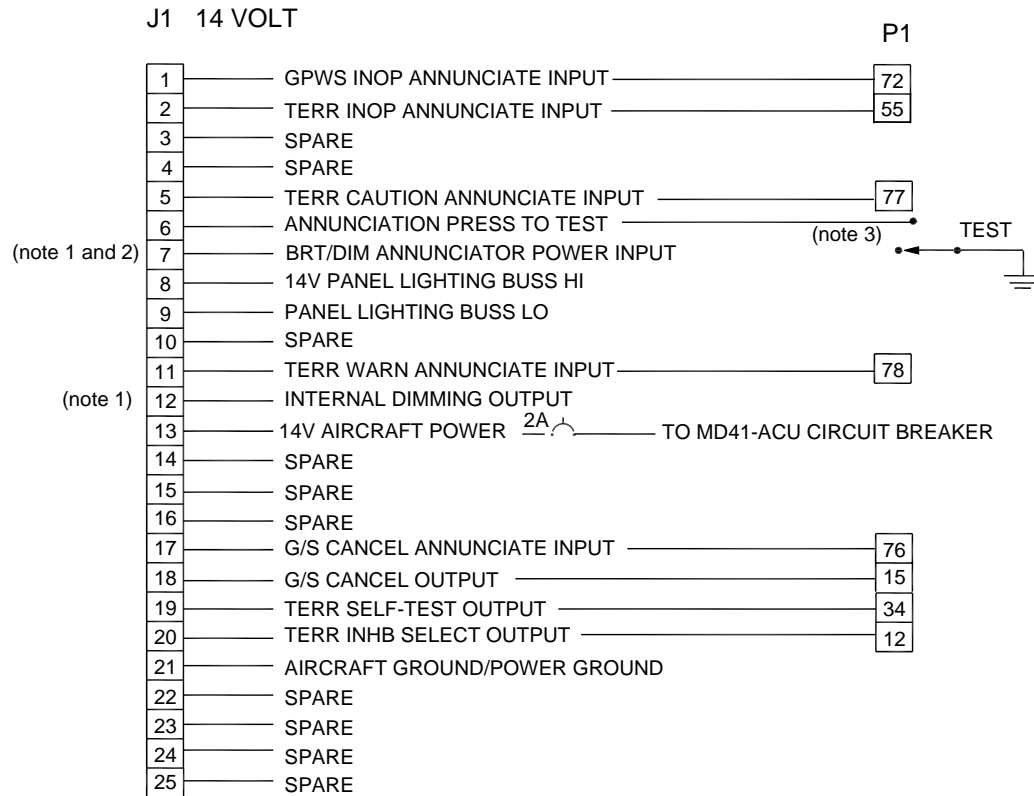

NOTES:

- 1) JUMPER 7 TO 12 FOR ANNUNCIATION BRIGHTNESS TO BE CONTROLLED BY INTERNAL PHOTOCELL C PIN 7 MAY BE CONNECTED TO AIRCRAFT BRT/DIM SWITCH
- 2) ANNUNCIATOR POWER MUST BE SELECTED SO THAT ANNUNCIATORS ARE VISIBLE UNDER ALL LIGHTING CONDITIONS.
- 3) MOMENTARY SWITCH FOR LAMP TEST. (optional connection)
- 4) REFER TO HONEYWELL MARK XXII INSTALLATION MANUAL FOR ACTUAL INSTALLATION.

FIGURE 3-3 WIRING DIAGRAM, MD41-1344, -1354

MD41-1348, -1358, -1348(5V), -1358(5V)
ANNUNCIATION-CONTROL

HONEYWELL
MARK XXII

J1 28 VOLT

P1

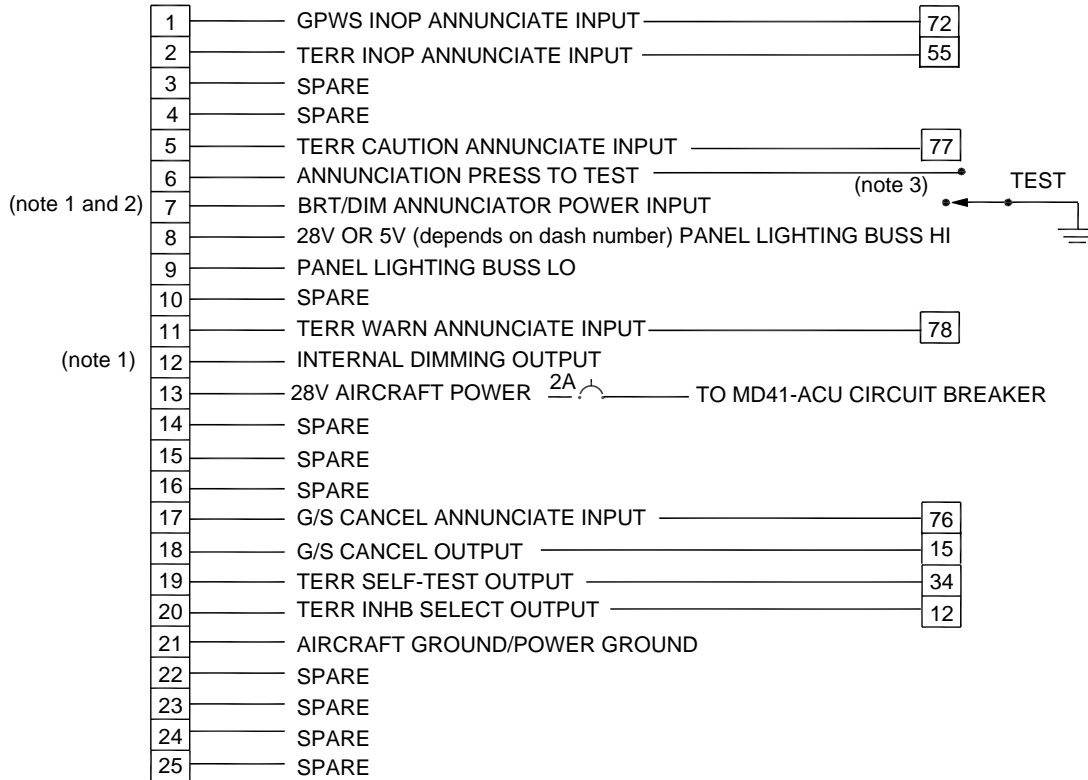

NOTES:

- 1) JUMPER 7 TO 12 FOR ANNUNCIATION BRIGHTNESS TO BE CONTROLLED BY INTERNAL PHOTOCCELL OR PIN 7 MAY BE CONNECTED TO AIRCRAFT BRT/DIM SWITCH
- 2) ANNUNCIATOR POWER MUST BE SELECTED SO THAT ANNUNCIATORS ARE VISIBLE UNDER ALL LIGHTING CONDITIONS.
- 3) MOMENTARY SWITCH FOR LAMP TEST. (optional connection)
- 4) REFER TO HONEYWELL MARK XXII INSTALLATION MANUAL FOR ACTUAL INSTALLATION.

**FIGURE 3-4 WIRING DIAGRAM, MD41-1348, -1348(5V),
-1358, -1358(5V)**

SECTION 4 POST INSTALLATION CHECKOUT

4.1 PRE INSTALLATION TESTS

With the MD41-1300 disconnected, turn on the avionics master switch and verify that aircraft power is on pin 13 for. Using an ohm-meter, verify pin 25 is aircraft ground.

4.2 OPERATING INSTRUCTIONS

Refer to the Mark XXII EGPWS pilots guide or installation manual for final testing of the MD41-1300. Unit should be tested in accordance with the Mark XXII preflight test procedure.

SECTION 5 INSTRUCTIONS FOR CONTINUED AIRWORTHINESS

5.1 INTRODUCTION

This document identifies the instructions for Continued Airworthiness for the MD1300 series TAWS Annunciation Control Unit.

5.2 CONTROL, OPERATION INFORMATION

Refer to the Honeywell Mark XXII Pilots Guide and section 1.2.4 of this manual.

5.3 MAINTENANCE INSTRUCTIONS

Repair of the MD41-1300 ACU is “on condition only”, periodic maintenance is not required.

Calibration and inspection intervals are not required. Service life shall be a minimum of 20,000 hours.

5.4 TROUBLESHOOTING INFORMATION

Refer to the MD41-1300 series Maintenance Manual.

5.5 REMOVAL AND REPLACEMENT INFORMATION

If the unit is removed and reinstalled, a functional check of the equipment should be conducted in accordance with the Mark XXII preflight test procedure.

5.6 DIAGRAMS

Refer to figure 3-2, 3-3 and 3-4 of this manual.

5.7 SPECIAL INSPECTION REQUIRMENTS

N/A

5.8 SPECIAL TOOLS

None

5.9 OVERHAUL PERIOD

No overhaul time limitations.

ENVIRONMENTAL QUALIFICATION FORM

RTCA / DO160D

NOMENCLATURE: MD41-() TERRAIN AWARENESS ANNUNCIATION CONTROL
UNIT

MODEL NO: MD41-()

TSO C151a

MANUFACTURER: Mid-Continent Instruments and Avionics
9400 E. 34th Street N.
Wichita, KS 67226
Phone (316) 630-0101

Conditions	Section	Description of Conducted Tests
Temperature and Altitude Low Temperature High Temperature In-Flight Loss of Cooling Altitude Decompression Overpressure	4.0 4.5.1 4.5.2 & 4.5.3 4.5.4 4.6.1 4.6.2 4.6.3	Equipment tested to Category A1 and F2 Cooling air not required Not Tested Note: DO160D section 4.0 is equivalent to already tested DO160C section 4.0
Temperature Variation	5.0	Equipment tested to Category C Note: DO160D section 5.0, category C is equivalent to already tested DO160C section 5.0, category C
Humidity	6.0	Equipment tested to Category A Note: DO160D section 6, category A is equivalent to already tested DO160C section 6, category A
Shock Operational Crash Safety	7.0 7.2 7.3	Equipment tested to Category B
Vibration	8.0	Aircraft type 1 (helicopter) tested to category U Aircraft type 2 through 6 tested to category S
Explosion	9.0	Equipment identified as Category X, no test required
Waterproofness	10.0	Equipment identified as Category X , no test required

Environmental Qualification (cont.)

Conditions	Section	Description of Conducted Tests
Fluids Susceptibility	11.0	Equipment identified as Category X, no test required
Sand and Dust	12.0	Equipment identified as Category X, no test required
Fungus	13.0	Equipment identified as Category X, no test required
Salt Spray	14.0	Equipment identified as Category X, no test required
Magnetic Effect	15.0	Equipment tested to Class Z Note: DO160D section 15.0 is equivalent to already tested DO160C section 15.0
Power Input	16.0	Equipment tested to Category B
Voltage Spike	17.0	Equipment tested to Category A Note: DO160D section 17.0, category A is equivalent to already tested DO160C section 17.0, category A
Audio Frequency Susceptibility	18.0	Equipment tested to Category B Note: DO160D section 18.0, category B is equivalent to already tested DO160C section 18.0, category B
Induced Signal Susceptibility	19.0	Equipment tested to Category A Note: DO160D section 19.0, category A is equivalent to already tested DO160C section 19.0, category A
Radio Frequency Susceptibility	20.0	Equipment tested to Category T
Radio Frequency Emissions	21.0	Equipment tested to Category B and M
Lightning Induced Transient Susceptibility	22.0	Equipment tested to Category A3C3
Lightning Direct Effects	23.0	Equipment identified as Category X, no tests required
Icing	24.0	Equipment identified as Category X, no test required