



INSTALLATION MANUAL AND OPERATING INSTRUCTIONS

MD50-() Series Static Electrical Power Inverter



REV. D February 24, 2011

Manual Number 9017039

Mid-Continent Instruments and Avionics
9400 E. 34th Street N., Wichita, KS 67226 USA
phone 316-630-0101 • fax 316-630-0723 • web www.mcico.com

FOREWORD

This manual provides information intended for use by persons who, in accordance with current regulatory requirements, are qualified to install this equipment. If further information is required, please contact:

Mid-Continent Instruments and Avionics
Attn: Customer Service Dept.
9400 E. 34th ST North
Wichita, KS 67226 USA
Phone 316-630-0101 Fax 316-630-0723

We welcome your comments concerning this manual. Although every effort has been made to keep it free of errors, some may occur. When reporting a specific problem, please describe it briefly and include the manual part number, the paragraph/figure/table number, and the page number. Send your comments to:

Mid-Continent Instruments and Avionics
Attn: Technical Publications
9400 E. 34th ST North
Wichita, KS 67226 USA
Phone 316-630-0101, Fax 316-630-0723
info1@mcico.com
www.mcico.com

© Copyright 2010
Mid-Continent Instruments and Avionics

REVISION DETAIL

Rev.	Date	Approved	Detail
A	02/26/10	BAW/JRC	Initial release.
B	07/06/10	BAW/MKN	Update Section 2.4 to add limitation statement regarding output.
C	07/20/10	MKN/BAW	Update unit picture with True Blue Power label.
D	02/24/11	JDS/BAW	Added section 3.3.2, and figure 3.4.

TABLE OF CONTENTS

SECTION 1 GENERAL DESCRIPTION

- 1.1 INTRODUCTION
- 1.2 TECHNICAL SPECIFICATIONS
 - 1.2.1 ELECTRICAL ATTRIBUTES
 - 1.2.2 PHYSICAL ATTRIBUTES
 - 1.2.3 QUALIFICATIONS

SECTION 2 INSTALLATION CONSIDERATIONS

- 2.1 COOLING
- 2.2 EQUIPMENT LOCATION
- 2.3 ROUTING OF CABLES
- 2.4 LIMITATIONS

SECTION 3 INSTALLATION PROCEDURE

- 3.1 GENERAL INFORMATION
- 3.2 UNPACKING AND INSPECTING
- 3.3 CABLE HARNESS
 - 3.3.1 WIRE GAUGE SELECTION
 - 3.3.2 PIN ASSIGNMENT INFORMATION
 - 3.3.3 HARNESS VERIFICATION
- 3.4 MOUNTING
- 3.5 INSTALLATION COMPLETION

SECTION 4 OPERATION

- 4.1 ELECTRICAL PERFORMANCE
- 4.2 PROTECTIVE FEATURES

SECTION 5 CONFORMANCE

- 5.1 CONTINUED AIRWORTHINESS STATEMENT
- 5.2 ENVIRONMENTAL QUALIFICATION STATEMENT

NUMBER LIST OF TABLES AND FIGURES

- 1.1 MODELS TABLE
- 1.2 PHYSICAL ATTRIBUTES TABLE
- 1.3 PERFORMANCE TABLE
- 3.3 CONNECTOR PINOUT FIGURE
- 3.3 CONNECTOR PINOUT TABLE
- 3.4 EXAMPLE WIRING DIAGRAMS
- 3.5 MD50 OUTLINE DRAWING FIGURE
- 3.6 MD50 MOUNTING ADAPTER FIGURE
- 4.1 THD PERFORMANCE
- 4.2 TEMPERATURE PERFORMANCE

SECTION 1 GENERAL DESCRIPTION

1.1 INTRODUCTION

The model MD50 series Static Electrical Power Inverter is a lightweight power converter that translates a 20 to 36 VDC input to a 115 VAC output at 60 Hertz and provides 500 watts (VA) of power. The alternating current output is defined as a pure sine wave with less than 3% of total harmonic distortion for clean, noise-free, harmonic-free power to supply nearly any common commercial or consumer load rated for a nominal input of 115VAC. The MD50 series Inverter is FAA certified to TSO C73 and tested to rigorous environmental standards and levels of RTCA DO-160. The small size and light weight in conjunction with its installation flexibility inside or outside the pressure vessel make it an ideal choice for aircraft power needs while reducing the challenges associated with other similar products.

Highlighted features include short circuit protection, overload capability, low voltage shut-down, temperature monitoring, a self-resettable over-temperature disable, and a remote on/off function. The rugged extrusion that houses the unit is designed to help dissipate heat and provide mechanical strength against vibration or other possibilities of damage. Two independent fans allow for a smaller unit and provide a quieter operation while keeping the internal components cool and extending the life of the unit.

1.2 TECHNICAL SPECIFICATIONS

1.2.1 ELECTRICAL ATTRIBUTES

Characteristics:	
Input Voltage:	Rated 28VDC nominal; 20-36VDC certified
Input Power:	17-25 amps; 0.2A at no load
Output Voltage:	115VAC \pm 3% at 60 Hertz \pm 0.1% (single phase)
Output Power:	500 watts (500 VA at power factor = 1)
Output Waveform:	Pure sine wave
Power Factor:	-0.8 to +0.8
Efficiency:	88% nominal
Total Harmonic Distortion (THD):	< 3%; See Figure 4.1

Table 1.1

1.2.2 PHYSICAL ATTRIBUTES

Characteristics:	
Weight:	3.9 pounds
Dimensions: (not including connector mate)	6.71 inches long (8.15 inches – mounting base) 6.34 inches wide 2.74 inches high
Mating Connector (and cable clamp):	MS3106A-18-9S or equivalent (MCI P/N 9016905-1 and -2)
Mounting:	Base mount – orientation not critical

Table 1.2

1.2.3 QUALIFICATIONS

Specifications:	
Qualification:	FAA TSO-C73
Environmental Qualification:	RTCA DO-160F Environmental Category F3(Y)S2BB(RCC1)XXXXXXZXXXXXBXXXXX
Altitude:	-15,000 ft to +55,000 ft
Temperature:	-55°C to +70°C (-67°F to +158°F); See Figure 4.2

Table 1.3

SECTION 2 PRE-INSTALLATION CONSIDERATIONS

2.1 COOLING

No external cooling is required. The unit is equipped with two internal brushless DC fans. Restriction to airflow can cause overheating of the unit and limit performance or reduce the expected life of the product. Make sure to provide adequate clearance on both ends of the unit with the hexagonal openings to allow for proper circulation. In general, four to six inches of clearance on both ends of the unit should be acceptable. Mounting the unit to a metal surface can also help reduce the effects of temperature within the unit but is not required.

2.2 EQUIPMENT LOCATION

The MD50 Static Inverter is designed for mounting flexibility, allowing for installation inside or outside the pressure vessel with no requirement for temperature control. In addition to altitude and temperature resistance, the unit is also designed to withstand high levels of condensing humidity. However, installation locations where the unit could be subject to standing or direct water exposure should be avoided. The unit can be mounted in any orientation. Clearance should be provided for the mating connector and may require as much as four to five inches past the unit connector to allow for the backshell, access to the connector, and appropriate wire bends.

2.3 ROUTING OF CABLES

The wires and cable bundle associated with the unit are heavy gauge wire and carry significant power. Be aware of routing cables near other electronics or with other wire bundles that may be susceptible to high energy flow.

Avoid sharp bends in cabling and routing near aircraft control cables. Also avoid proximity and contact with aircraft structures, avionics equipment, or other obstructions that could chafe wires during flight and cause undesirable effects.

2.4 LIMITATIONS

The MD50-() Series of static electric power inverters is certified to FAA TSO-C73 with the following limitations identified:

- 1) Alternating current (AC) output is provided at 115 volts and 60 hertz in lieu of 115 volts and 400 hertz as identified in the MPS of the TSO.
- 2) Equivalent environmental qualification was verified per RTCA DO-160F in lieu of those identified within the MPS of the TSO.

The conditions and tests for TSO approval of this article are minimum performance standards. Those installing this article, on or in a specific type or class of aircraft, must determine that the aircraft installation conditions are within the TSO standards, specification of the article, and deviations as listed above. TSO articles must have separate approval for installation in an aircraft. The article may be installed only according to 14 CFR part 43 or the applicable airworthiness requirements.

SECTION 3 INSTALLATION PROCEDURES

3.1 GENERAL INFORMATION

This section contains interconnect diagrams, mounting dimensions and other information pertaining to the installation of the MD50 Static Inverter. After installation of cabling and before installation of the equipment, ensure that power is applied only to the pins specified in the interconnect diagram.

3.2 UNPACKING AND INSPECTING EQUIPMENT

When unpacking this equipment, make a visual inspection for evidence of any damage that may have incurred during shipment. The following parts should be included:

- | | |
|---------------------------------------|-----------------------------------|
| a. Static Inverter – | MCI P/N MD50 [or MD50-()] |
| b. Mating Connector (& cable clamp) – | MCI P/N 9016905-1 (and 9016905-2) |
| c. Installation Manual – | MCI P/N 9017039 |

Optional equipment available:

- | | |
|---------------------------|-----------------|
| a. Mounting Adapter Kit – | MCI P/N 9017040 |
|---------------------------|-----------------|

Equipment not provided:

- | | |
|-------------------------|--|
| a. Mounting Hardware – | four (4) #10-32 pan head screws
#10 lock washers (optional) |
| b. Cable Harness Wire – | See Section 3.3 for specification |

3.3 CABLE HARNESS

Construct the cable harness with regards to the instructions below, and using the Connector Pinout of Figure 3.3, Figure 3.4, and Wiring Diagram of Table 3.3.

Refer to Section 2: Pre-Installation Considerations in regards to routing precautions.

3.3.1 WIRE GAUGE SELECTION

Use of PTFE, ETFE, TFE, Teflon, or tefzel insulated wire is recommended for aircraft use. Use the following wire gauges for each of the pins in the connector:

- Pin A and D – 12 AWG stranded or solid
- Pin B and C – 16 AWG stranded or solid
- Pin E and G – 16-24 AWG stranded or solid

3.3.2 PIN ASSIGNMENT INFORMATION

INPUT POWER:

Pin A – Positive DC input +24 to 32 VDC. Connect to the aircraft 28 VDC bus using a 25 or 30 Amp circuit breaker.

Pin D – Negative DC input. Internally this pin is connected to the inverter enclosure. Connect to aircraft ground.

INVERTER OUPUT:

Pin B – AC Output 115VAC, 60Hz. Used for powering devices where terrestrial/utility power designations are used, pin B can be connected as “Line” or “Hot”.

Pin C – AC Return 115VAC, 60Hz. Used for powering devices where terrestrial/utility power designations are used, pin C can be connected as “Neutral”.

Note: Use of a circuit breaker on the AC output is optional. For the full inverter 500VA output, a 5 Amp circuit breaker is sufficient. For convenience at each AC outlet, individual circuit breakers of 1 to 2 amps each can be used. If a single pole breaker is used, install the breaker on the wire from pin B. If a double pole breaker is installed, route both pins B and C through the circuit breaker.

REMOTE ON/OFF CONTROL: (see section 4.2.1)

Pin E – Remote ON/OFF Control. Connecting this pin to either DC Negative or to inverter pin G will enable the AC output of the inverter. By utilizing a switch between this pin and ground or negative, it will allow remote on/off control of the unit. When unconnected (output is OFF) this pin will have approximately 11 VDC present, internally limited to less than 1 mA. If the inverter is to be enabled at all times, pin E can be connected to pin G.

Pin G – Remote ON/OFF Return. This pin is internally connected to pin D and the enclosure. Pin G can be used as the return from an ON/OFF switch or left unconnected. It is recommended that pin G not be connected directly to ground or 28V negative.

Pin F – Reserved. Do not use.

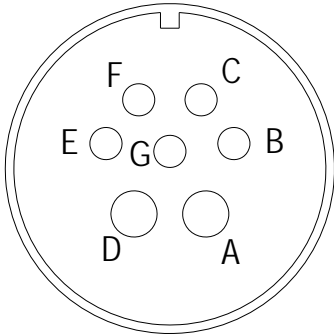

FIGURE 3.3

**PINOUT VIEW OF
UNIT CONNECTOR**

Connector Pinout	
Pin #	
A	24-32VDC Input
B	115VAC Output
C	Output Return
D	Input Return
E	Remote On/Off
F	Reserved
G	Remote Return

TABLE 3.3

CONNECTOR PINOUT

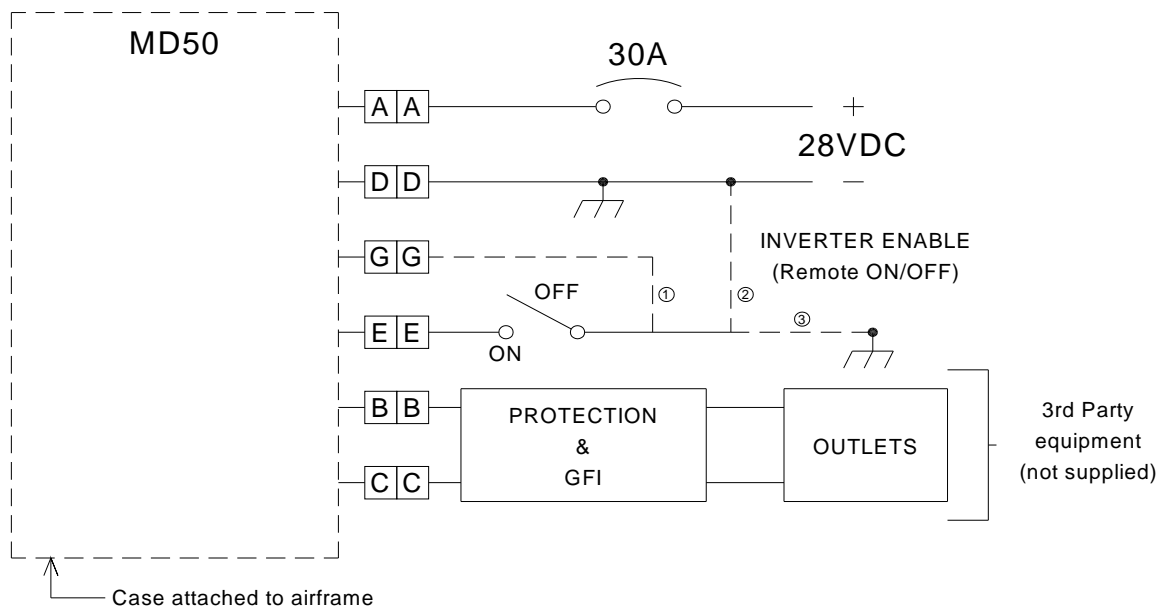
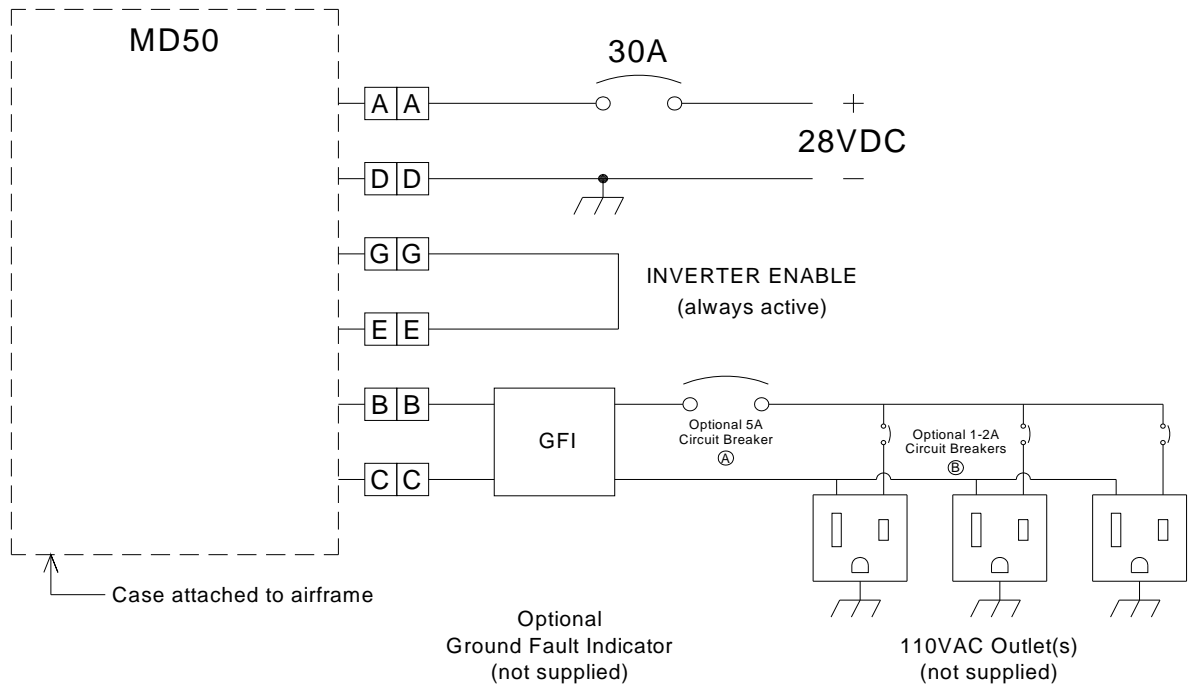

Notes:

1. Wiring diagrams above represent various examples of typical installations.
2. Recommended to attach case to metal aircraft structure.
3. Recommended outlet protection may consist of either:
 - A. single 5A circuit breaker for all outlet(s) (single or double pole breaker), **OR**
 - B. 1-2A circuit breakers for each outlet
4. For Remote On/Off operation, return line can be configured in one of three ways:
 1. return line connected to pin G
 2. return line connected to pin D
 3. return line connected to aircraft ground

FIGURE 3.4
EXAMPLE WIRING DIAGRAMS

3.3.3 HARNESS VERIFICATION

With the MD50 Static Inverter disconnected, activate the aircraft power bus that supplies the unit and use an multi-meter to verify that aircraft power and ground with appropriate voltage is on the pins within the mating harness.

3.4 MOUNTING

Refer to Section 2: Pre-Installation Considerations in regards to equipment location.

The MD50 Static Inverter is designed for base mounting only. Four #10-32 mounting holes should be provided in the aircraft in accordance with Figure 3.5. If installing the MD50 as a replacement for legacy static inverters, an optional Mounting Adapter Kit adapter plate is available to utilize the same mounting hole locations. See figure 3.6 for mounting hole locations using the Mounting Adapter Kit and Section 3.2 for the Mounting Adapter Kit part number. Secure the unit with four #10-32 pan head phillips screws or equivalent. A lock washer under the head of each screw is recommended.

3.5 INSTALLATION COMPLETION

Prior to operating the unit in the aircraft, it is recommended to verify the output and functionality of the unit. In order to prevent accidental damage to other systems, it is best not attach the output to other equipment or power busses prior to verification. Verify the output of the unit at the terminating end of the cable with a multimeter to ensure proper voltage and polarity. Once verified, installation can be completed and functionality of the remote on/off feature (if used) should be checked.

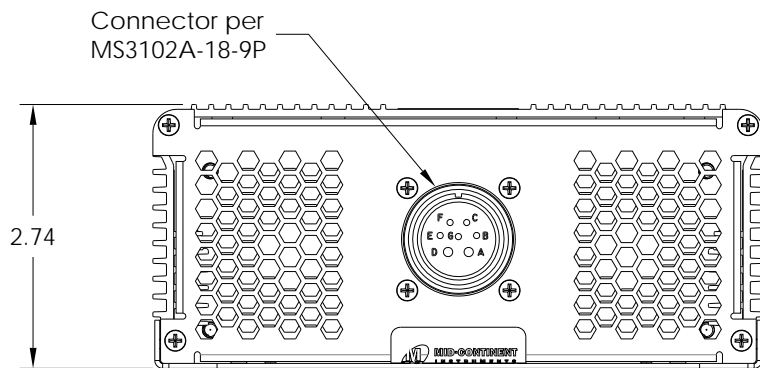
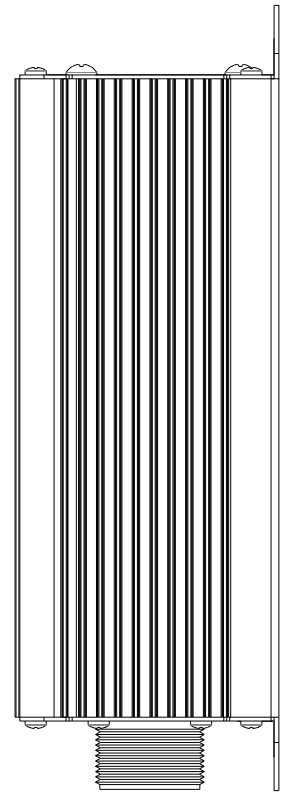
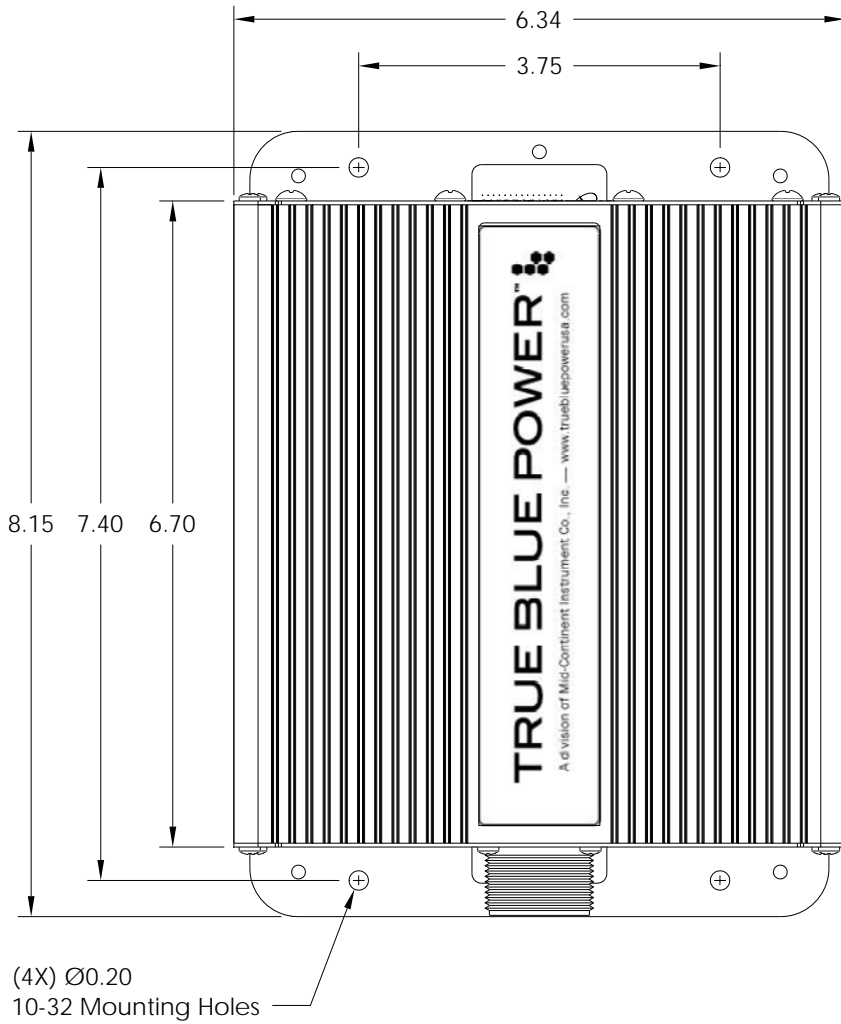
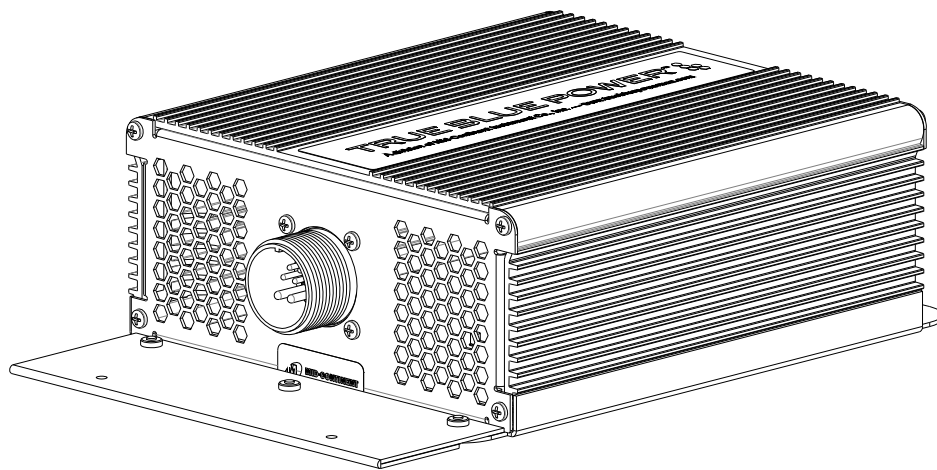
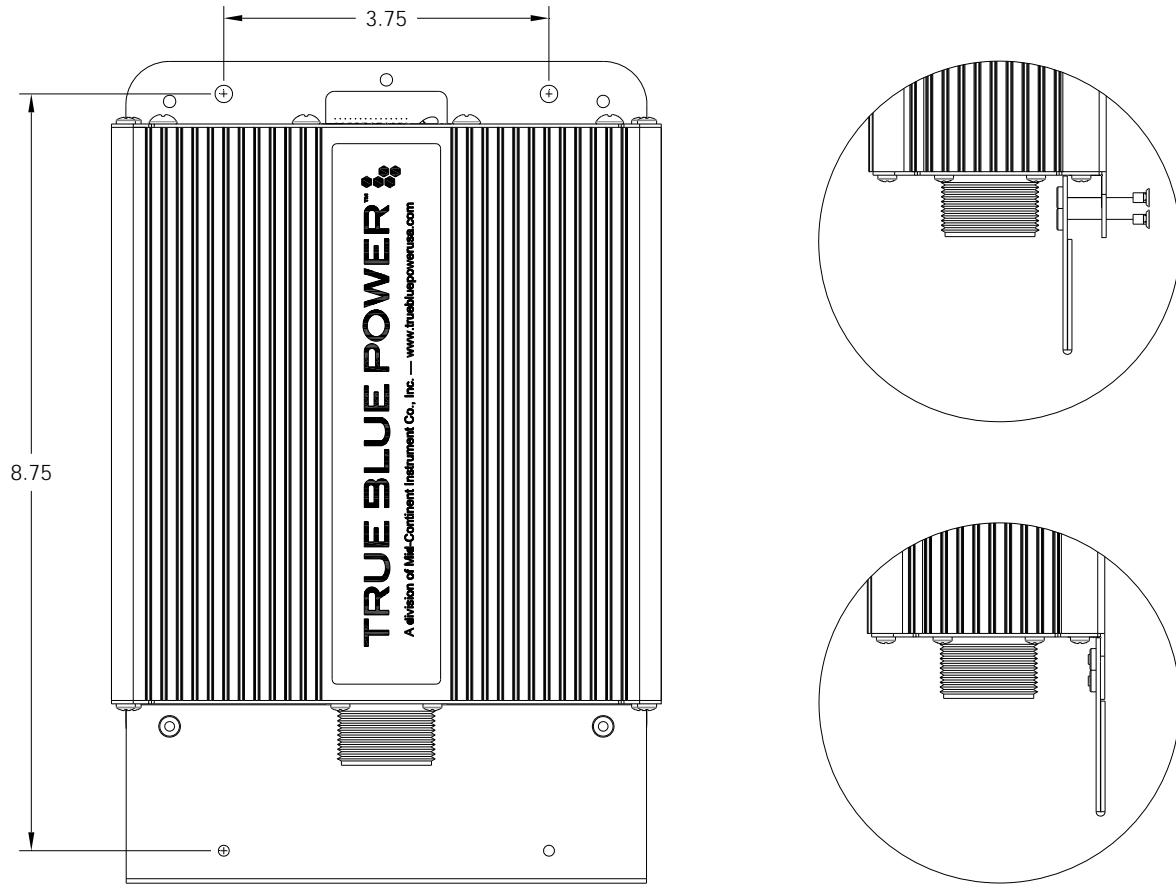

FIGURE 3.5
MD50 OUTLINE DRAWING



NOTE: Mounting adapter can be installed on either end of the unit.

FIGURE 3.6
MD50 MOUNTING ADAPTER

SECTION 4 OPERATION

4.1 ELECTRICAL PERFORMANCE

The MD50 series Static Inverter converts a direct current (DC) voltage input to a regulated 115 volt alternating current (VAC) output. The output is controlled to a frequency of 60 Hertz and represents a pure sine wave with minimal distortion. The unit is capable of providing 500 watts to power a variety of aircraft accessories including laptops, personal electronics, onboard systems, and many others. (See Section 1.2.1 for tolerance ranges)

The unit is designed as a two-stage, solid-state switch-mode power supply. The power transformation utilizes a first-stage push-pull methodology followed by an H-bridge AC forming second stage. The primary stage utilizes 'current-mode' control providing instantaneous load protection as an advantage over legacy designs that incorporate 'voltage-mode' controllers. The alternating current is frequency controlled using a crystal oscillator reference.

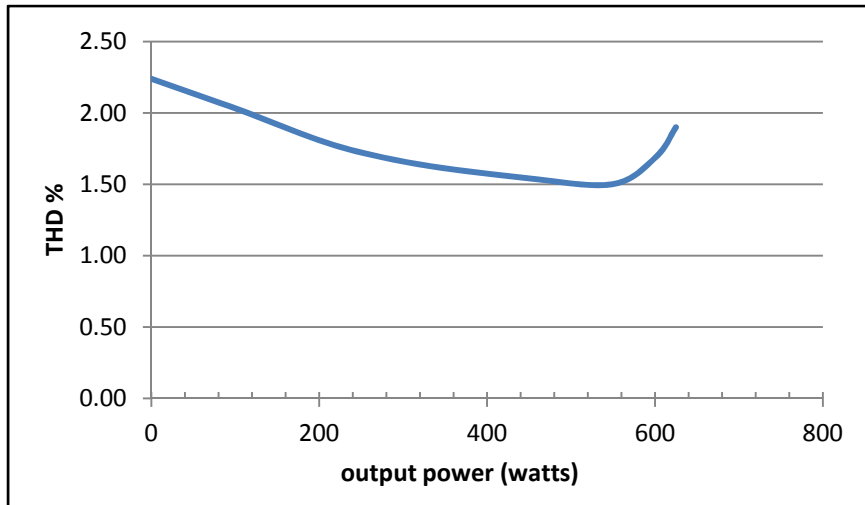

Figure 4.1 Total Harmonic Distortion Performance vs Load

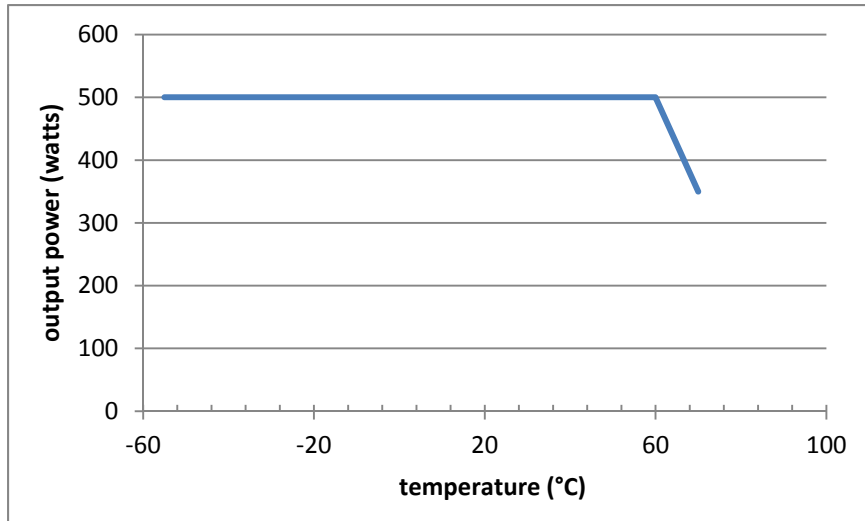

Figure 4.2 Output Power Performance vs Temperature

4.2 **PROTECTIVE FEATURES**

4.2.1 **REMOTE ON/OFF**

The MD50 series Static Inverter incorporates a remote on/off feature that allows the user to enable or disable the output of the unit. By providing a ground on the appropriate pin (See Table 3.3) the user, via a remote mounted switch or similar method, can enable the output of the unit. The unit can be similarly disabled by removing the ground signal (open circuit) to the same pin.

4.2.2 **OVER-VOLTAGE**

When the input voltage exceeds the operating range of the unit (See Section 1.2.1; absolute maximum input of 37VDC) the unit senses an over-voltage condition and disables the output. The unit will dynamically monitor the input voltage such that if the input returns to within the normal operating range, the output will be enabled and allow the unit to operate normally.

4.2.3 **UNDER-VOLTAGE**

When the input voltage drops below the operating range of the unit (See Section 1.2.1; absolute minimum input of 20VDC) the unit senses an under-voltage condition and disables the output. The unit will dynamically monitor the input voltage such that if the input returns to within the normal operating range, the output will be enabled and allow the unit to operate normally.

4.2.4 **OVER-TEMPERATURE**

The MD50 incorporates an internal temperature sensing device that continually provides monitoring and feedback to the control circuits. When the unit senses an internal condition that exceeds maximum temperature ratings, the output is disabled. The internal cooling fans will continue to operate and the unit output will be enabled when the temperature returns to within acceptable limits. This over-temperature reset occurs automatically without external intervention required.

4.2.5 **SHORT CIRCUIT AND OVER-CURRENT**

The MD50 is capable of surviving a short circuit or over-current event without permanent damage or effect to long-term reliability. The unit can provide over its rated power output up to 550 watts for up to 2 hours. The unit is also capable of supporting an overload condition of 750 watts for 5 minutes with distortion of the sine wave and reduced voltage output. The unit monitors on pulse-by-pulse scenario to determine a short circuit or over-current situation. If detected, the output is limited by clipping the AC sine wave form, limiting the power output. The unit will also produce an audible clicking noise, indicating that the power output limit has been exceeded. When the short circuit or over-current event is removed, the unit will return to normal operation.

4.2.6 **TEMPERATURE REGULATED COOLING**

The unit is equipped with two internal brushless DC fans for cooling to extend the power range and long-term life. The fans are activated at a specified point determined by the continuous monitoring of the internal temperature. The fans operate very quietly to reduce the audible noise in any environment. The two fans provide independent redundancy for protection of the unit in the event that one becomes inoperative.

The unit is also designed to provide 75% of the rated load continuously at temperatures up to +40°C in the event that both fans become inoperable and no cooling is available.

SECTION 5 CONFORMANCE

5.1 CONTINUED AIRWORTHINESS STATEMENT

No periodic scheduled maintenance or calibration is necessary for continued airworthiness of the MD50 series Static Inverter. If the unit fails to perform to specifications, the unit must be removed and serviced by Mid-Continent Instruments and Avionics or their authorized designee.

5.2 ENVIRONMENTAL QUALIFICATION STATEMENT

NOMENCLATURE: Static Electrical Power Inverter

MODEL NUMBER: MD50-() **TSO NUMBER:** C73

MANUFACTURERS SPECIFICATIONS:

Minimum Performance Specifications: Test Specification (TS) 445, Test Data Sheet (TDS) 445

QUALIFICATION STANDARD: RTCA DO-160F

CONDITIONS	SECTION	DESCRIPTION OF TEST
Temperature and Altitude	4	Category F3(Y)
Low Temperature	4.5.1	Operating Low Temp = -55C
High Temperature	4.5.2	Operating High Temp = +70C
In-Flight Loss of Cooling	4.5.5	Category Y = 300 minutes, +40C, 75%
Decompression	4.6.2	Altitude = +55,000 ft
Overpressure	4.6.3	-15,000 ft
Temperature Variation	5	Category S2
Humidity	6	Category B
Operational Shock and Crash Safety	7	Category B
Vibration	8	Category R, Curve C, C1 (RCC1)
Explosion	9	Category X
Waterproofness	10	Category X
Fluids	11	Category X
Sand and Dust	12	Category X
Fungus	13	Category X
Salt Spray	14	Category X
Magnetic Effect	15	Category Z
Power Input	16	Category X
Voltage Spike	17	Category X
Audio Frequency Conducted Susceptibility	18	Category X
Induced Signal Susceptibility	19	Category X
Radio Frequency Susceptibility	20	Category X
Emission of Radio Freq Energy	21	Category B
Lightning Induced Transient Susceptibility	22	Category X
Lightning Direct Effects	23	Category X
Icing	24	Category X
ESD	25	Category X
Flammability	26	Category X