

Revisions				
ECO	Rev.	Description	Date	Approved
	A	Revise dwg. Add Specifications. Top Level Assy. was 9015619.	2/26/04	NHK/ScH

Logo and company name have been changed in title block only. No functional or technical changes have been made. Revision remains unchanged.

SPECIFICATIONS:

- 1) TSO Compliance: TSO C129
Applicable Documents: RTCA DO-160C, DO-208
- 2) Current: 0.30 Amps typical.
- 3) Controls: NAV/GPS: Alternate action switch.
- 4) Annunciations and colors:
NAV: White
GPS: Green.
MSG: Amber.
WPT: Amber
APR: Green
HOLD: Green
- 5) Overall color shall be black.
- 6) Weight shall be 0.50 lbs.

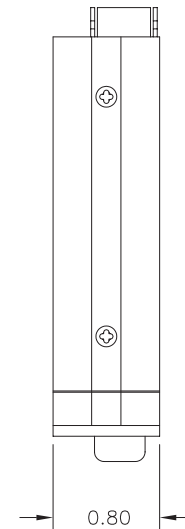
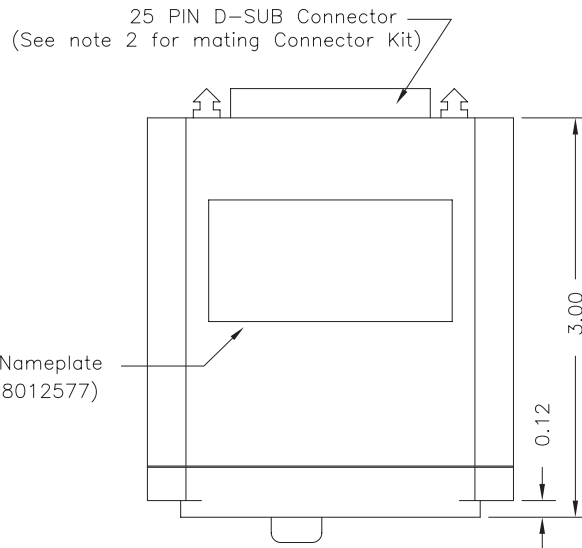

J1 (Connector Pinout)

NAV CIRCUIT BREAKER	1
GPS ANNUNCIATE INPUT	2
MSG ANNUNCIATE INPUT	3
WPT ANNUNCIATE INPUT	4
+5VDC DIMMER IN	5
ANNUNCIATOR PRESS TO TEST INPUT	7
APR ANNUNCIATE INPUT	9
HOLD ANNUNCIATE INPUT	10
ILS ENERGIZE	11
+14VDC AIRCRAFT POWER INPUT	13
NAV ANNUNCIATE INPUT	16
EXTERNAL RELAY ENERGIZE	24
POWER GROUND	25

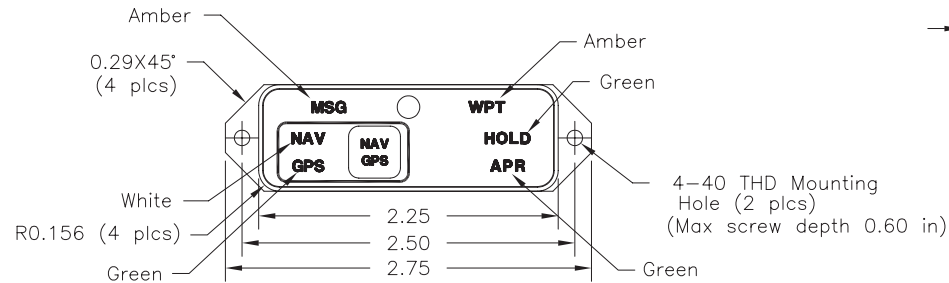

NOTES:

- 1) DO-160C ENV. CAT. F2-CA(MN)XXXXXXXXZBABATZXXX.
- 2) Mating Connector Kit: Positronic RD25F10JVLO (MCI P/N 7014517)

<small>UNLESS OTHERWISE SPECIFIED ALL DIMENSIONS ARE IN INCHES TOLERANCE: FRACTIONAL = ± 1/64 .XX = ± 0.15 .XXX = ± 0.05 .XXXX = ± 0.02 ANGULAR = ± 0.5° CONCENTRICITY: .005 TIR BREAK ALL SHARP EDGES THREADS PER MIL-5-7742</small>	DRAWN	D. TRAN	3/26/03		<small>TITLE:</small> GPS Annunciation Control Unit	<small>PART NUMBER:</small> MD41-1628(5V)
	APPROVED	ScH	3/26/03			
	<small>TOP LEVEL ASSY:</small> 9015633-()			<small>USED ON:</small>		
	<small>END ITEM:</small>			<small>SCALE:</small> None		
<small>SURFACE ROUGHNESS</small>	<small>CODE IDENT. NO.:</small> 59742		<small>DO NOT SCALE THIS DRAWING</small>		<small>SHEET</small> 1 of 1	

This document discloses proprietary information of Mid-Continent Instrument Co., Inc. It may be reproduced or disclosed only with written permission of Mid-Continent Instrument Co., Inc. and is not to be used in any way detrimental to the interests of Mid-Continent Instrument Co., Inc.