

SPECIFICATIONS:

- 1) TSO Compliance: TSO C129
Applicable Documents: RTCA DO-160C, DO-208
- 2) Operating Temperature Range: -55°C to +70°C
- 3) Humidity: 95% Non-Condensing.
- 4) Altitude Range: 0 to 55,000 ft.
- 5) Vibration: Cat. M and N.
- 6) Operational Shock: Rigid Mounting, 6G Operational
15G Crash Safety.
- 7) Current: 0.30 Amps typical.
- 8) Controls:
CDI: Momentary switch.
SUSP: Momentary switch.
- 9) Annunciations and colors:
GPS: White
NAV: Green
TERM: Green
APPR: Green
WPT: White
MSG: Amber
LOI: Amber
ALT: Amber
PTK: White
SUSP: White
- 10) Overall color shall be black.
- 11) Weight shall be 0.30 lbs.

25 PIN MALE
D-SUB CONNECTOR

TERM ANN.	15
MSG ANN.	6
LOI ANN.	9
WPT ANN.	8
ALT ANN.	10
APPR ANN.	3
NAV ANN.	2
GPS ANN.	1
GPS ANN. OUTPUT	14
NAV ANN. OUTPUT	16
LAMP TEST	7
SUSP MODE SELECT	12
PTK ANN.	11
SUSP ANN	24
CDI SOURCE SELECT	4
28VDC POWER	13
GROUND	25
28V DIMMER IN	5

NOTES:

- 1) Mating connector:
Mid-Continent P/N 7014517

Revisions				
ECO	Rev.	Description	Date	Approved

Logo and company name have been changed in title block only. No functional or technical changes have been made. Revision remains unchanged.

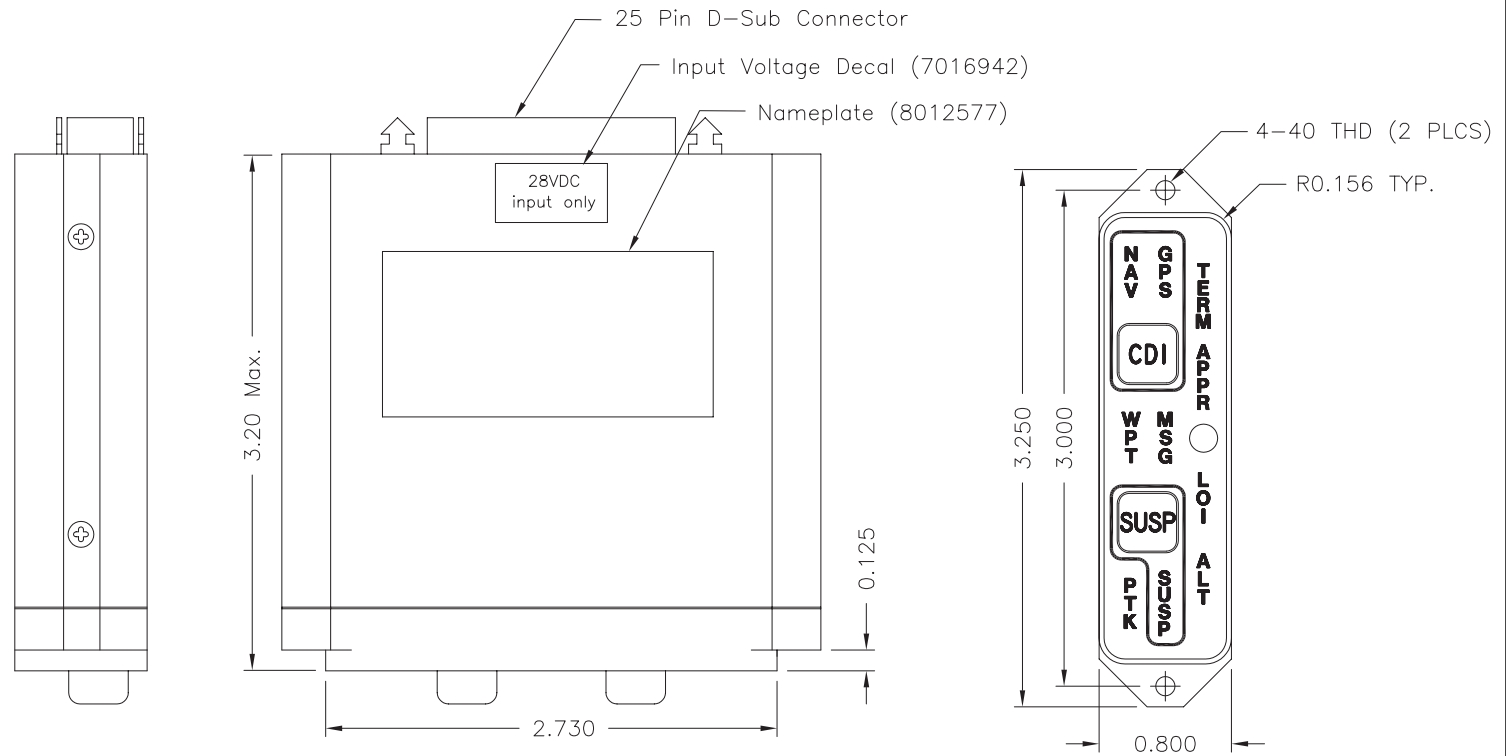

Vertical Mount

This document discloses proprietary information of Mid-Continent Instrument Co., Inc. It may be reproduced or disclosed only with written permission of Mid-Continent Instrument Co., Inc and is not to be used in any way detrimental to the interests of Mid-Continent Instrument Co., Inc.

<p>UNLESS OTHERWISE SPECIFIED ALL DIMENSIONS ARE IN INCHES TOLERANCE: FRACTIONAL = ± 1/64 .XX = ± .020 .XXX = ± .010 .XXXX = ± .002 ANGULAR = ± 0.5° CONCENTRICITY: .005 TIR BREAK ALL SHARP EDGES THREADS PER MIL-S-7742</p>	DRAWN	D. Tran	5/20/03		<p>TITLE: ANNUNCIATION CONTROL UNIT</p>	<p>PART NUMBER: MD41-1758</p>
	APPROVED	SdJ	6/6/03			
	TOP LEVEL ASSY:	9015664			<p>SCALE: None</p>	<p>SHEET 1 of 1</p>
	USED ON:					
END ITEM:						
SURFACE ROUGHNESS						
	CODE IDENT. NO.:	59742				