

Revisions				Date	Approved
ECO	Rev.	Description			
2448	A	7015662 Nameplate was 8012577.		8/9/01	JBR/ScH
2610	B	Move -324,-334,-338,-328(5V) & -338(5V) to separate dwgs. OBS/LEG was a momentary switch.		12/18/01	JBR/ScH

Logo and company name have been changed in title block only. No functional or technical changes have been made. Revision remains unchanged.

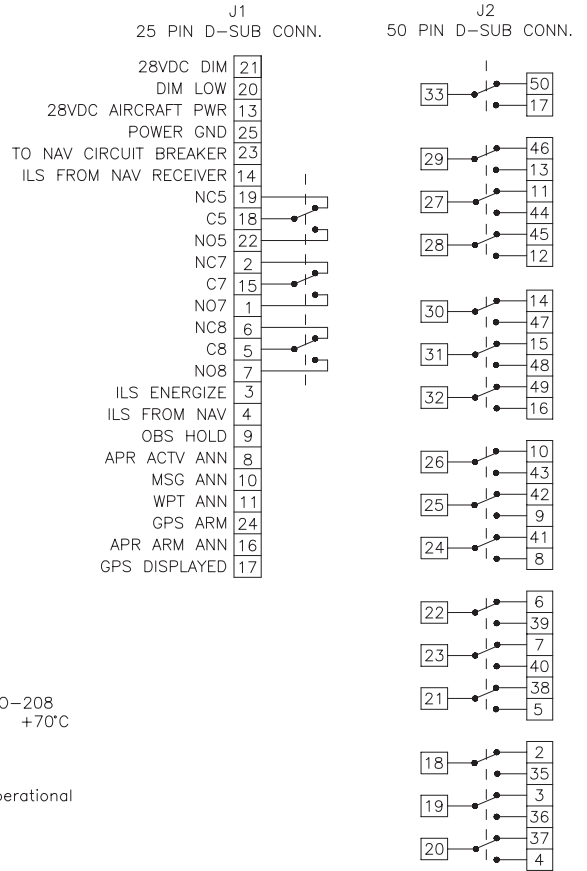
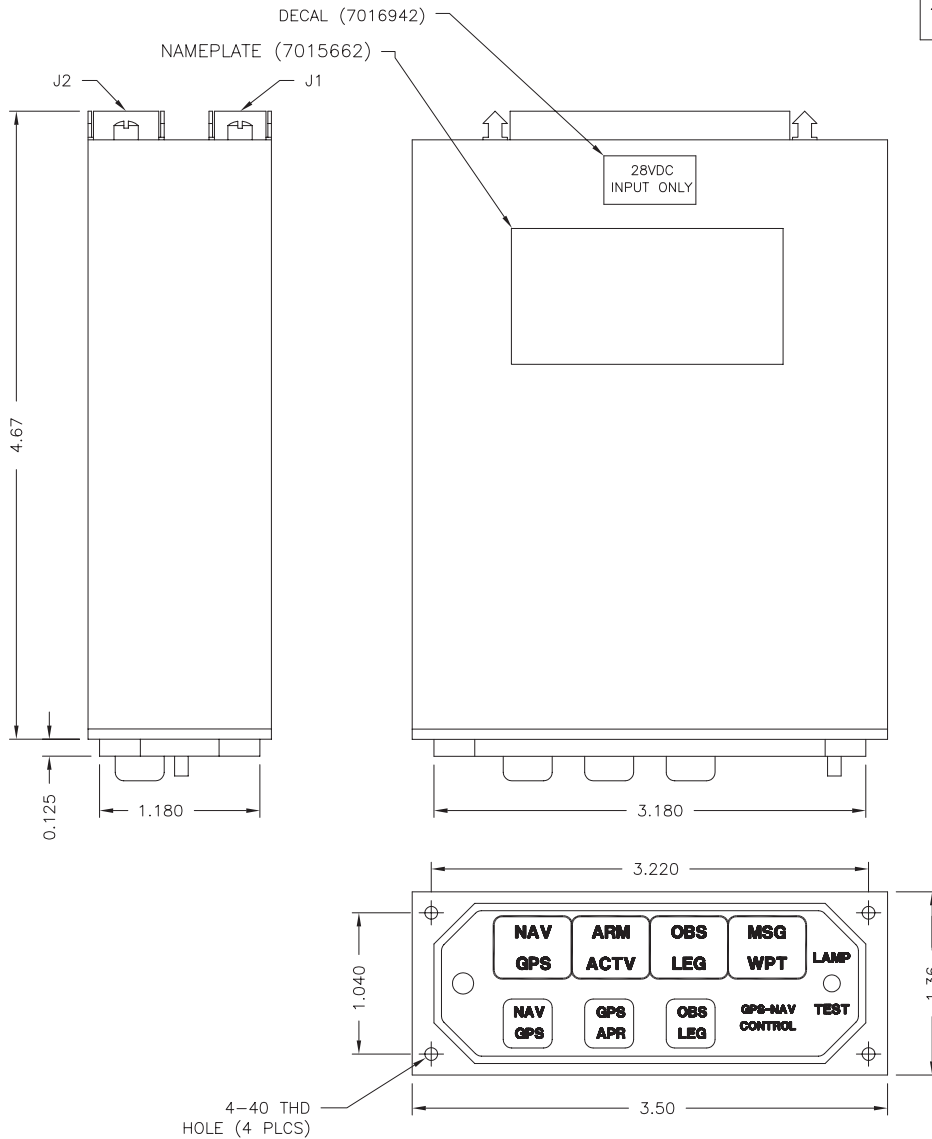

SPECIFICATIONS:

- TSO Compliance: TSO C129  
Applicable Documents: RTCA DO-160C, DO-208
- Operating Temperature Range: -55°C to +70°C
- Humidity: 95% Non-Condensing.
- Altitude Range: 0 to 55,000 ft.
- Vibration: Cat. M and N.
- Operational Shock: Rigid Mounting, 6G Operational 15G Crash Safety.
- Controls:  
NAV/GPS: Alternate action switch.  
GPS/APR: Momentary action switch.  
OBS/LEG: Alternate action switch.
- Annunciations and colors:  
NAV: white      OBS: white  
GPS: green      LEG: green  
ARM: white      MSG: amber  
ACTV: green      WPT: amber
- Overall color shall be black.
- Weight shall be 0.75 lbs.
- Electrical Specifications:  
MD41-328 (28VDC)      0.40 Amp.  
Relay Contact Current Rating      2 Amp. DC  
Available Relay Poles (SPDT)      19

(All relays shown in NAV position, for installation information refer to manual number 7016074).

- Notes:
- Mating connectors:  
For J1: 25 pin female Positronic P/N RD25F10JVLO (MCI P/N: 7014517).  
For J2: 50 pin female Positronic P/N RD50F10JVLO (MCI P/N: 7014509).

This document discloses proprietary information of Mid-Continent Instrument Co., Inc. It may be reproduced or disclosed only with written permission of Mid-Continent Instrument Co., Inc and is not to be used in any way detrimental to the interests of Mid-Continent Instrument Co., Inc.

UNLESS OTHERWISE SPECIFIED ALL DIMENSIONS ARE IN INCHES TOLERANCE: FRACTIONAL = ± 1/64 .XX = ± .015 .XXX = ± .005 .XXXX = ± .002 ANGULAR = ± 0.5° CONCENTRICITY: .005 TIR BREAK ALL SHARP EDGES THREADS PER MIL-S-7742 SURFACE ROUGHNESS _____ ✓	DRAWN	S. Hoang	1/23/01
	APPROVED	B. Barnes	1/23/01
	TOP LEVEL ASSY:	8012257-2	
	USED ON:		
	END ITEM:		
	CODE IDENT. NO.:	59742	

		TITLE: Annunciation Control Unit		PART NUMBER: MD41-328	
		SCALE: None	DO NOT SCALE THIS DRAWING		SHEET 1 of 1