

Revisions				Date	Approved
ECO	Rev.	Description			
2713	A	Add GPS/SEQ button.		4/10/02	JBR/Sch

Logo and company name have been changed in title block only. No functional or technical changes have been made. Revision remains unchanged.

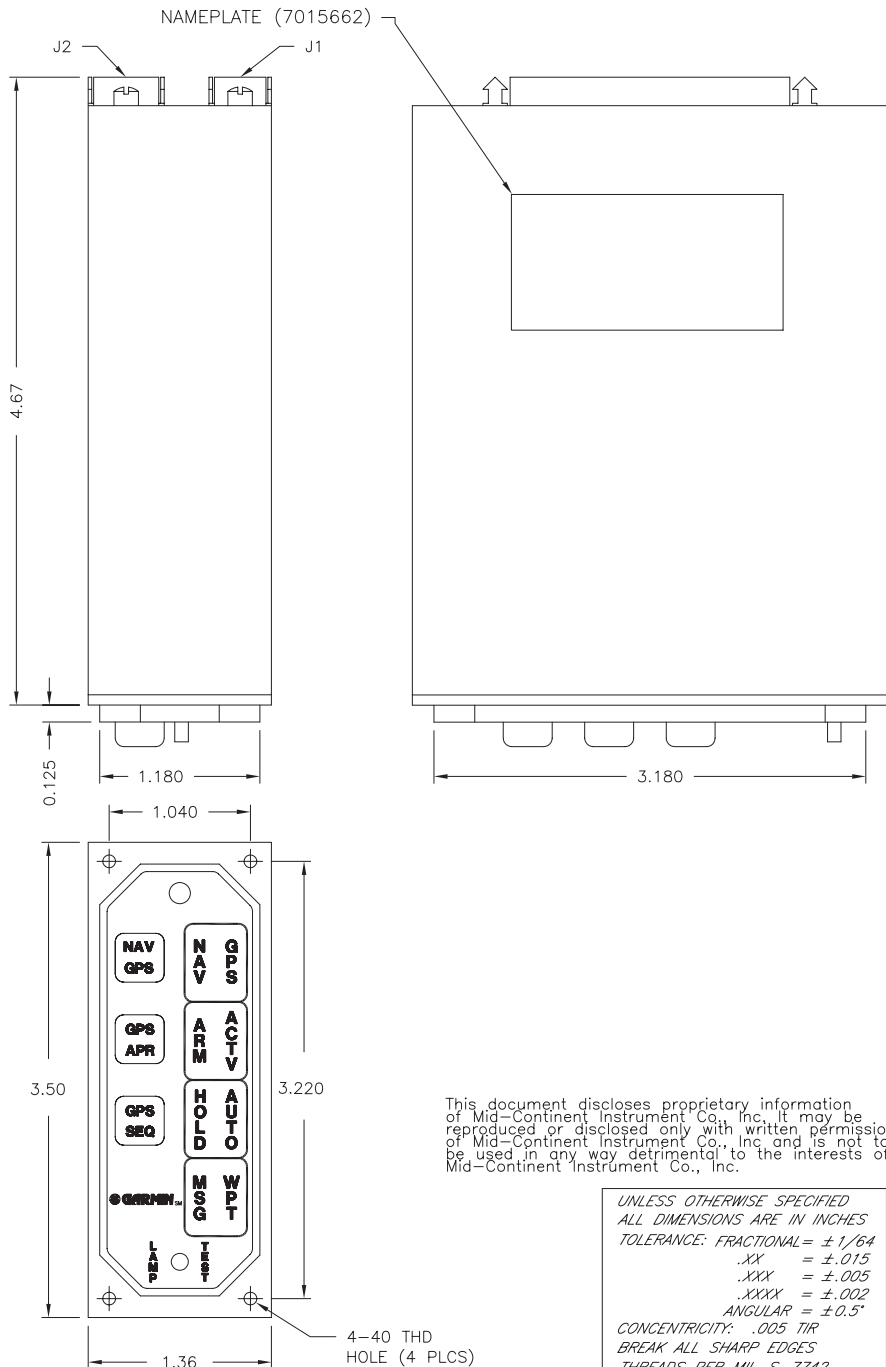

This document discloses proprietary information of Mid-Continent Instrument Co., Inc. It may be reproduced or disclosed only with written permission of Mid-Continent Instrument Co., Inc. and is not to be used in any way detrimental to the interests of Mid-Continent Instrument Co., Inc.

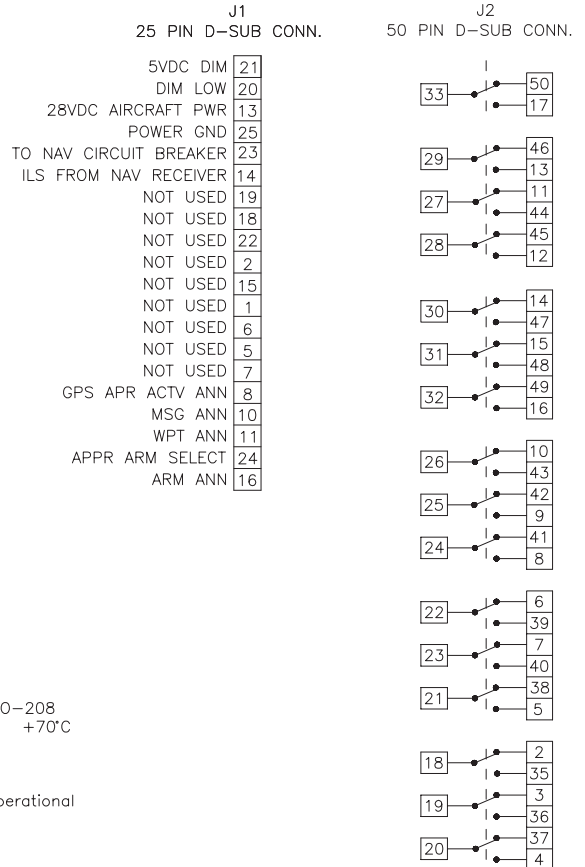

SPECIFICATIONS:

- TSO Compliance: TSO C129  
Applicable Documents: RTCA DO-160C, DO-208
- Operating Temperature Range: -55°C to +70°C
- Humidity: 95% Non-Condensing.
- Altitude Range: 0 to 55,000 ft.
- Vibration: Cat. M and N.
- Operational Shock: Rigid Mounting, 6G Operational 15G Crash Safety.
- Controls:  
NAV/GPS: Alternate action switch.  
GPS/APR: Momentary action switch.  
GPS/SEQ: Alternate action switch.
- Annunciations and colors:  
NAV: white      HOLD: amber  
GPS: green      AUTO: green  
ARM: white      MSG: amber  
ACTV: green      WPT: amber
- Overall color shall be black.
- Weight shall be 0.75 lbs.
- Electrical Specifications:  
MD41-438(5V)      0.40 Amp.  
Relay Contact Current Rating      2 Amp. DC  
Available Relay Poles (SPDT)      16

(All relays shown in NAV position, for installation information refer to manual number 7015555).

Notes:

- Mating connectors:  
For J1: 25 pin female Positronic P/N RD25F10JVL0 (MCI P/N: 7014517).  
For J2: 50 pin female Positronic P/N RD50F10JVL0 (MCI P/N: 7014509).

UNLESS OTHERWISE SPECIFIED  
ALL DIMENSIONS ARE IN INCHES  
TOLERANCE: FRACTIONAL = ± 1/64  
.XX = ± 0.015  
.XXX = ± 0.005  
.XXXX = ± 0.002  
ANGULAR = ± 0.5°  
CONCENTRICITY: .005 TIR  
BREAK ALL SHARP EDGES  
THREADS PER MIL-S-7742

DRAWN	J. Reed	2/14/02
APPROVED	Sch	2/14/02
TOP LEVEL ASSY:	8012553-10	
USED ON:		
END ITEM:		
CODE IDENT. NO.:	59742	

		TITLE: Annunciation Control Unit		PART NUMBER: MD41-438(5V)	
		SCALE: None	DO NOT SCALE THIS DRAWING		SHEET 1 of 1