

Revisions				
ECO	Rev.	Description	Date	Approved
3676	A	7017825 was 7016074. PTK ANN was WPT ANN	2/11/04	DDT/ScH

Logo and company name have been changed in title block only. No functional or technical changes have been made. Revision remains unchanged.

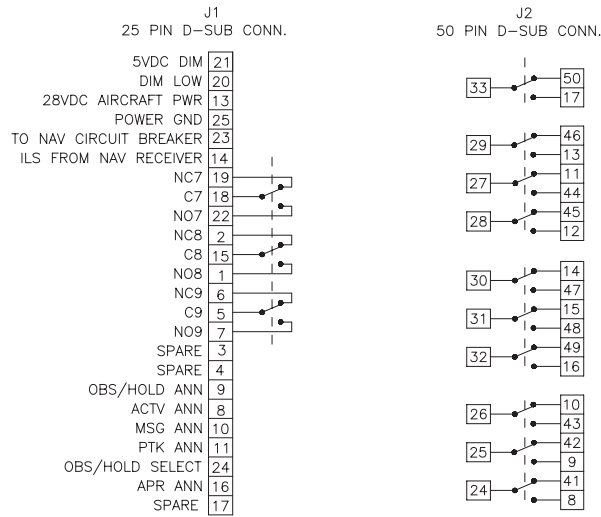

**SPECIFICATIONS:**

- 1) TSO Compliance: TSO C129  
Applicable Documents: RTCA DO-160C, DO-208
- 2) Operating Temperature Range: -55°C to +70°C
- 3) Humidity: 95% Non-Condensing.
- 4) Altitude Range: 0 to 55,000 ft.
- 5) Vibration: Cat. M and N.
- 6) Operational Shock: Rigid Mounting, 6G Operational  
15G Crash Safety.
- 7) Controls:  
NAV/GPS: Alternate action switch.  
GPS/SEQ: Momentary action switch.
- 8) Annunciations and colors:  
NAV: Green    OBS: White  
GPS: White    HLD: White  
MSG: Amber    APR: White  
PTK: White    ACTV: Green
- 9) Overall color shall be black.
- 10) Weight shall be 0.75 lbs.
- 11) Electrical Specifications:  
MD41-738 (5VDC), 0.40 Amp.  
Relay Contact Current Rating: 2 Amp. DC  
Available Relay Poles (SPDT): 19

(All relays shown in NAV position, for installation information refer to manual number 7017825).

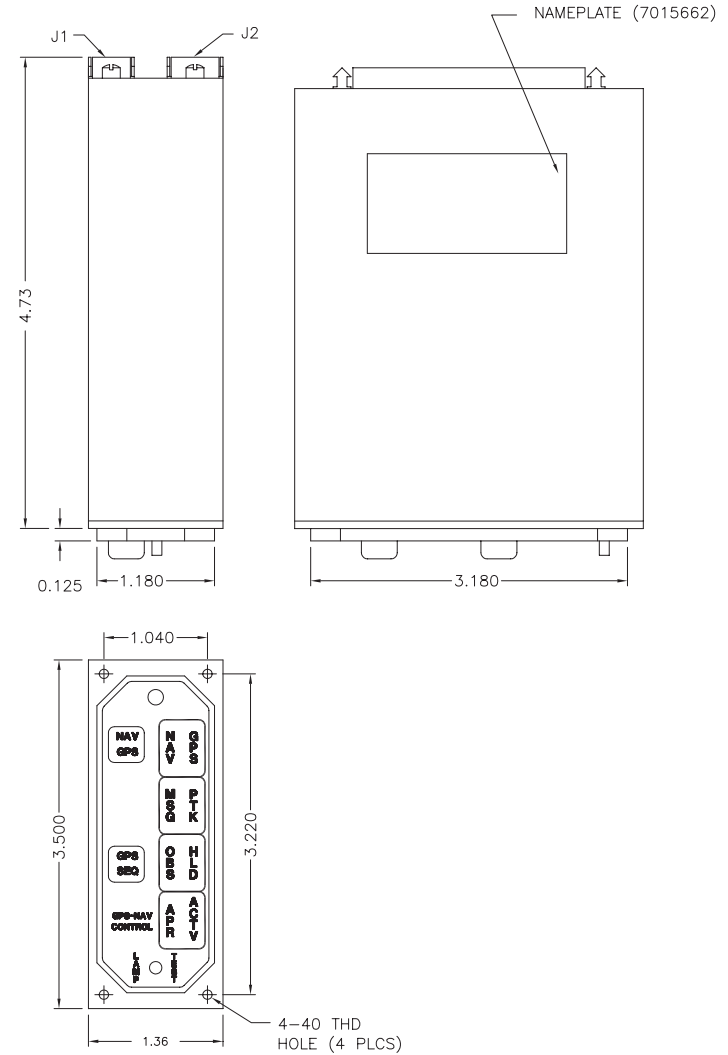

**Notes:**

- 1) Mating connectors:  
For J1: 25 pin female Positronic  
P/N RD25F10JVLO (MCI P/N: 7014517).  
For J2: 50 pin female Positronic  
P/N RD50F10JVLO (MCI P/N: 7014509).

This document discloses proprietary information of Mid-Continent Instrument Co., Inc. It may be reproduced or disclosed only with written permission of Mid-Continent Instrument Co., Inc and is not to be used in any way detrimental to the interests of Mid-Continent Instrument Co., Inc.

<p>UNLESS OTHERWISE SPECIFIED ALL DIMENSIONS ARE IN INCHES TOLERANCE: FRACTIONAL = ±1/64 .XX = ±.015 .XXX = ±.005 .XXXX = ±.002 ANGULAR = ±0.5° CONCENTRICITY: .005 TIR BREAK ALL SHARP EDGES THREADS PER MIL-5-7742</p> <p>SURFACE ROUGHNESS <input checked="" type="checkbox"/></p>	DRAWN	D. TRAN	3/11/03		<p>TITLE: Annunciation Control Unit</p>	<p>PART NUMBER: MD41-738(5V)</p>	
	APPROVED	ScH	10/15/03				<p>TOP LEVEL ASSY: 9015590</p>
	USED ON:				SCALE: None	DO NOT SCALE THIS DRAWING	SHEET 1 of 1
	END ITEM:						
	CODE IDENT. NO.:	59742					