

Revisions				Date	Approved
ECO	Rev.	Description			

Logo and company name have been changed in title block only. No functional or technical changes have been made. Revision remains unchanged.

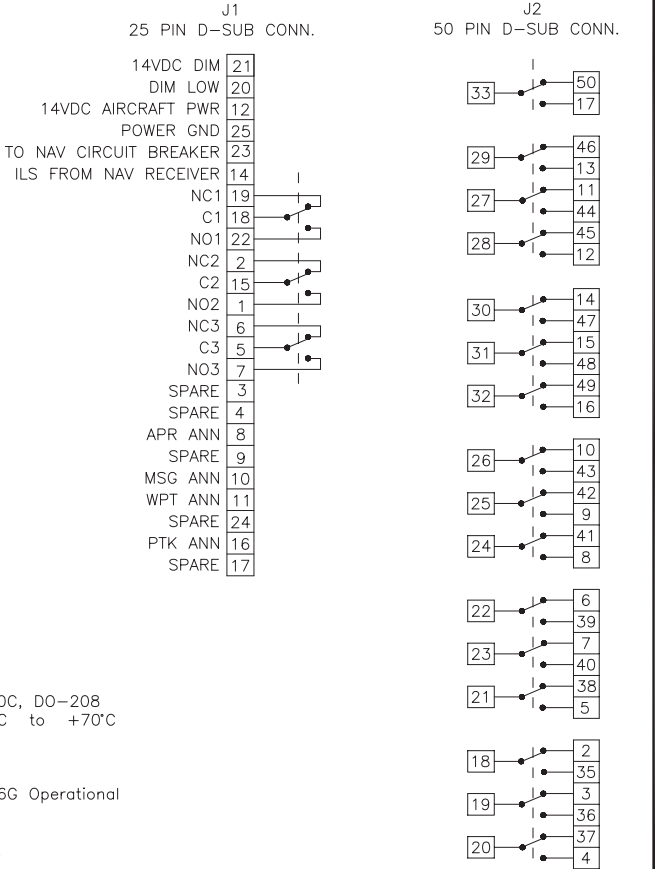
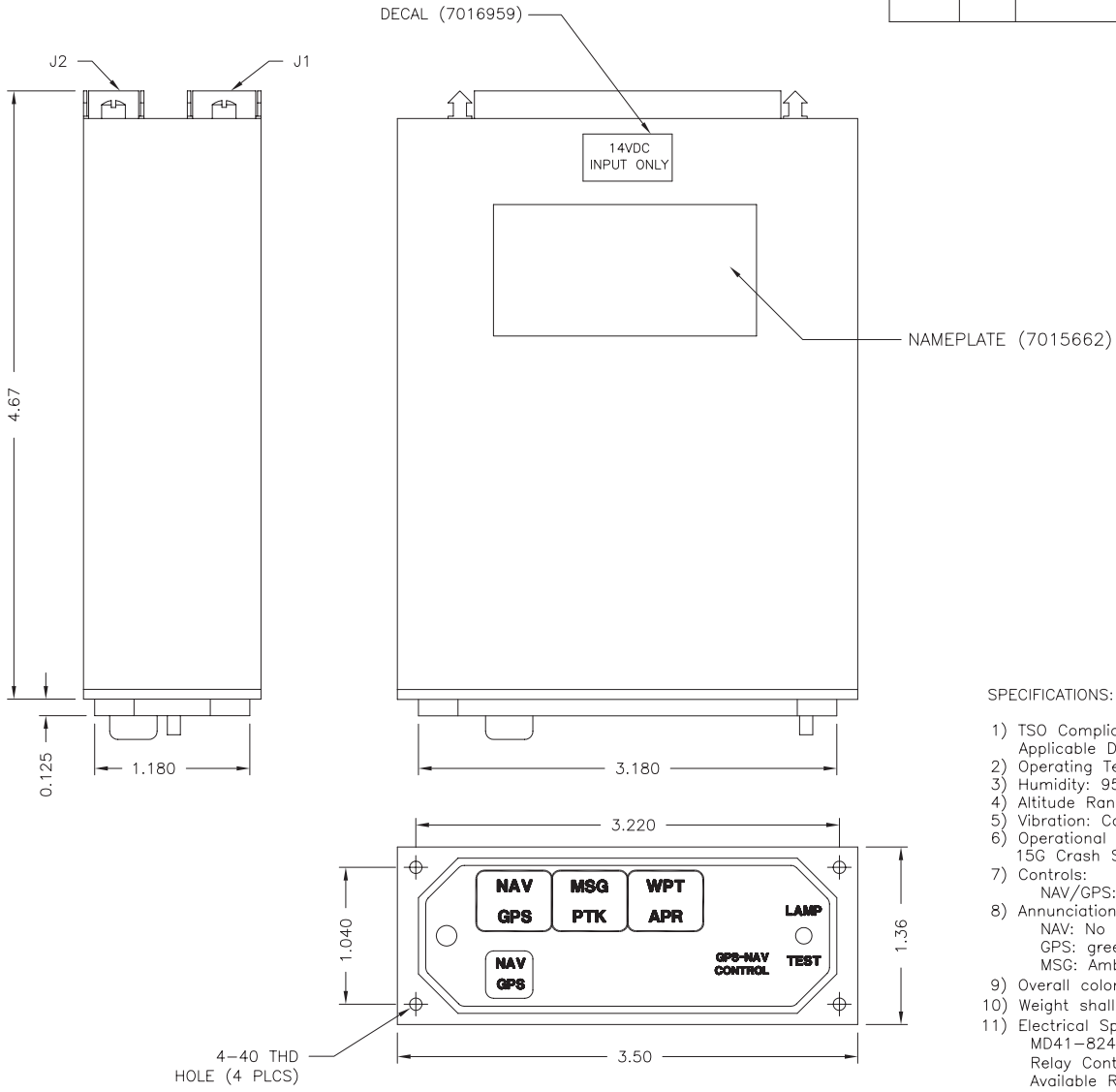

- SPECIFICATIONS:
- TSO Compliance: TSO C129  
Applicable Documents: RTCA DO-160C, DO-208
  - Operating Temperature Range: -55°C to +70°C
  - Humidity: 95% Non-Condensing.
  - Altitude Range: 0 to 55,000 ft.
  - Vibration: Cat. M and N.
  - Operational Shock: Rigid Mounting, 6G Operational 15G Crash Safety.
  - Controls:  
NAV/GPS: Alternate action switch.
  - Annunciations and colors:  
NAV: No color PTK: Amber  
GPS: green WPT: Amber  
MSG: Amber APR: Green
  - Overall color shall be black.
  - Weight shall be 0.75 lbs.
  - Electrical Specifications:  
MD41-824 (14VDC); 0.65Amp  
Relay Contact Current Rating; 2Amp. DC  
Available Relay Poles (SPDT); 19

Notes:  
1) Mating connectors:  
For J1: 25 pin female Positronic  
P/N RD25F10JVLO (MCI P/N: 7014517).  
For J2: 50 pin female Positronic  
P/N RD50F10JVLO (MCI P/N: 7014509).

UNLESS OTHERWISE SPECIFIED ALL DIMENSIONS ARE IN INCHES TOLERANCE: FRACTIONAL = ± 1/64 .XX = ± 0.015 .XXX = ± 0.005 .XXXX = ± 0.002 ANGULAR = ± 0.5° CONCENTRICITY: .005 TIR BREAK ALL SHARP EDGES THREADS PER MIL-S-7742 SURFACE ROUGHNESS _____ ✓	DRAWN	D. Tran	5/13/03
	APPROVED	SdN	5/13/03
	TOP LEVEL ASSY:	9015662	
	USED ON:		
	END ITEM:		
	CODE IDENT. NO.:	59742	

		PART NUMBER:
<b>MidContinent™</b> INSTRUMENTS+AVIONICS		MD41-824
TITLE:	Annunciation Control Unit	
SCALE:	None	
DO NOT SCALE THIS DRAWING		SHEET 1 of 1

This document discloses proprietary information of Mid-Continent Instrument Co., Inc. It may be reproduced or disclosed only with written permission of Mid-Continent Instrument Co., Inc. and is not to be used in any way detrimental to the interests of Mid-Continent Instrument Co., Inc.