

Revisions				Date	Approved
ECO	Rev.	Description			

Logo and company name have been changed in title block only. No functional or technical changes have been made. Revision remains unchanged.

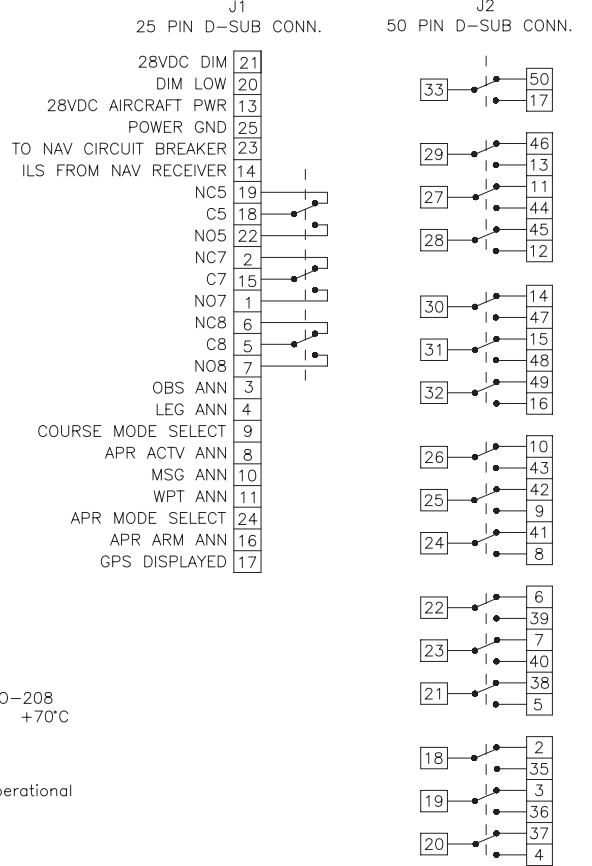
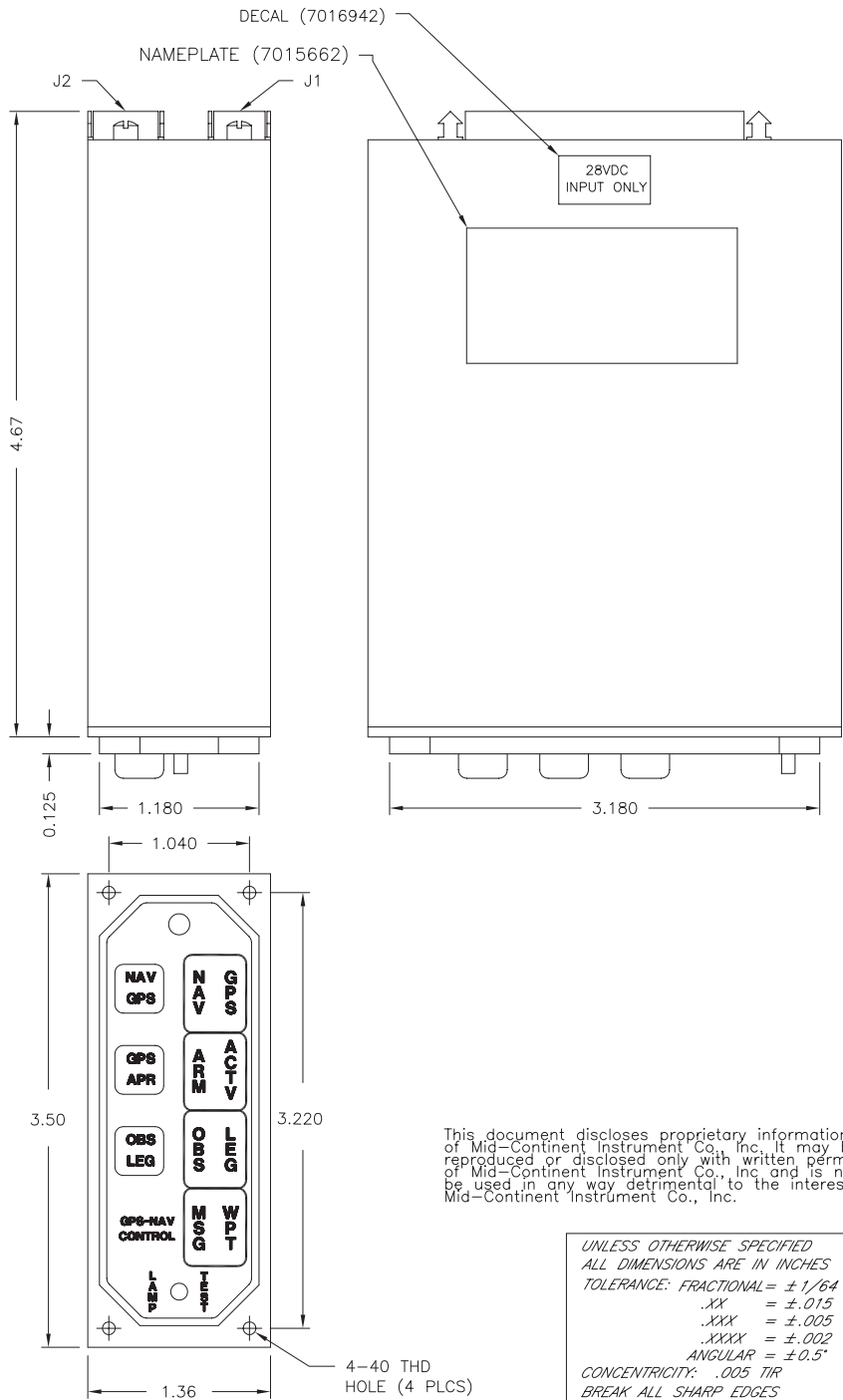

SPECIFICATIONS:

- TSO Compliance: TSO C129
Applicable Documents: RTCA DO-160C, DO-208
- Operating Temperature Range: -55°C to +70°C
- Humidity: 95% Non-Condensing.
- Altitude Range: 0 to 55,000 ft.
- Vibration: Cat. M and N.
- Operational Shock: Rigid Mounting, 6G Operational 15G Crash Safety.
- Controls:
NAV/GPS: Alternate action switch.
GPS/APR: Momentary action switch.
OBS/LEG: Alternate action switch.
- Annunciations and colors:
NAV: white OBS: white
GPS: green LEG: green
ARM: white MSG: amber
ACTV: green WPT: amber
- Overall color shall be black.
- Weight shall be 0.75 lbs.
- Electrical Specifications:
MD41-938 0.40 Amp.
Relay Contact Current Rating 2 Amp. DC
Available Relay Poles (SPDT) 19

(All relays shown in NAV position, for installation information refer to manual number 7018450).

- Notes:
- Mating connectors:
For J1: 25 pin female Positronic P/N RD25F10JVLO (MCI P/N: 7014517).
For J2: 50 pin female Positronic P/N RD50F10JVLO (MCI P/N: 7014509).

This document discloses proprietary information of Mid-Continent Instrument Co., Inc. it may be reproduced or disclosed only with written permission of Mid-Continent Instrument Co., Inc. and is not to be used in any way detrimental to the interests of Mid-Continent Instrument Co., Inc.

UNLESS OTHERWISE SPECIFIED ALL DIMENSIONS ARE IN INCHES TOLERANCE: FRACTIONAL = ± 1/64 .XX = ± .015 .XXX = ± .005 .XXXX = ± .002 ANGULAR = ± 0.5° CONCENTRICITY: .005 TIR BREAK ALL SHARP EDGES THREADS PER MIL-S-7742 SURFACE ROUGHNESS _____ ✓	DRAWN	J. Reed	1/3/02		TITLE: Annunciation Control Unit PART NUMBER: MD41-938
	APPROVED	ScN	1/3/02		
	TOP LEVEL ASSY:	8012257-11			
	USED ON:				
END ITEM:	CODE IDENT. NO.:	59742		SCALE: None	DO NOT SCALE THIS DRAWING
				SHEET 1 of 1	