



4200-10



4200 Series Mini Gyro 2-inch Electric Attitude Indicator

Manufactured by Mid-Continent Instruments and Avionics

THE 4200 SERIES MINI GYRO PROVIDES EMERGENCY ATTITUDE REFERENCE IN THE EVENT OF PRIMARY ATTITUDE FAILURE.

THE BEST VALUE IN A 2-INCH ELECTRIC ATTITUDE INDICATOR.

The 4200 Series Mini Gyro offers big features in a compact design. At half the cost of competing units, the Mini Gyro is the best value in a 2-inch electric attitude indicator.

An ideal standby instrument, this TSO-approved indicator has 10–32 volt DC operation and is a safe alternative to unreliable vacuum systems. It features unique LED lighting, selectable to 5, 14 or 28 volts.

The 4200 Series is standard equipment on many OEM aircraft and aftermarket certifications.

- A safe alternative to unreliable vacuum systems
- Single 4-pin connector installation
- Ideal standby artificial horizon in fixed-wing and helicopter applications
- Custom versions available to match existing instrument/EFIS displays
- 10–32 volt DC operation for use in 14 and 28 volt aircraft
- Standard equipment on many OEM aircraft
- Anti-reflective glass enhances visibility and reduces fatigue
- Long-life LED lighting, user selectable to 5, 14 or 28 volt input
- Use with optional MD420 or TS835 Emergency Power Supply to provide one hour or more of emergency attitude reference during an electrical failure
- FAA TSO-C4c certified and RTCA DO-160D/E qualified
- Designed and built in Wichita, Kansas, USA
- One-year limited warranty

4200 Series Mini Gyro

2-inch Electric Attitude Indicator

Manufactured by Mid-Continent Instruments and Avionics

SPECIFICATIONS

MTBF	2,500 hrs
Certification	FAA TSO-C4c RTCA DO-160D/E
Power Input	10-32 VDC 14 VDC input (1.4A max start, 0.51A running) 28 VDC input (0.6A max start, 0.25A running)
Dial	Rotating roll dial configuration, blue over brown Traditional or Delta wing symbolic airplane
Panel Tilt	Aircraft specific — calibrated at factory Specify exact tilt between 0° and 20° when ordering
Lighting	Internal LED lighting switchable to 5, 14 or 28 VDC input Wired through main connector
Glass	Special HEA anti-reflective coating
Weight	1.6 lbs
Length	5.94 inches
Mounting	Rear mount in standard 2" MS33638 panel cutout
Temperature Range	-30°C to +70°C (-22°F to +158°F)
Mating Connector	Mid-Continent P/N 9015514 (MS3116F8-4S)

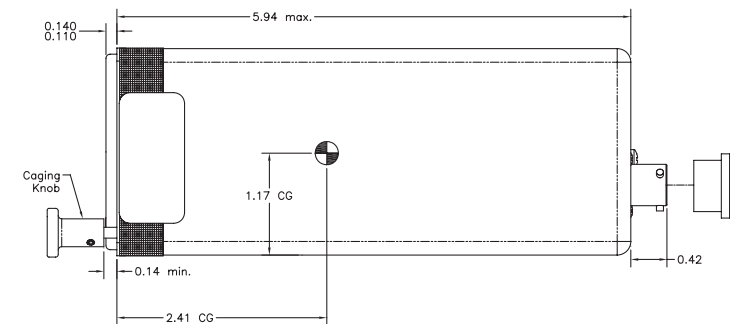
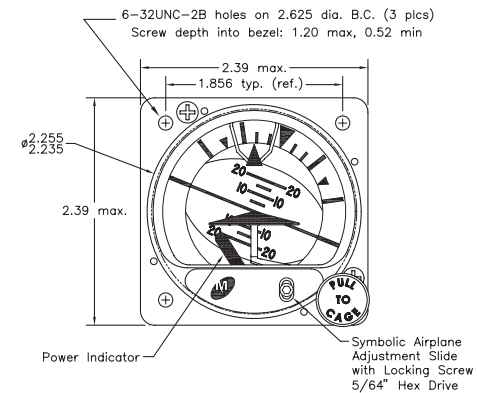

PART NUMBER	CONFIGURATION
4200-10	10-32V, Lighted, 0-20°
4200-11	10-32V, Lighted, 0-20°, Delta