

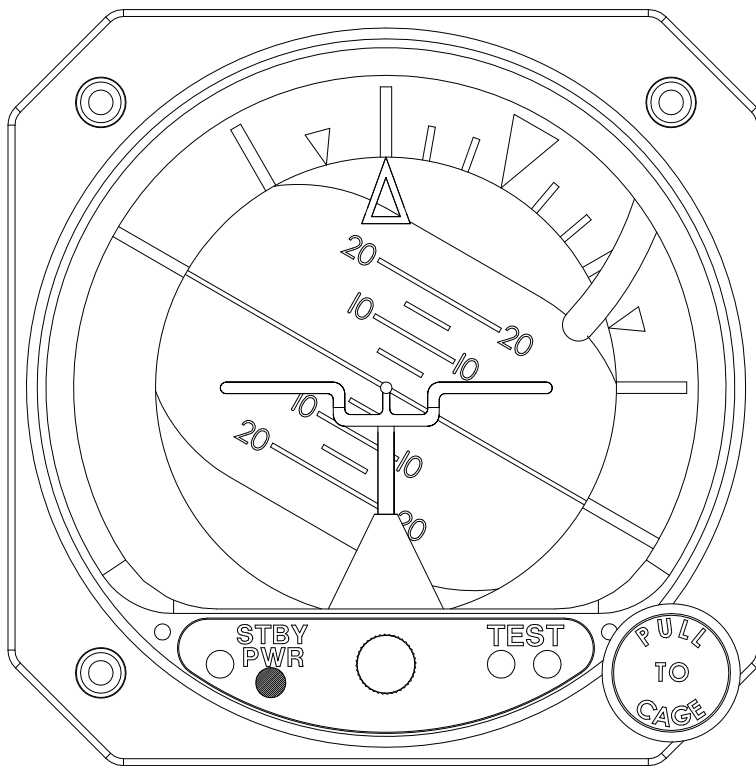

INSTALLATION MANUAL AND OPERATING INSTRUCTIONS

4300-XXX Series Electric Attitude Indicator With Battery Backup



Mid-Continent Instruments and Avionics
9400 E 34th Street N, Wichita, KS 67226 USA
Phone 316-630-0101 • Fax 316-630-0723

Manual Number 9015762
Rev. L, May 4, 2018

FOREWORD

This manual provides information intended for use by persons who, in accordance with current regulatory requirements, are qualified to install this equipment. If further information is required, please contact:

Mid-Continent Instruments and Avionics
Attn: Customer Service Dept.
9400 E. 34th ST North
Wichita, KS 67226 USA
Phone 316-630-0101 Fax 316-630-0723

We welcome your comments concerning this manual. Although every effort has been made to keep it free of errors, some may occur. When reporting a specific problem, please describe it briefly and include the manual part number, the paragraph/figure/table number, and the page number. Send your comments to:

Mid-Continent Instruments and Avionics
Attn: Technical Publications
9400 E. 34th ST North
Wichita, KS 67226 USA
Phone 316-630-0101 Fax 316-630-0723
info@mcico.com
www.mcico.com

© Copyright 2003
Mid-Continent Instruments and Avionics

Table of Contents

| | | Page |
|-------------------|---|-------------|
| Section 1 | General Description | 5 |
| 1.1 | Purpose of Equipment | 5 |
| 1.2 | Physical Description | 5 |
| 1.3 | Functional Description | 5 |
| 1.4 | Gyro Warning Flag | 6 |
| 1.5 | Options and Configurations | 6 |
| 1.6 | Specifications | 6 |
| Section 2 | Installation | 11 |
| 2.1 | General | 11 |
| 2.2 | Pre-Installation Inspection | 11 |
| 2.2.1 | Modifications | 12 |
| 2.3 | Parts | 13 |
| 2.3.1 | Included Parts | 13 |
| 2.3.2 | Installer Supplied Parts | 13 |
| 2.3.3 | Additional Optional Parts | 13 |
| 2.4 | Equipment Location | 13 |
| 2.5 | Installation | 14 |
| 2.6 | Continued Airworthiness | 15 |
| 2.6.1 | Battery | 15 |
| 2.6.2 | Attitude Indicator | 17 |
| Section 3 | Operation | 21 |
| 3.1 | General | 21 |
| 3.2 | Starting Procedures | 21 |
| 3.3 | In-Flight Procedures | 21 |
| 3.4 | Dynamic Errors | 21 |
| 3.5 | Standby Battery Operation | 22 |
| 3.6 | Equipment Limitations | 24 |
| Figure No. | List of Illustrations | |
| 1.1 | Display Configurations | 8 |
| 1.2 | Typical Indicator Display Detail | 10 |
| 2.1 | Nameplate and Mod Status | 12 |
| 2.2 | Standby battery Mod 0 nameplate | 16 |
| 2.3 | Standby battery Mod 1 nameplate | 16 |
| 2.4 | Outline Drawing | 18 |
| 2.5 | Rear-Mount Cutout Dimensions | 19 |
| 2.6 | Front-Mount Cutout Dimensions | 19 |
| 2.7 | Remote Mount Standby Battery Option with 9015671 Kit | 20 |
| 3.1 | Nominal Battery Discharge Rate at 20°C | 23 |
| 3.2 | Effect of Low Temperature on Battery Capacity | 24 |
| 3.3 | Life Characteristics in Standby Use | 24 |
| Table No. | List of Tables | |
| 1.1 | Options Table | 6 |
| 1.2 | Physical Characteristics | 6 |
| 1.3 | Performance | 7 |
| 1.4 | Light Tray Assembly Options | 7 |

Revision Detail

| <u>Date</u> | <u>Detail</u> |
|-------------|---|
| 10/01/03 | Complete issue |
| 11/04/03 | Revise text for improved short battery test. Add text to Section 2.6.2.B for P/N 36029 battery charger. |
| 05/25/04 | Update display configurations Figure 1.1, update connector pinout: Lighting (No polarity), revise currents in table 1.3, add bezel dims to panel cutouts, add DO-160D environmental test qualification in Table 1.2. |
| 09/15/04 | Revise section 2.6. Update DO-160D statement in section 1.6 from A2... to C1... for 35K altitude. |
| 03/28/05 | Add Special HIRF Considerations paragraph to section 2.5. Update DO-160D statement in section 1.6 from [RR]... to [WW]... |
| 01/04/06 | Add section 2.6.1D.2 regarding automatic capacity test. |
| 04/30/07 | Delete -40X single voltage versions. |
| 12/13/07 | Update DO-160 qualification in section 1.6 from [WW] to [WF]... and from [A3C3]... to [A3H33]. Remove paragraph pertaining to Special HIRF Considerations in section 2.5. Note: This change is incorporated only on units identified as Mod Status 4 as indicated on the unit nameplate. |
| 05/26/09 | Change 4300-4XX to 4300-XXX with Battery Backup to include OEM specific versions. |
| 09/01/09 | Remove first paragraph in section 3.6 stating that Indicator is not to be used as a reference for aerobatic flight. Update DO-160 qualification in section 1.6 from [(SBM)(RBB1)]... to ...[(SBM)(RBB1)(P)]... |
| 04/23/18 | Added references to Mod 1, Ni-MH battery. Mod 0 is lead acid. |
| 05/04/18 | Revised section 2.2.1, moved battery nameplate to section 2.6.1E |

Section 1: General Description

1.1 Purpose of Equipment

The Model 4300-XXX Electric Attitude Indicator with Battery Backup incorporates a moving display that simulates the earth's horizon and provides the pilot with a real time visual indication of the aircraft pitch and roll attitude relative to the indicator symbolic airplane.

The instrument can function as a primary or standby indicator with special configurations available to match existing systems or electronic flight displays. In the event aircraft electrical power is lost, the indicator will switch to an internal backup power source (rechargeable battery) to permit continued operation of the indicator. Panel tilt, lighting color/voltage, non-trimmable knob cover, front mount adapter plates and a slip indicator are available as options.

1.2 Physical Description

The 4300-XXX Electric Attitude Indicator with Battery Backup incorporates pitch and roll displays that are mechanically linked to a spinning mass gyroscope. The horizon bar moves behind the symbolic airplane. Precession error is corrected by the 4300's erection system or by pulling the "PULL TO CAGE" knob. If the gyro motor is not receiving sufficient power to operate, a warning flag drops into view. This will normally occur only if the unit is turned off or after the internal standby battery is exhausted.

1.3 Functional Description

Model 4300-XXX Electric Attitude Indicators employ an efficient electrically driven internal vertical gyroscope assembly incorporating a special air erection mechanism. This mechanism simultaneously erects the pitch and roll axes of the gyroscope. Movement of the aircraft generates a reaction of the display that simulates the visual reference seen by the pilot when looking outside at the earth's true horizon line.

The 4300-XXX Electric Attitude Indicator with Battery Backup offers the unique feature of a self-contained standby power source. Advances in the design of this gyro system allow it to operate for about one hour after main input power is lost, depending on the battery condition at the time of power failure.

Any time aircraft power is absent, with the unit in either power loss warning mode or turned off, pushing the STBY PWR button will put the unit into the standby power mode. The instrument will run from standby power until the internal battery is exhausted. If the unit is already running on standby power (internal battery), pushing the STBY PWR button will turn the unit off completely. Pushing the STBY PWR button again will restore unit operation to standby power. Restoring aircraft power will clear any standby power mode and automatically resume standby battery charging.

The indicator will operate on an input voltage of 10 to 32 volts. An integral lighting system featuring a user replaceable light tray assembly operates from the aircraft lighting bus and is available in 5V, 14V, or 28V versions (dependent on configuration). In standby power operation, low intensity LED dial lighting is automatically turned on to provide nighttime visibility.

The internal battery is designed for emergency use only. Frequent use, extended discharging, extended lack of charging, misuse and age will require battery replacement. Replacement can be done in the field with or without removal of the attitude indicator. Do not operate this model without the specified battery intact. Battery substitution, modification, misuse and lack of

Mid-Continent Instruments and Avionics, Wichita, KS

specified maintenance will void all warranties and hold the manufacturer harmless from any and all claims or legal actions.

Refer to an FAA authorized maintenance facility for testing and maintenance of this instrument excluding battery or light tray replacement.

1.4 Gyro Warning Flag

A warning circuit monitors the electrical voltage used to power the gyro motor. When the Indicator is turned off, or after the internal battery is discharged, the gyro warning flag comes into view. Anytime aircraft power is lost, including normal end-of-flight power down, the unit will switch to the Power Loss Warning mode. If the STBY PWR button on the face of the instrument is not pushed before the end of the (nominal) one-minute timing period, the instrument will turn itself off and the gyro warning flag will appear. If the STBY PWR button is pushed, the gyro will run from standby power until the internal battery is exhausted before the gyro warning flag appears.

1.5 Options and Configurations

| Options Table | |
|------------------------|--|
| Panel Tilt Calibration | 0° to 20° |
| Lighting Voltage | 5V, 14V, or 28V (See Table 1.4) |
| Lighting Color | Blue/White, White, or Red (See Table 1.4) |
| Miscellaneous Parts: | Non-Trimable Symbolic Airplane Knob Cover (P/N 36022) |
| | Slip Indicator Kit (P/N 36023) |
| | Front Mount Kit: 3/32" thk (P/N 36028-1) or 1/2" thk (P/N 36027-1) |
| | Panel Wedges: 3° (P/N PW3R-3) or 4° (P/N PW3R-4) |
| | Mating Connector Kit (P/N 9015514) |
| | Remote Battery Mounting Kit (P/N 9015671) |
| | Replacement Standby Battery (P/N 9015607) |
| | Battery Charger (P/N 36029) |

Table 1.1

1.6. Specifications

| Physical Characteristics: | |
|----------------------------------|--|
| Qualification: | FAA-TSO-C4c |
| Environmental Qualification: | RTCA DO-160D Environmental Category C1BAB[(SBM)(RBB1)(P)]XXXXXXZZAZZ[WF]M[A3H33]XXA |
| Weight: | Mod 0: 3.7 pounds (2.7 pounds without battery) Mod 1: 3.3 pounds (2.7 pounds without battery) |
| Dimensions: | Length behind panel (not including mating connector) 6.6 inches long max. (battery not installed) 8.6 inches long max. (battery installed) 3.28 inches high maximum. 3.28 inches wide maximum. |
| Mating Connector: | MS3116F8-4S or equivalent (MCIA P/N 9015514) |
| Cover Glass | HEA (anti-reflective) coated. |
| Instrument Panel Mounting: | Rear mount. Front mount with adapter plate. |

Table 1.2

Mid-Continent Instruments and Avionics, Wichita, KS

| Performance: | |
|---------------------|---|
| Reliability | 7500 Hour Mean Time Between Failure (MTBF). |
| Initial Erection: | The "PULL TO CAGE" knob will erect the gyroscope to within 2.0° of case vertical in roll and pitch from any position at any time. |
| Final Erection: | The vertical gyroscope should be allowed to spin up for 3 minutes after rated power is applied and after initial erection. After 5 minutes the final erection accuracy of pitch and roll will be within 1° of vertical. |
| Erection Rate: | Gyroscope erects to local vertical in pitch and roll at 2.5° per minute minimum. |
| Warning Flag: | A gyro warning circuit provides for continuous monitoring of gyro voltage. If loss of gyro motor voltage occurs, the red warning flag will appear. See section 3.5 for battery operation. |
| Symbolic Airplane: | The adjustment range is $\pm 4^\circ$ minimum from the zero pitch position. |
| Power Consumption: | |
| Starting: | 1.8A maximum (at 14 VDC input) 0.9A maximum (at 28 VDC input) |
| Running: | Nominal 0.55A $\pm 15\%$ (at 14 VDC input) Nominal 0.27A $\pm 15\%$ (at 28 VDC input) |
| Lighting: | 2.5 watts maximum (for all models using 5V, 14V, or 28V lighting) |

Table 1.3

| Light Tray Assembly Options | | | |
|------------------------------------|-----------|------------|------------|
| P/N 9015640-() | | | |
| | 5V | 14V | 28V |
| Blue/White | -1 | -2 | -3 |
| White | -4 | -5 | -6 |
| Red | -7 | -8 | -9 |

Table 1.4

Mid-Continent Instruments and Avionics, Wichita, KS

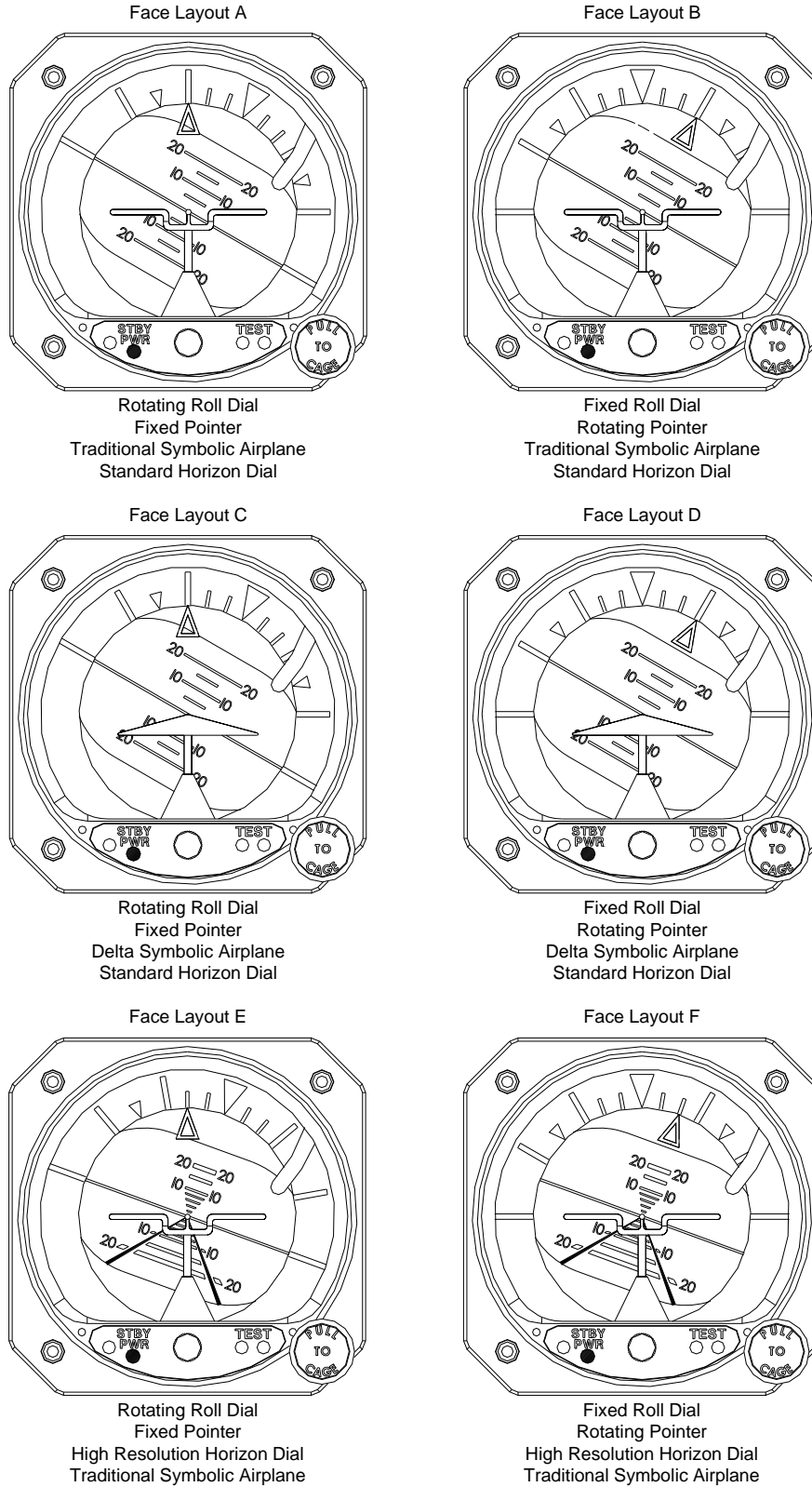
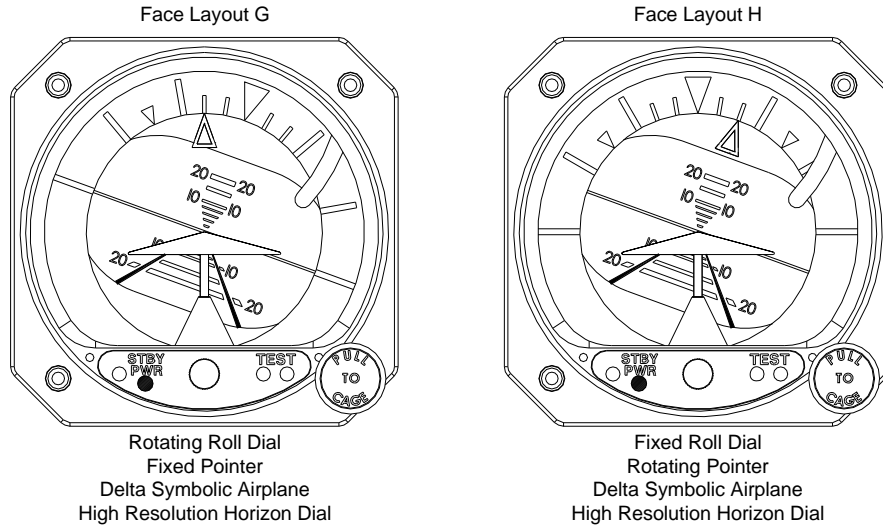

Figure 1.1
Display Configurations

Mid-Continent Instruments and Avionics, Wichita, KS



| Model Number | Input Voltage | Roll Dial | Horizon Dial | Symbolic Airplane | Face Layout |
|--------------|---------------|-----------|-----------------|-------------------|-------------|
| 4300-411 | 10 to 32 VDC | Rotating | Standard | Traditional | A |
| 4300-412 | 10 to 32 VDC | Fixed | Standard | Traditional | B |
| 4300-413 | 10 to 32 VDC | Rotating | Standard | Delta | C |
| 4300-414 | 10 to 32 VDC | Fixed | Standard | Delta | D |
| 4300-431 | 10 to 32 VDC | Rotating | High Resolution | Traditional | E |
| 4300-432 | 10 to 32 VDC | Fixed | High Resolution | Traditional | F |
| 4300-433 | 10 to 32 VDC | Rotating | High Resolution | Delta | G |
| 4300-434 | 10 to 32 VDC | Fixed | High Resolution | Delta | H |
| 4300-2XX | OEM Specific | | | | |

**Figure 1.1, Continued
Display Configurations**

- Roll Pointer:** A) Fixed roll pointer: Indicates aircraft roll displacement relative to a rotating roll dial.
 B) Rotating roll pointer: Indicates aircraft roll displacement relative to a fixed roll dial.
- Gyro Warning Flag:** If loss of operating voltage should occur, gyro warning flag will come into view.
- Display:** Lower area of display, when referenced to the symbolic airplane, indicates aircraft nose is below horizon or in a dive attitude. Upper area of display indicates aircraft nose is above horizon or in a climb attitude.
- Symbolic Airplane:** Indicates roll and pitch attitude relative to the horizon. The symbolic airplane can be moved (pitch only) using the symbolic airplane adjustment knob.
- Horizon Line:** Indicates earth horizon relative to aircraft pitch and roll attitude.
- Caging knob: (Manual Erection)** When pulled, manually erects the gyro vertical to the case orientation.
- Symbolic Airplane Adjustment Knob:** Used to adjust the symbolic airplane.

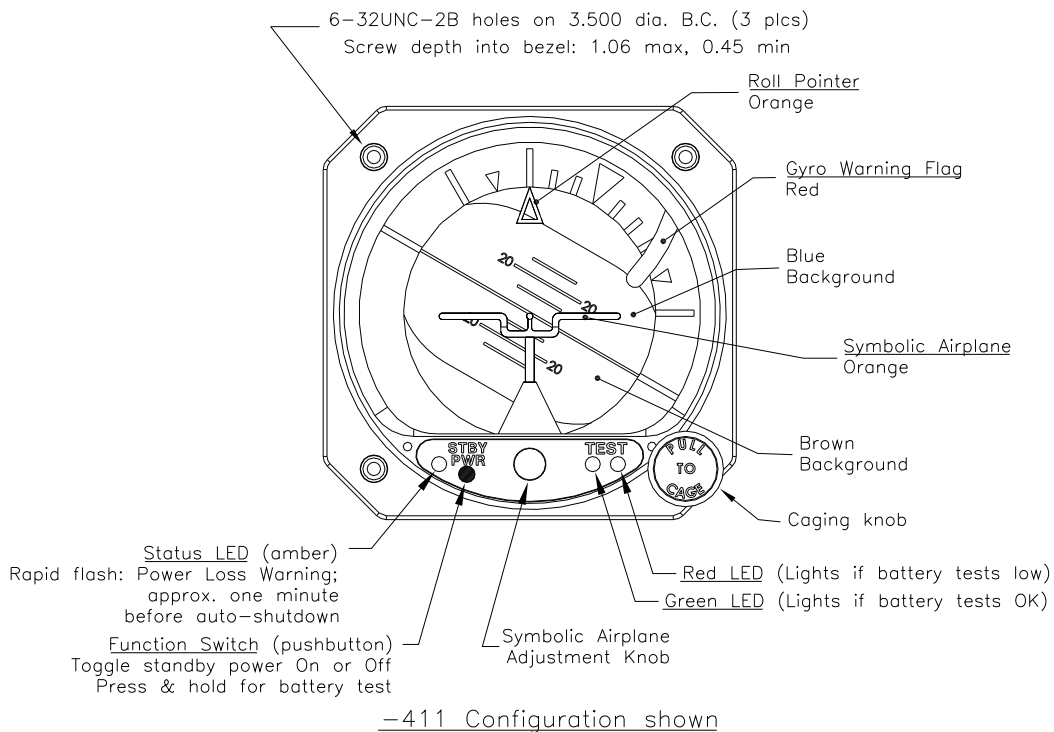

Typical Electric Attitude Indicator Display
 (Rotating Roll Dial, Fixed Roll Pointer, Traditional Wing Symbolic Airplane Shown)
Figure 1.2

Section 2: Installation

2.1 General

This section contains mounting, electrical connections and other information required for installation. After installation of cabling and before installation of the equipment, ensure that power is applied only to the pins specified in the interconnection diagram.

**CAUTION: GYROS ARE DELICATE INSTRUMENTS!
THE FOLLOWING PRECAUTIONS MUST BE OBSERVED!!**

- A. A high gyroscope failure rate can be directly related to rough or improper handling. Gyros are delicate and cannot withstand the shock of being dropped, jarred, or struck by pieces of equipment. Do not place gyros on any hard surface. Pad with generous foam. Handle like eggs!
- B. To prevent damage to a gyro, the instrument should be transported to and from the aircraft in its original shipping container. If this is impractical, the gyro should be hand-carried carefully in an upright position.
- C. A gyro should never be removed while it is spinning or running down. The instrument normally operates at high RPM and may take 10 minutes or longer to run down. If it is removed while running and tilted more than 20 degrees, the gyro can develop a gimbal lock. The gimbal will tumble and start to spin. If gimbal lock occurs while the rotor is turning, the gimbal may spin fast enough to damage the gimbal bearings, requiring an overhaul.
- D. A malfunctioning gyro should be handled with the same care given a new instrument. Most malfunctioning instruments can be repaired and returned to service. Using proper handling procedures during removal prevents additional damage and helps ensure possible reuse.

2.2 Pre-installation Inspection

- A. Unpacking: Carefully remove the attitude indicator from shipping container. The shipping container and packing materials should be retained for use should the attitude indicator require future shipment.
- B. Inspect for Damage: Inspect the shipping container and indicator for any signs of damage sustained in transit. If necessary, return attitude indicator to the factory using the original shipping container and packing materials. File any claim for damages with the carrier.
- C. **CAUTION: The unit is shipped with the battery cable disconnected to prevent inadvertent operation of the indicator during shipping.** If the cable was found connected when received, check the battery condition per section 2.6.3 and then reconnect the battery during instrument installation if it checks out ok. Remaining discharged for extended periods may permanently damage the battery pack.

Mid-Continent Instruments and Avionics, Wichita, KS

2.2.1 Modifications

Each 4300-XXX Series Electric Attitude Indicator with Battery Backup has a nameplate that identifies the manufacturer, part number, description, certification and technical specifications of the unit. It also includes the "MOD" or modification number representing notable changes in the hardware design of the unit. The following identifies each "MOD" or modification.

Modification (MOD) 0 is the initial release of the 4300-XXX Series Electric Attitude Indicator with Battery Backup and is identified on the nameplate by the lack of marking on the MOD numbers 1 through 9 (i.e. 1-9 are visible). All subsequent modifications are identified on the nameplate by the marking/blacking out of that particular MOD number (i.e. for MOD 1, the number 1 is not visible and 2-9 are visible – see figure 2.1 for examples).

For additional details regarding specific changes associated with each MOD status of the 4300-XXX Series Electric Attitude Indicator with Battery Backup, refer to the published Service Bulletins for the 4300-XXX.

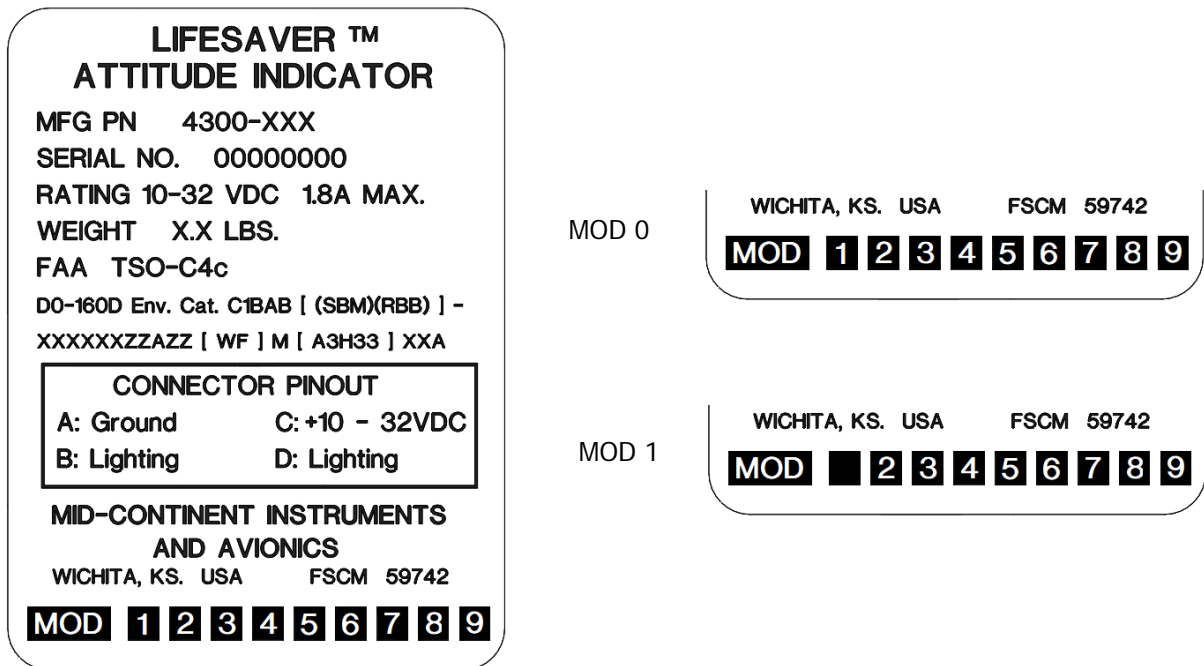

Figure 2.1 Nameplate and MOD status

2.3 Parts

2.3.1 Included Parts

- A. Model 4300-() Electric Attitude Indicator including Battery Pack (P/N 9015607).
- B. Mating Connector, MS3116F8-4S or equivalent (P/N 9015514).
- C. Installation Manual (P/N 9015762)

2.3.2 Installer Supplied Parts

Mounting Screw, 6-32UNC-2A. Three (3) required. (1" long screws are suggested for panel thickness between 0.05 and 0.19, but may not be optimum in some installations. The installer will need to determine what is correct for a particular installation.)

******CAUTION******

Do not exceed 1.06" screw depth into bezel!

2.3.3 Additional Parts that may be required

- A. Symbolic Airplane Adjustment Knob Cover Kit: (P/N 36022)
- B. Slip Indicator Kit (P/N 36023)
- C. Front Mount Kit: 3/32" thk (P/N 36028-1) or 1/2" thk (P/N 36027-1)
- D. Panel Wedges: 3" (P/N PW3R-3) or 4" (P/N PW3R-4)
- E. Remote Battery Mounting Kit (P/N 9015671)

2.4 Equipment Location

The attitude indicator should be located within the aircraft in accordance with the following considerations:

- A. The indicator is ideally located in the instrument panel directly in line with the pilot's normal line of sight. The "PULL TO CAGE" knob should be within easy reach. Installations that result in viewing angles in excess of 30 degrees may reduce display readability.
- B. Compare the space requirements of the indicator with the installation area being considered.
- C. The power cable should not run adjacent to heaters, engine exhausts, or other heat sources. Also, take care to route and tie the cable away from aircraft controls and cables.
- D. If remote mounting the standby battery, the cable length from the battery to the unit should be kept as short as practical using wire of 22 AWG minimum. 18 AWG wire is recommended for cable runs over 50 feet. Remote mounting the battery in a location subject to extreme temperature variations may dramatically shorten the emergency operation time available for the attitude indicator as well as the expected battery lifetime (Figures 3.2 and 3.3). For optimum battery performance it is recommended to mount the battery in a temperature controlled section of the aircraft.

2.5 Installation

NOTE: Before installing unit, verify the option label on the unit matches the aircraft requirements for instrument voltage, lighting voltage/color, and panel tilt.

Install the Electric Attitude Indicator within the aircraft in accordance with the aircraft manufacturer's instructions and the following steps:

- A. Refer to Figure 2.4 for installation dimensions and electrical information.
- B. Ensure the available instrument panel cutout meets the requirements of the indicator. See Figures 2.5 and 2.6 for details.
- C. If a remote mounted standby battery is preferred:
 - 1. Remove 4 screws mounting the standby battery to the rear of the indicator and remove the standby battery.
 - 2. Re-install the 4 screws into the rear of the indicator.
 - 3. Mount the standby battery in a protected location inside the aircraft using 9015671 kit, oriented at any angle from horizontal to vertical. If mounted vertically, cable side must be down as shown in Figure 2.7.
 - 4. Make an extension cable, 22 AWG minimum, using the connectors provided in 9015671 kit.

- D. Plug the standby battery cable into the rear of the Indicator.

NOTE: The cable is disconnected for shipping to prevent accidental activation and battery discharge in transit.

- E. The unit may start when the battery is connected. Momentarily push the STBY PWR button, twice if necessary, until the Red Gyro Warning flag shows. Continue the installation after the Gyro has spun down.
- F. Attach aircraft electrical system cable to the round 4-pin indicator connector and insert the indicator into the instrument panel cutout.
- G. Secure the indicator to the instrument panel using the screw sizes called out in the mounting instructions. Length of screws will be determined by aircraft instrument panel thickness. The aircraft manufacturer or the installation facility is responsible for supplying appropriate installation hardware.
- H. Apply the correct input power to the indicator.
- I. The Gyro Warning flag (red) will be out-of-view.
- J. Check to determine that indicator internal lighting is working correctly.
- K. After the unit has been powered for at least a 3-minute spin-up period, press and hold the STBY PWR button. A green light will illuminate under the word TEST, indicating the standby battery is functioning properly. If a red light illuminates, the standby battery will need to be charged for 1 hour before retesting. If the standby battery fails to pass the short battery capacity test after 1 hour charging, a full battery capacity test must be performed. See Section 2.6.1D.

2.6 Continued Airworthiness

2.6.1 Battery

A. The battery is designed to be a user replaceable item if desired. Recommended replacement interval for the standby battery (P/N 9015607) is 3 years because of diminished capacity (See Figures 3.2 and 3.3 for more information).



NOTE: The Mod 0 standby battery contains lead; the Mod 1 battery contains Ni-MH. Do not dispose of in local landfills or other environmentally sensitive areas.



NOTE: Recycle the battery in accordance with state and local regulations. For recycle locations visit www.rbr.com or call 1-800-8-BATTERY (1-800-822-8837)

B. In normal use, the 4300-XXX with Battery Backup supplies the proper charge voltage to maintain its battery at peak capacity, however, the battery will slowly self-discharge if the attitude indicator is left unused for long periods. The Mod 0 battery should be recharged at least every 3 months, or maintained on a float charger. The Mod 1 battery should be recharged at least once a year. In addition, self-discharge rates are directly related to the storage temperature. The higher the storage temperature the faster the self-discharge rate. Therefore, the battery should be periodically charged or removed from the installation and maintained on a charger.

C. If the 4300-XXX Electric Attitude Indicator with Battery Backup has not been operated for an extended period (more than 3 months) to keep the battery charged, the standby battery should be charged by one of the following methods.

1. Keep the battery plugged into the 4300 Electric Attitude Indicator. Run the unit overnight (approximately 15 hours) at the rated voltage.
2. Float Charging: (For Mod 0 battery only) Disconnect the battery from the indicator. Connect the battery to a constant voltage source (battery plug (pin 1) red wire = positive) of 20.4 to 20.6 VDC continuously. Float charging may take 24 hours or longer to charge a battery pack. The Mod 1 battery does not require float charging.
3. Routine Charging: (For Mod 0 and Mod 1 batteries) Disconnect the battery from the indicator. Connect the battery to a constant voltage source (battery plug pin 1 red wire = positive) of 21.6 to 22.1 VDC with a current limit of 0.1 ampere maximum. When the charging current drops to approximately 5mA, or 15 hours have elapsed, the battery is fully charged and should be disconnected. Leaving 21.6 to 22.1 VDC charge voltage on the battery for an extended time will degrade its life. If continuous maintenance of the charge is desired, perform routine charging at least once a year. For Mod 0 battery only, refer to step 2, Float Charging.

*****WARNING*****

For Mod 0 lead acid battery, out gassing and a rotten egg odor may occur due to prolonged high rate overcharging and may result in battery damage. MCIA recommends that the battery assembly be replaced if out gassing has occurred.

Mid-Continent Instruments and Avionics, Wichita, KS

4. MCIA Battery Charger/Tester P/N 36029 may be used. This Battery Charger/Tester will apply an initial charge, per step 3 above, and then automatically switch to maintain a float charge, per step 2 above, indefinitely after initial charging is complete.
- D. On at least an annual basis, as well as any time there may be a question about battery performance (life) a Full Capacity Test should be performed. To perform a Full Battery Capacity Test use one of the following methods.
 1. Manual.
 - a. Disconnect battery pack from the 4300 Attitude Indicator.
 - b. Ensure the battery is completely charged and at or near normal room temperatures (20-25°C). (Reference Section 2.6.1C)
 - c. Connect the battery to a load of 90 ohms (rated for 10 watts) for 60 minutes while monitoring the battery voltage level.
 - a) If the battery voltage is above 15.0 volts at the end of the 60-minute battery capacity test, the battery should be capable of continued use after recharging is complete.
 - b) If the battery voltage drops below 15.0 volts before the end of the 60-minute test period while under load, the battery pack is nearing the end of its service life and should be replaced.
 - d. Recharge the battery pack immediately.
 2. Automatic.
 - a. Use MCIA Battery Charger/Tester P/N 36029. When in the capacity test mode, this Charger/Tester will first charge the battery and then perform a timed discharge. (Pass = 60 minutes minimum) The unit will then automatically switch to the charge/float mode to maintain the standby battery at full charge.

******WARNING******

The Mod 0 battery may be permanently damaged if it is left in a discharged state. Recharge a discharged battery as soon as possible and maintain with a float charge for maximum battery life.

Mid-Continent Instruments and Avionics, Wichita, KS

- E. Each standby battery (9015607-()) has a nameplate that identifies the manufacturer, part number, description, and technical specification of the standby battery.

Modification (MOD) 0 is the initial release of the standby battery containing lead acid and is identified without a modification descriptor, reference Figure 2.2.

Modification (MOD) 1 is the revised release of the standby battery containing Nickel Metal Hydride and is identified with a modification descriptor with the number 1 block blacked out, reference Figure 2.3.

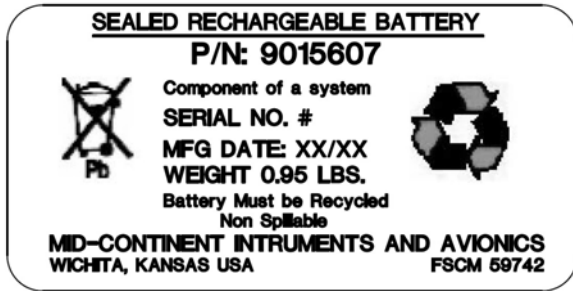

Figure 2.2 Standby battery Mod 0 nameplate



Figure 2.3 Standby battery Mod 1 nameplate

2.6.2 ATTITUDE INDICATOR

No periodic scheduled maintenance or calibration is necessary for continued airworthiness of the 4300 series Electric Attitude Indicator. If the unit fails to perform to specifications, it must be removed and serviced by a qualified service facility.

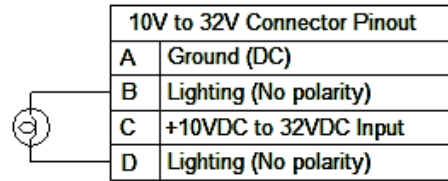
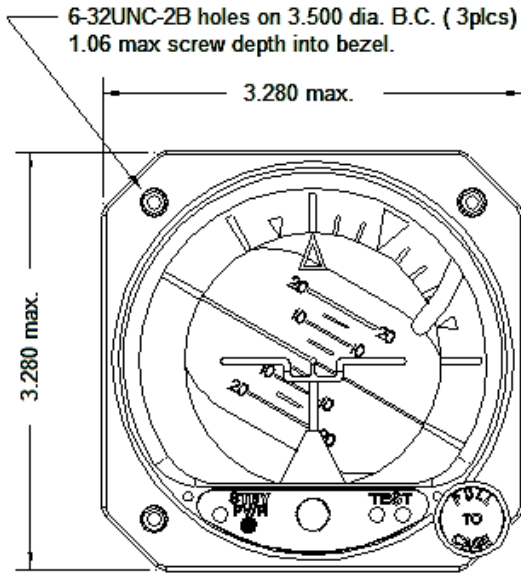

-411 Configuration shown

Note:

- 1) Recommended Circuit Breaker: 2 Amp for 14VDC aircraft and 1 Amp for 28VDC aircraft.
- 2) Recommended wire gauge: 22 AWG minimum.

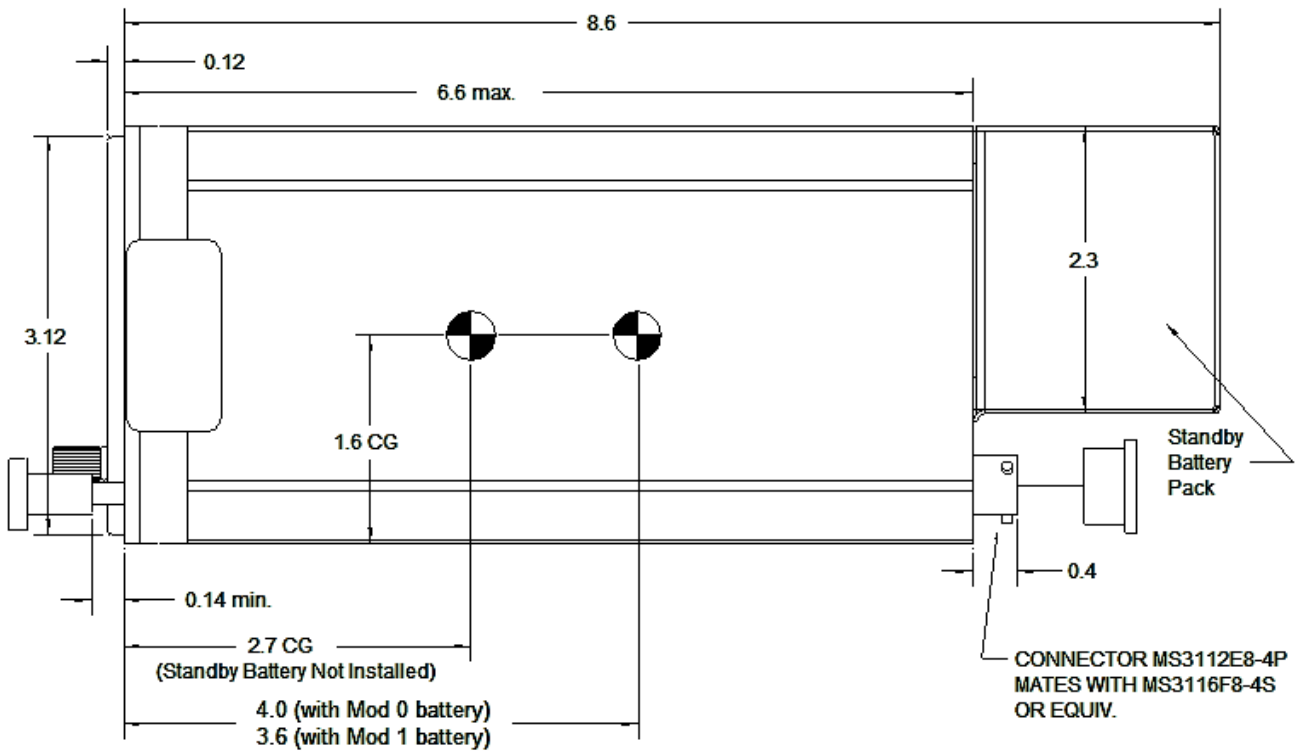

Figure 2.4 Outline Drawing

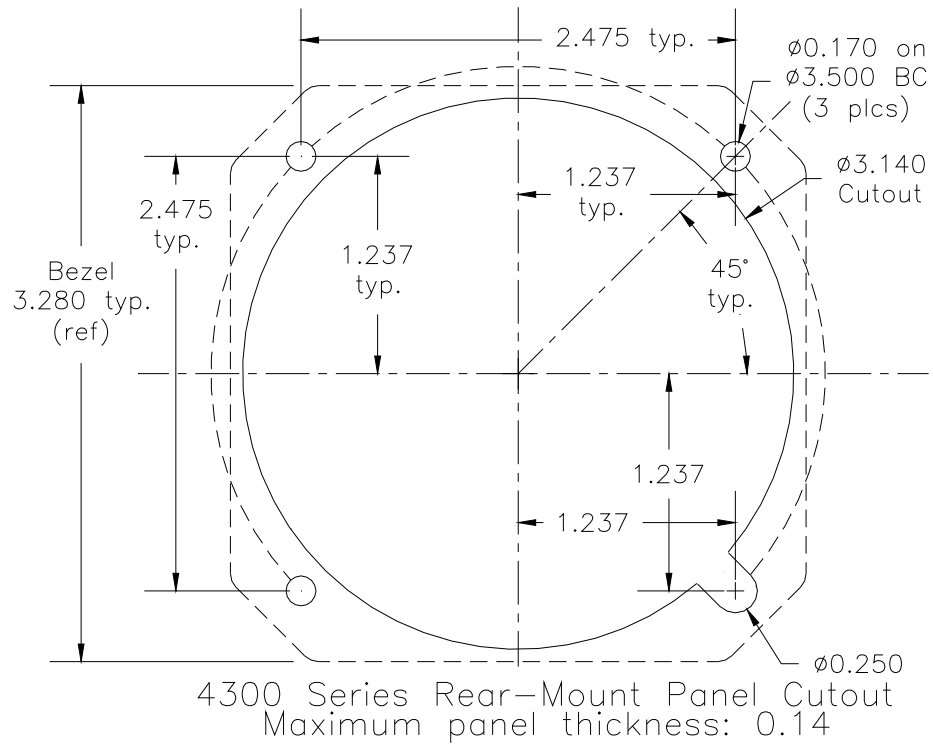

Figure 2.5: Panel Cutout Dimensions

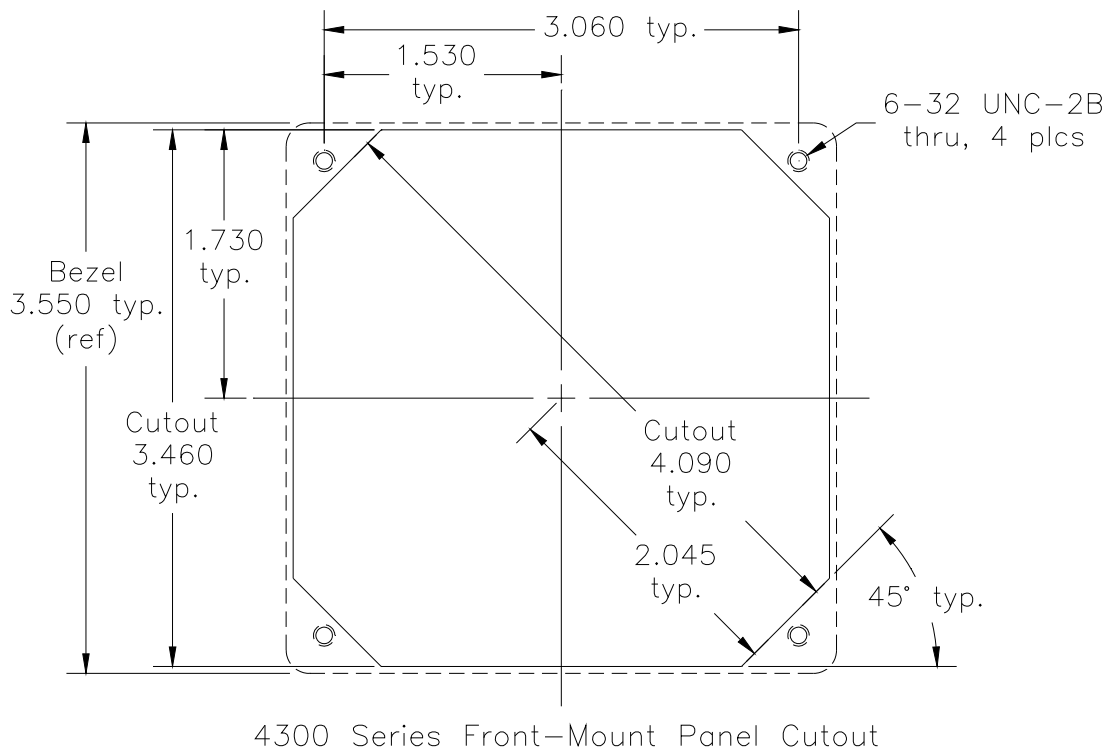

Figure 2.6: Front Mount Panel Cutout Dimensions

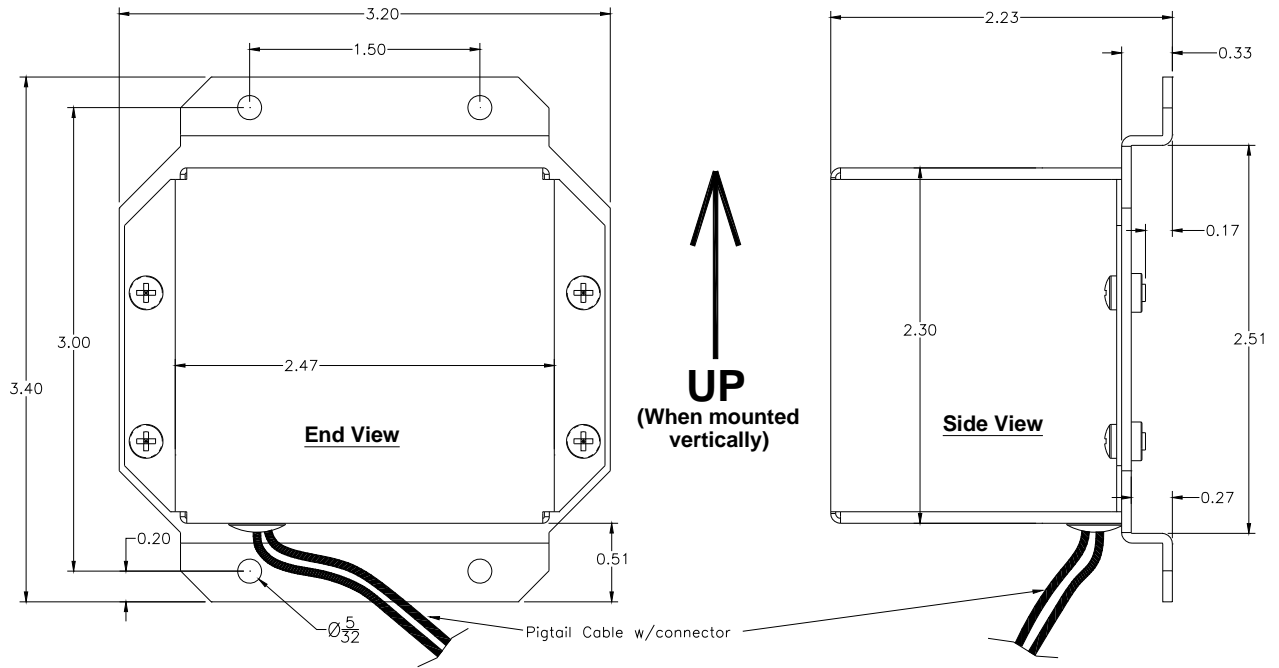

Figure 2.7: Remote Mount Standby Battery Option, using 9015671 Kit

Contents of Standby Battery Remote Mount Kit:

| <u>Part Number</u> | <u>Description</u> | <u>Qty</u> |
|--------------------|------------------------------------|------------|
| 7016975 | Crimp Pin | (2) |
| 7016983 | Connector Housing Cap | (1) |
| 7017676 | Screw, 4-40x3/16 Pan Head Phillips | (4) |
| 7018328 | Contact Socket | (2) |
| 7018336 | Connector Housing Plug | (1) |
| 9015725 | Battery Mount Plate | (1) |

Section 3: Operation

3.1 General

This section describes the Model 4300-XXX Electric Attitude Indicator operating procedures. The indicator is required to be installed in an aircraft with the specified inputs applied. Figure 1.2 provides an illustration of a typical Model 4300 display and a table describing indicator functions.

3.2 Starting Procedures

The following operational procedures are recommended when preparing the indicator for use:

******CAUTION******

THE INDICATOR MAY BE DAMAGED IF THE "PULL TO CAGE" KNOB IS RELEASED WITH A "SNAP." SLOWLY RELEASE "PULL TO CAGE" KNOB AVOIDING A "SNAP" RELEASE.

NOTE: Indicator may be momentarily caged by pulling "PULL TO CAGE" knob to the fully extended position, holding knob until the display stabilizes, and then allowing the knob to return to the normal position.

- A. Apply power to the indicator. Note that the Gyro Warning flag (red) will pull out-of-view. Allow three minutes for presentation stabilization.
- B. On models with trim adjustment, rotate the symbolic airplane adjustment knob for the desired pitch attitude presentation, i.e. aligning the symbolic airplane with the horizon.
- C. If caging is required, caging should be accomplished when the aircraft is in a wings level, normal cruise attitude, as indicated by other instruments or the earth's horizon. If the gyro is caged when the aircraft is not in this attitude, the resulting attitude presentation immediately after caging will be in error by the difference between true vertical and actual aircraft attitude. Small errors in caging erection will be corrected by the indicator to true vertical in pitch and roll at 2.5° per minute minimum (5°/min. nominal).

3.3 In-Flight Procedures

- A. Adjust the symbolic airplane to obtain desired pitch attitude presentation after take-off.
- B. In the event of errors in excess of 10° caused by extended bank or fore-aft acceleration, the indicator should be momentarily caged after the aircraft is returned to level flight.

3.4 Dynamic Errors

- A. Turn Induced Errors

Pitch indication errors resulting from a standard coordinated turn (180 degrees in one minute at a true airspeed of 156 knots) will not exceed 3°. Dynamic errors developed under non-standard conditions may be greater. Errors that develop will be self corrected by the internal erection system or manually corrected by the actuation of the caging system in straight and level flight.

B. Acceleration & Deceleration Errors

Pitch/roll indicating errors may occur due to accelerations experienced during takeoff, climb-out, descent, and landing. Errors that develop will be self-corrected by the internal erection system or manually corrected (in straight and level flight) by the actuation of the caging system.

C. Taxiing Errors

A pitch and roll indicator display error of approximately 1° will occur during a sudden 90° ground turn. A pitch indicator display error of approximately 2° will occur during a sudden 180° ground turn. Errors that develop will be self corrected by the internal erection system or manually corrected by the actuation of the caging system when aircraft is straight and level.

3.5 Standby Battery Operation

Supply aircraft power to the instrument. The internal standby battery charges automatically while the gyro is running. Lighting is on a separate circuit connected to the aircraft lighting bus.

A. Normal Flight

At loss of external power, an amber LED will flash indicating a Power Loss Warning. With no further action from the pilot, the unit will turn off automatically (gyro flag in view) after approximately one minute. This is to prevent battery discharge at the end of a flight when the master power switch is placed in the off position.

B. Loss of Aircraft Power

When the instrument switches to Power Loss Warning, the amber LED flashes for approximately one minute. This is intended to attract the pilot's attention and indicate that there has been a loss of primary power to the 4300 Attitude Indicator. Pushing the STBY PWR button on the face of the instrument will allow the unit to continue operating on the standby battery for nominally one (1) hour or until the battery is exhausted. See Figure 3.1 for more information on battery discharge rate. The gyro warning flag remains out of view, which indicates the gyroscope is valid and running on standby battery power. An independent standby dial lighting system also operates in this mode.

Any time aircraft power is absent, with the unit in either Power Loss Warning or shut off, pushing the STBY PWR button will put the unit in the standby power mode. The instrument will run from standby power until the standby battery is exhausted. If the unit is running on the standby battery, pushing the STBY PWR button will turn the unit off. Pushing the STBY PWR button again will restore standby power and standby lighting.

Restoring aircraft power will clear any standby operation and resume automatic battery charging.

C. Standby Battery Test

The control panel on the front of the instrument incorporates a manual test feature. This test feature places the standby battery pack under load for approximately one minute (the gyro is used as a load) while displaying either a red or green light under the word TEST on the front panel.

To initiate this test:

1. Turn on the indicator with aircraft power and allow the unit to spin up for 3 minutes or more
2. Press and hold the STBY PWR button. After several seconds the amber LED will start flashing, indicating unit has latched into Battery Test Mode. The test runs for approximately one minute, during which time the amber LED flashes continuously and either a red or green light is displayed under the word TEST.
3. Visually monitor the test lights until the amber LED stops flashing, signaling the end of the test.
4. A green light throughout the test indicates the standby battery pack is healthy and should be able to function normally. A red light at any time during the test means that the standby battery is at least in need of charging, and possibly of replacement.

Note:

A green light throughout this short test does not guarantee that a full hour of operation time is available. Actual operation time on the battery may vary considerably depending on temperature, charge status, and battery condition. (See Section 3.6 for more details).

Complete charging may be required to bring the battery up to full charge if it has been stored for more than four months or if it has been partially discharged. If a steady red light is observed at any time during the test, charge the standby battery completely, using one of the methods described in Section 2.6 and retest the battery. If after charging, the test still fails, service may be required.

It is not recommended to test the battery when aircraft power is not available, but it is possible to put the indicator into test mode while operating on the backup battery. The test will run, but the indicator will turn off at the end of the test period. To turn the indicator back on, simply push the STBY PWR button again.

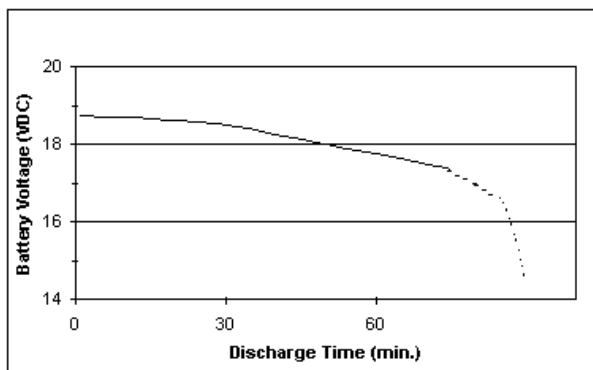

Mod 0

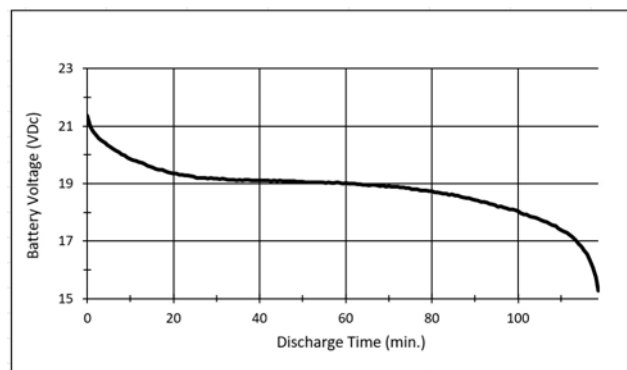

Mod 1

Figure 3.1: Nominal Battery Discharge Rate at 20°C

3.6 Equipment Limitations

The Mid-Continent 9015607 battery pack is part of a complete system. When remote mounted, the 9015607 battery pack **MUST** be installed with the Mid-Continent 4300-XXX series Electric Attitude Indicator with Battery Backup in order to be approved as a complete TSO'd system. **This battery is not FAA approved if installed or used in any other way.**

Actual operation time on the battery may vary considerably depending on temperature, charge status, and battery condition. Low temperatures will temporarily degrade battery capacity as shown in Figure 3.2. Internal chemistry will slowly degrade battery capacity over several years of operation as shown in Figure 3.3, even when correctly maintained. A poorly maintained battery will suffer accelerated degradation in excess of the guidelines given in this document. Extended storage in a discharged state or at high ambient temperatures, and over-charging will all permanently damage a battery. Complete charging is required to bring the battery up to full capacity if it has been stored for more than four months or if it has been partially discharged.

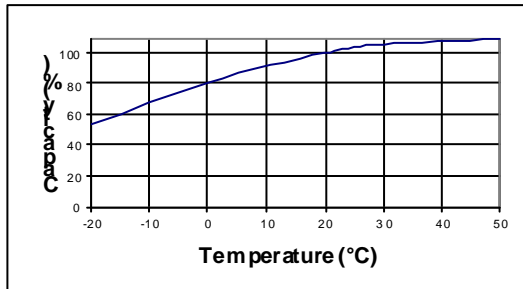

Figure 3.2: Effect of Low Temperature On Standby Battery Capacity

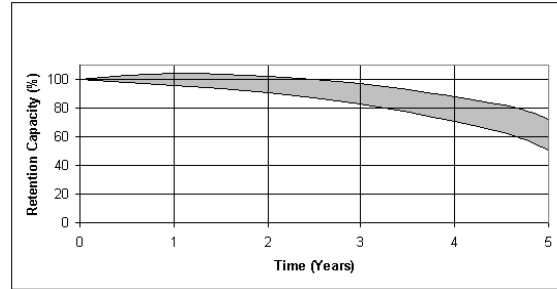

Figure 3.3: Life Characteristics In Standby Use