

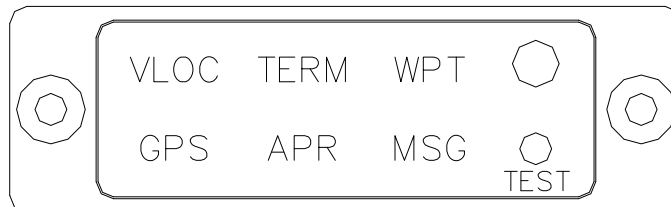

INSTALLATION MANUAL AND OPERATING INSTRUCTIONS

MD41-() Series GPS Annunciation Unit For Garmin GNS 430/530 VHF Communication and Navigation Management System

MD41-1484	14VDC	Horizontal Mount
MD41-1488	28VDC	Horizontal Mount
MD41-1494	14VDC	Vertical Mount (shown on page 10)
MD41-1498	28VDC	Vertical Mount (shown on page 10)



Mid-Continent Instruments and Avionics
9400 E. 34th Street N., Wichita, KS 67226 USA
Phone 316-630-0101 • Fax 316-630-0723

Manual Number 8018277
REV. 2 Dec. 04, 200

Revision Detail

Rev.	Date	Detail
N/R	02-30-2000	Complete issue
1	05-32-2000	Added GNS 530
2	11-28-2006	Added (A), (W) and (TAWS) receivers

TABLE OF CONTENTS

SECTION 1	GENERAL DESCRIPTION
1.1	INTRODUCTION
1.2	SPECIFICATIONS, TECHNICAL
1.2.1	PHYSICAL CHARACTERISTICS
1.2.2	ENVIRONMENTAL CHARACTERISTICS
1.2.3	SPECIFICATIONS, ELECTRICAL
1.2.4	FRONT PANEL CONTROLS AND ANNUNCIATIONS
1.2.4.1	CONTROLS
1.2.4.2	ANNUNCIATIONS
1.2.5	INTERFACE
1.2.6	EQUIPMENT LIMITATIONS
1.2.7	MAJOR COMPONENTS
SECTION 2	INSTALLATION CONSIDERATIONS
2.1	COOLING
2.2	EQUIPMENT LOCATION
2.3	ROUTING OF CABLES
SECTION 3	INSTALLATION PROCEDURE
3.1	GENERAL INFORMATION
3.2	UNPACKING AND INSPECTING
3.3	MOUNTING THE MD41-()
3.4	INSTALLATION LIMITATIONS
SECTION 4	POST INSTALLATION CHECKOUT
4.1	PRE-INSTALLATION TEST
4.2	OPERATING INSTRUCTIONS
FIGURE NO.	LIST OF ILLUSTRATIONS
3.1	SCHEMATIC PINOUT, 9 PIN DSUB
3.2	OUTLINE DRAWING
3.3	INSTRUMENT PANEL MOUNTING
3.4	WIRING DIAGRAM, MD41-1484/1488/1494/1498

APPENDIX

ENVIRONMENTAL QUALIFICATION FORM

SECTION 1 GENERAL DESCRIPTION

1.1 INTRODUCTION

The MD41-() is a compact, self-contained GPS Annunciation unit. This unit displays status annunciation received from the Garmin GNS 430/530 series GPS navigation management systems.

Features include dual 20,000 hour lamps used for all annunciations along with automatic photocell dimming. An external annunciation dimming adjustment is provided for balancing low level light conditions.

NOTE:

The MD41-1484/1488/1494/1498 does not meet all the required status annunciation and mode selection if the GNS 430/530 is considered out of the pilots view. Please refer to the appropriate Garmin installation manual

1.2 SPECIFICATIONS, TECHNICAL

1.2.1 PHYSICAL CHARACTERISTICS

Mounting:	Front mount, panel
Width:	2.45 Inches
Height:	.75 Inches
Depth:	2.60 max Inches
Weight:	0.50 lbs.

1.2.2 ENVIRONMENTAL CHARACTERISTICS

TSO Compliance:	TSO C129
Applicable Documents:	RTCA DO-160C, DO-208
Operating Temperature Range:	-55°C to +70°C
Humidity:	95% Non-Condensing
Altitude Range:	0 to 55,000 ft.
Vibration:	Cat. M and N
Operational Shock:	Rigid Mounting, 6 G Operational 15 G Crash Safety

1.2.3 SPECIFICATIONS, ELECTRICAL

Design	All Solid State
MD41-1484/1494 (14VDC)	0.30 Amps
MD41-1488/1498 (28VDC)	0.25 Amps

1.2.4 FRONT PANEL CONTROLS AND ANNUNCIATIONS

1.2.4.1 ANNUNCIATIONS

VLOC	NAV or ILS information presented on the HSI or CDI.
GPS	GPS information presented on the HSI or CDI.
MSG	ON indicates message(s) active.
WPT	ON indicates reaching the arrival waypoint.
TERM	ON indicates aircraft is within 30 miles of departure or arrival airport.
APR	ON indicates the approach is active.

1.2.5 INTERFACE

VLOC annunciation J1 Pin 5	Receives ground from GNS 430/530 when in VOR/ILS mode
GPS annunciation J1 Pin 9	Receives ground from GNS 430/530 when in GPS mode.
TERM annunciation J1 Pin 4	Requires a logic low to annunciate
APR annunciation J1 Pin 8	Requires a logic low to annunciate
WPT annunciation J1 Pin 3	Requires a logic low to annunciate
MSG annunciation J1 Pin 7	Requires a logic low to annunciate
Lamp Test J1 Pin 2	Receives ground from remote test switch to light all annunciations. (optional connection)

1.2.6 EQUIPMENT LIMITATIONS

The MD41-1484/1488/1494/1498 does not meet all the required status annunciation and mode selection if the GNS 430/530 is considered out of the pilots view. Please refer to the appropriate Garmin installation manual

The MD41-() series control units contain specific dash numbers to be used with various GPS receivers or Navigation Management Systems. The installer must match the correct controller part number with the system being installed.

The conditions and tests required for TSO approval of this article are minimum performance standards. It is the responsibility of those desiring to install this article either on or within a specific type or class of aircraft to determine that the aircraft installation conditions are within the TSO standards. The article may be installed only if further evaluation by the applicant documents an acceptable installation and is approved by the Administrator.

The MD41-1484, -1488, -1494, -1498 is TSO'D and certified for use with the Garmin GNS 430/530 system. This includes the (A), (W) and TAWS systems Any attempts to install the listed units in an installation other than the GNS 430/530 system is prohibited. **This will void the TSO.**

NOTE: If the MD41-() is disconnected or removed from the aircraft, there will be no effect in the operation of the GNS 430/530.

1.2.7 MAJOR COMPONENTS

This system is comprised of one major component, the MD41-1484/1488/1494/1498 series GPS Annunciation Control Unit.

SECTION 2 INSTALLATION CONSIDERATIONS

2.1 COOLING

No direct cooling is required. As with any electronic equipment, overall reliability may be increased if the MD41-() is not located near any high heat source or crowded next to other equipment. Means of providing a gentle air flow will be a plus.

2.2 EQUIPMENT LOCATION

The MD41-() must be mounted as close to the pilot's field of view as possible. The preferable location is near the HSI/CDI that will be displaying the GPS/VLOC information. The unit depth, with connector attached, must also be taken into consideration. Note: Unlike previous versions of the MD41 Annunciation Control Units (ACU), the transfer relays are not required since all switching between GPS, VOR and ILS is handled by the GNS 430/530. This has allowed a for a smaller size ACU which now provides more options for panel mounting.

2.3 ROUTING OF CABLES

Care must be taken not to bundle the MD41-() logic and low level signal lines with any high energy sources. Examples of these sources include 400 HZ AC, Comm, DME, HF and transponder transmitter coax. Always use shielded wire when shown on the installation print. Avoid sharp bends in cabling and routing near aircraft control cables.

SECTION 3 INSTALLATION PROCEDURES

3.1 GENERAL INFORMATION

This section contains interconnect diagrams, mounting dimensions and other information pertaining to the installation of the MD41-(). After installation of cabling and before installation of the equipment, ensure that power is applied only to the pins specified in the interconnect diagram.

3.2 UNPACKING AND INSPECTING EQUIPMENT

When unpacking equipment, make a visual inspection for evidence of damage incurred during shipment. The following parts should be included:

1. MD41-1484 (14volt) or MD41-1488 (28volt) Horiz. Mount
MD41-1494 (14volt) or MD41-1498 (28volt) Vert. Mount
2. Installation kit P/N 8018525 consisting of the following items:
 - A. J1 Connector Kit (9 pin), MCI P/N 8017287
 - B. 2 ea mounting brackets, MCI P/N 8018483
 - C. 4 ea 4-40x 1/2 pan phillips screws, MCI P/N 8011835
 - D. 2 ea 4-40x 9/16 flat-head phillips screws, MCI P/N 8018608
 - E. 1 ea panel cutout template, MCI P/N 8018954
3. Installation Manual. MCI P/N 8018277

3.3 MOUNTING THE MD41-()

Plan a location in the aircraft for the MD41-() to be mounted as close to the pilot's field of view as possible. The preferable location is near the HSI/CDI that will be displaying the GPS information. Avoid mounting close to heater vents or other high heat sources. Allow a clearance of at least 3 inches from back of unit for plug removal.

Use the dimensions shown in figure 3-3 to prepare opening and screw holes for the ACU. A file template has been provided to use for these measurements and hole cutout. Carefully measure the locations for the screw holes and mark the drill locations with a center-punch. Drill all six holes. A steel template (P/N 8018954) is supplied to aid in locating the holes and cutting out the panel. The template may be mounted to the instrument panel to allow a file to be used to complete the cut-out area. The front plate of the ACU has a recessed area on the back so a flat head screw is not absolutely necessary. Attach the mounting brackets to the rear side of the instrument panel with four 4-40x1/2 pan-head screws. Insert the ACU through the front of instrument panel and fasten with two 4-40 x 9/16 flat-head screws.

3.4 INSTALLATION LIMITATIONS

Wire the aircraft harness according to figure 3-3. Use at least 24 AWG wire for all connections. Avoid sharp bends and routing cable near high energy sources. Care must be taken to tie the harness away from aircraft controls and cables. Normal installation techniques should be applied. Also see equipment limitations, section 1.2.6.

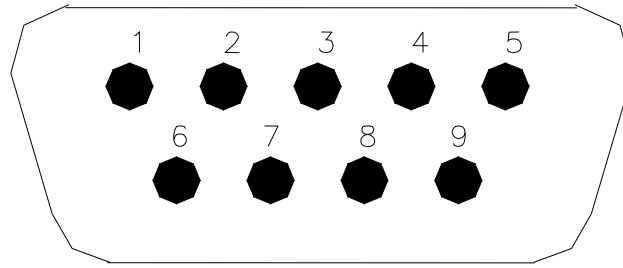

REAR VIEW OF J1 CONNECTOR

J1

PIN NO.

1 -----	14 or 28 VDC UNIT POWER (depends on dash number)
2 -----	LAMP TEST (receives ground from remote test switch)(optional conn.)
3 -----	WPT ANNUNCIATION
4 -----	TERM ANNUNCIATION
5 -----	VLOC ANNUNCIATION
6 -----	POWER GROUND
7 -----	MSG ANNUNCIATION
8 -----	APR ANNUNCIATION
9 -----	GPS ANNUNCIATION

FIGURE 3-1 SCHEMATIC PINOUT, 9 PIN DSUB

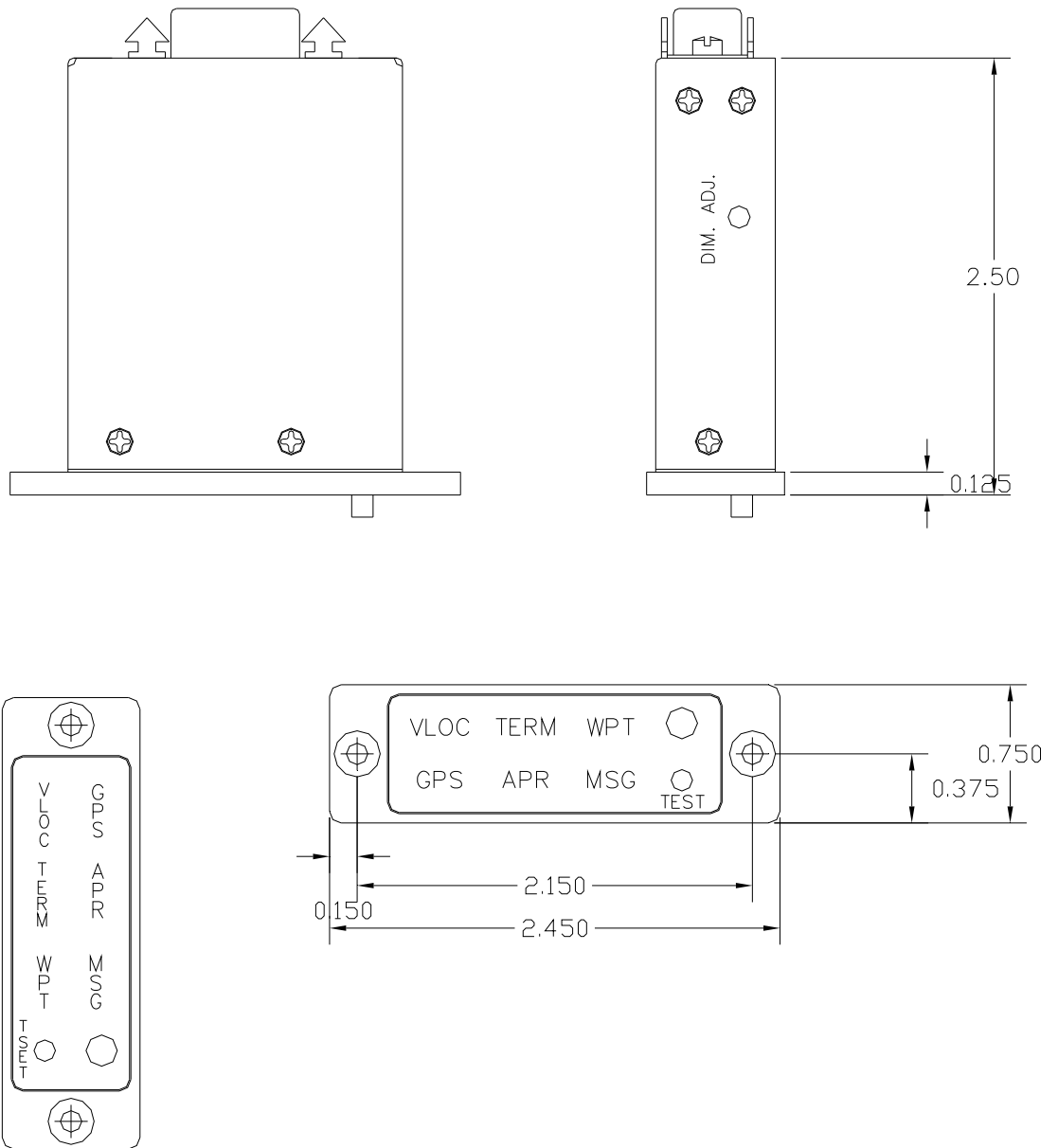
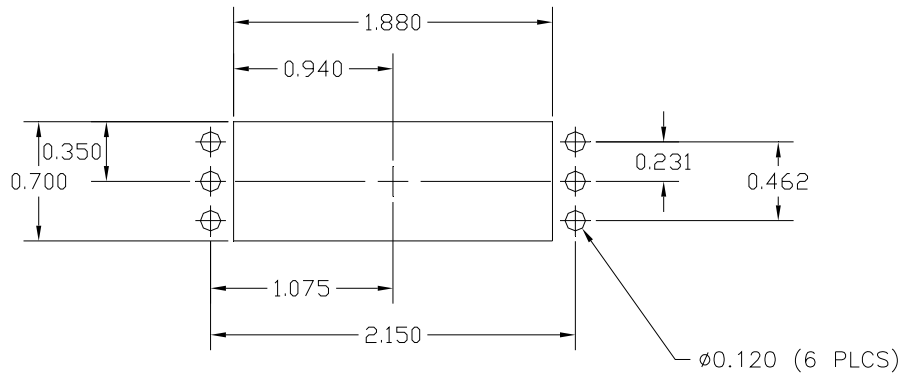
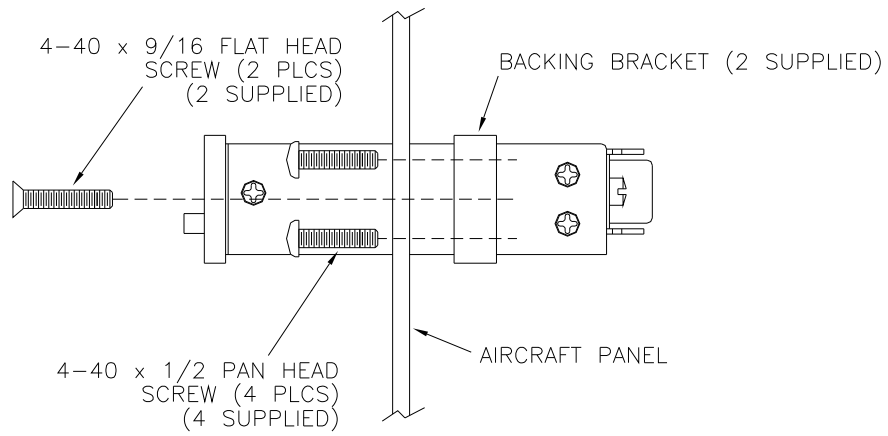

FIGURE 3-2 OUTLINE DRAWING



PANEL CUTOUT



INSTRUMENT PANEL MOUNTING

FIGURE 3-3 INSTRUMENT PANEL MOUNTING

MD41-() ACU
J1

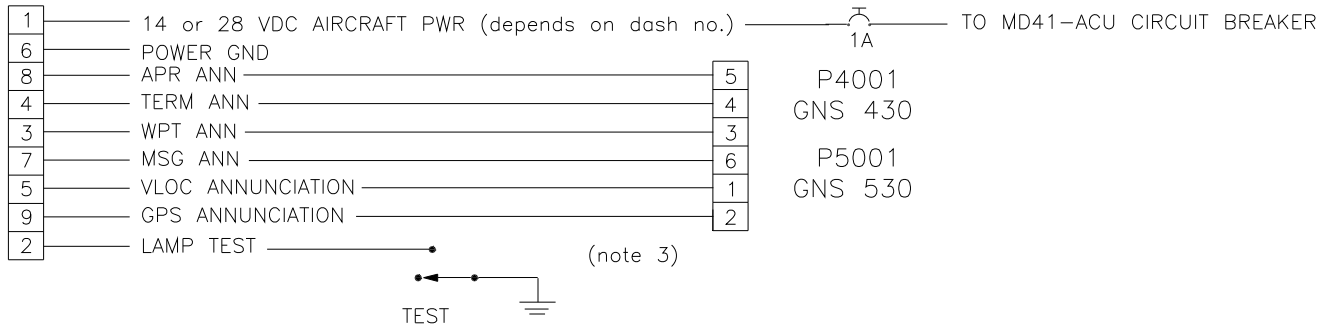

NOTES:

- 1) REFER TO GARMIN GNS 430 or GNS 530 INSTALLATION MANUAL FOR ACTUAL INSTALLATION.
- 2) ALL WIRING SHALL BE 24 AWG UNLESS OTHERWISE NOTED.
- 3) MOMENTARY SWITCH FOR TEST. (optional connection)

**FIGURE 3-4 WIRING DIAGRAM, MD41-1484/1488/1494/1498
For GARMIN GNS 430/530**

SECTION 4 POST INSTALLATION CHECKOUT

4.1 PRE INSTALLATION TESTS

With the MD41-() disconnected, turn on the avionics master switch and verify that aircraft power is on pin 1 for. Using an ohm meter, verify pin 6 is aircraft ground.

4.2 OPERATING INSTRUCTIONS

Turn off the avionics master switch and connect the mating connector to the MD41-(). Turn on the avionics master switch and the MD41-() should come on with the following annunciations.

1. VLOC or GPS
2. MSG may be flashing depending on the status of the GPS receiver.

Press the lamp test button. All annunciations should light. Continue pressing the lamp test button and cover the photocell window located in the center of the front panel. All annunciations should dim.

Annunciation brightness at the minimum dimming level may be adjusted by rotation of the dimmer control located on the bottom of the MD41-() case. CW rotation lowers the dimming level.

Refer to section 5 of the Garmin GNS 430 or GNS 530 installation manual for testing of annunciations.

No periodic maintenance or calibration is necessary for continued airworthiness of the MD41-().

ENVIRONMENTAL QUALIFICATION FORM
RTCA / DO160C

NOMENCLATURE: MD41-() GPS ANNUNCIATION CONTROL UNIT

MODEL NO: MD41-()

TSO NO: C129

CLASS A1

MANUFACTURER TEST SPECIFICATION:

MPS 7015613

MANUFACTURER: Mid-Continent Instruments and Avionics
9400 E. 34th Street N.
Wichita, KS 67226
Phone (316) 630-0101

Conditions	Section	Description of Conducted Tests
Temperature and Altitude	4.0	Equipment tested to Categories A1 & F2 except as noted Cooling air not required Not Tested
Low Temperature	4.5.1	
High Temperature	4.5.2 & 4.5.3	
In-Flight Loss of Cooling	4.5.4	
Altitude	4.6.1	
Decompression	4.6.2	
Overpressure	4.6.3	
Temperature Variation	5.0	Equipment tested to Category B
Humidity	6.0	Equipment tested to Category A
Shock	7.0	Equipment tested per DO-160C Par. 7.2.1
Operational	7.2	
Crash Safety	7.3	
Vibration	8.0	Equipment tested without shockmounts to Categories M and N (Table 8-1)
Explosion	9.0	Equipment identified as Category X, no test required
Waterproofness	10.0	Equipment identified as Category X , no test required
Fluids Susceptibility	11.0	Equipment identified as Category X, no test required

Environmental Qualification (cont.)

Conditions	Section	Description of Conducted Tests
Sand and Dust	12.0	Equipment identified as Category X, no test required
Fungus	13.0	Equipment identified as Category X, no test required
Salt Spray	14.0	Equipment identified as Category X, no test required
Magnetic Effect	15.0	Equipment tested to Class Z
Power Input	16.0	Equipment tested to Category B
Voltage Spike	17.0	Equipment tested to Category A
Audio Frequency Susceptibility	18.0	Equipment tested to Category B
Induced Signal Susceptibility	19.0	Equipment tested to Category A
Radio Frequency Susceptibility	20.0	Equipment tested to Category T
Radio Frequency Emissions	21.0	Equipment tested to Category Z
Lightning Induced Transient Susceptibility	22.0	Equipment identified as Category X, no tests required
Lightning Direct Effects	23.0	Equipment identified as Category X, no tests required
Icing	24.0	Equipment identified as Category X, no test required