



MID-CONTINENT I N S T R U M E N T S

INSTALLATION MANUAL AND OPERATING INSTRUCTIONS

MD41-() Series GPS Annunciation Control Unit for GARMIN GPS 400, GNC 420, GNS 430

MFG. P/N: MD41-1408	28VDC	Horizontal Mount
MFG. P/N: MD41-1404	14VDC	Horizontal Mount
MFG. P/N: MD41-1418	28VDC	Vert. Mount (shown on page 10)
MFG. P/N: MD41-1414	14VDC	Vert. Mount (shown on page 10)

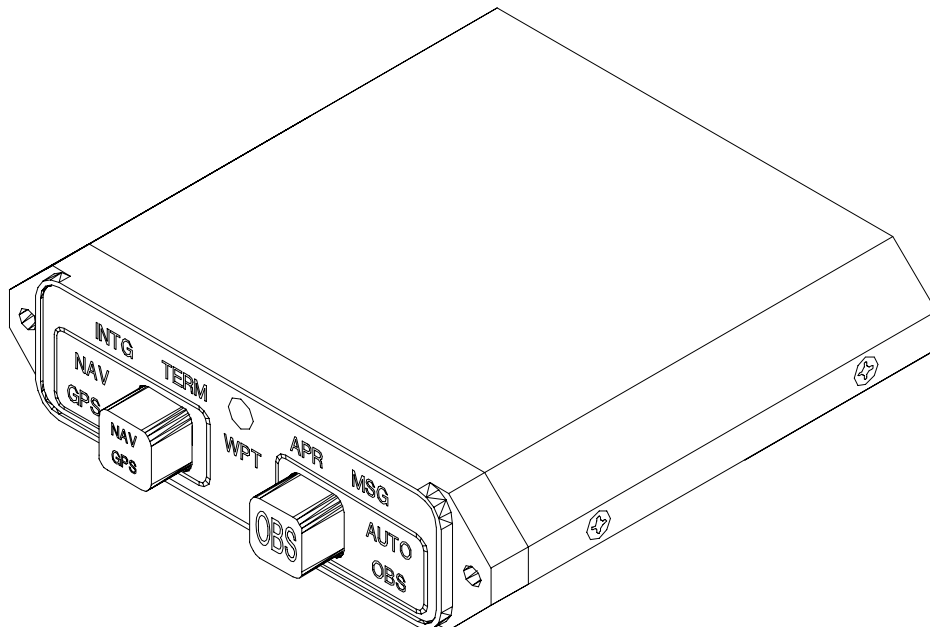

MID-CONTINENT INST. CO., INC
9400 E. 34th Street N., Wichita, KS 67226 USA
Phone 316-630-0101 • Fax 316-630-0723

MANUAL NUMBER 8019358
REV. A, April 26, 2002

TABLE OF CONTENTS

SECTION 1	GENERAL DESCRIPTION
1.1	INTRODUCTION
1.2	SPECIFICATIONS, TECHNICAL
1.2.1	PHYSICAL CHARACTERISTICS
1.2.2	ENVIRONMENTAL CHARACTERISTICS
1.2.3	SPECIFICATIONS, ELECTRICAL
1.2.4	FRONT PANEL CONTROLS AND ANNUNCIATIONS
1.2.4.1	CONTROLS
1.2.4.2	ANNUNCIATIONS
1.2.5	INTERFACE
1.2.6	EQUIPMENT LIMITATIONS
1.2.7	MAJOR COMPONENTS
SECTION 2	INSTALLATION CONSIDERATIONS
2.1	COOLING
2.2	EQUIPMENT LOCATION
2.3	ROUTING OF CABLES
SECTION 3	INSTALLATION PROCEDURE
3.1	GENERAL INFORMATION
3.2	UNPACKING AND INSPECTING
3.3	MOUNTING THE MD41-()
3.4	INSTALLATION LIMITATIONS
SECTION 4	POST INSTALLATION CHECKOUT
4.1	PRE-INSTALLATION TEST
4.2	OPERATING INSTRUCTIONS
FIGURE N0.	LIST OF ILLUSTRATIONS
3.1	SCHEMATIC PINOUT, 25 PIN DSUB
3.2	OUTLINE DRAWING
3.3	WIRING DIAGRAM, MD41-1404/1414 (14Volt), MD41-1408/1418/1408(5V)/1418(5V) (28volt) MD41-244/248

APPENDIX

ENVIRONMENTAL QUALIFICATION FORM

SECTION 1 GENERAL DESCRIPTION

1.1 INTRODUCTION

The MD41-() is a compact, self-contained GPS Annunciation and Control unit. It combines all the necessary functions required to interface the Garmin GPS 400, GNC 420 and GNS 430 approach certified GPS receivers with the MD41-244/248 remote mounted relay transfer system. In addition, the MD41-() contains several GPS status annunciations used to indicate modes selected by the front panel switches and various inputs from the GPS receiver.

A special ILS override feature has been incorporated to cause the MD41-() to automatically switch to the NAV mode when the NAV (VOR) receiver is tuned to an ILS frequency. Other features include dual 20,000 hour lamps used for all annunciations, internally lighted selection switches and automatic photocell dimming. A external annunciation dimming adjustment is provided for balancing low level light conditions.

The MD41-140X/141X series annunciation control unit must be installed with the companion MD41-244/248 series Relay Unit or the AlliedSignal KI 208A/209A course deviation indicator to be approved as a complete TSO'd system.

1.2 SPECIFICATIONS, TECHNICAL

1.2.1 PHYSICAL CHARACTERISTICS

Mounting:	Panel
Width:	3.25 Inches
Height:	0.80 Inches
Depth:	3.20 Inches
Weight:	0.50 lbs.

1.2.2 ENVIRONMENTAL CHARACTERISTICS

TSO Compliance:	TSO C129
Applicable Documents:	RTCA DO-160C, DO-208
Operating Temperature Range:	-55°C to +70°C
Humidity:	95% Non-Condensing
Altitude Range:	0 to 55,000 ft.
Vibration:	Cat. M and N
Operational Shock:	Rigid Mounting, 6 G Operational 15 G Crash Safety

1.2.3 SPECIFICATIONS, ELECTRICAL

Design	All Solid State
MD41-1404/1414 (14VDC)	0.40 Amps
MD41-1408/1418 (28VDC)	0.30 Amps
MD41-1408(5V)/1418(5V) (28DC)	0.30 Amps

1.2.4 FRONT PANEL CONTROLS AND ANNUNCIATIONS

1.2.4.1 CONTROLS

NAV/GPS	Alternate action switch, when pressed, will select NAV (VOR) GPS presentation on HSI
OBS	Momentary action switch, when pressed, will select between AUTO and OBS modes.

1.2.4.2 ANNUNCIATIONS

NAV	NAV (VOR) information presented on the HSI or CDI.
GPS	GPS information presented on the HSI or CDI.
TERM	Annunciated when operating within 30 miles of departure or arrival airport.
APR	GPS is actively engaged in the approach mode.
OBS	This will activate the course selector and also disable the automatic GPS waypoint sequencing.
AUTO	This will disable the course selector input to the GPS and will enable automatic GPS waypoint sequencing.
MSG	GPS message alert, from the GPS receiver.
WPT	GPS waypoint alert, from the GPS receiver.
INTG	Integrity annunciator, illuminates when GPS receiver detects a position error, or is unable to calculate integrity of position.

1.2.5 INTERFACE

NAV annunciation J1 Pin 2	Receives ground from transfer relay when relays are in NAV mode.
GPS annunciation J1 Pin 1	Receives ground from transfer relay when relays are in GPS mode.

1.2.5 INTERFACE (cont.)

Lamp Test J1 Pin 7	Receives ground from remote test switch to light all annunciations.(optional conn.)
TERM annunciation J1 Pin 3	Receives a logic low from the GPS receiver to annunciate TERM.
OBS select J1 Pin 12	Provides a logic low to the GPS receiver when OBS is depressed.
APR annunciation J1 Pin 9	Receives a logic low from the GPS receiver when is active on the approach.
MSG and WPT annunciation	A logic low will cause the appropriate annunciation to illuminate. GPS receiver must be able to accept 100ma.
ILS Override JI Pin 14	Receives a logic low from the NAV (VOR) receiver when tuned to an ILS frequency.
INTG annunciation J1 Pin 20	Receives a logic low from the GPS to annunciate Integrity.
0AUTO annunciation J1 Pin 11	Receives a logic low from the GPS to annunciate AUTO.

1.2.6 EQUIPMENT LIMITATIONS

The MD41-() series control units contain specific dash numbers to be used with various GPS receivers. The installer must match the correct controller part number with the GPS receiver being installed.

The conditions and tests required for TSO approval of this article are minimum performance standards. It is the responsibility of those desiring to install this article either on or within a specific type or class of aircraft to determine that the aircraft installation conditions are within the TSO standards. The article may be installed only if further evaluation by the applicant documents an acceptable installation and is approved by the Administrator.

The MD41-1404/1414/1408/1418/1408(5V)/1418(5V) ACU **MUST** be installed with the Mid-Continent Inst. MD41-244/248 remote transfer relay or the AlliedSignal KI 208A/209A course deviation indicator in order to be approved as a complete TSO system. These items will not be TSO'd if one is installed without the other.

The MD41-1404/1414/1408/1418/1408(5V)/1418(5V) is TSO'D and certified for use with the Garmin GPS 400, GNC 420 and GNS 430 GPS systems. Any attempts to install the listed units in an installation other than the listed GPS receivers is prohibited. **This will void the TSO.**

NOTE: Anytime the MD41-() is disconnected or removed from the aircraft, the HSI/CDI will default to NAV (VOR) mode.

1.2.7 MAJOR COMPONENTS

This system is comprised of two major components, the MD41-140X/141X series GPS Annunciation Control Unit and the MD41-244/248 Remote Relay or the AlliedSignal KI 208A/209A course deviation indicator.

SECTION 2 INSTALLATION CONSIDERATIONS

2.1 COOLING

No direct cooling is required. As with any electronic equipment, overall reliability may be increased if the MD41-() is not located near any high heat source or crowded next to other equipment. Means of providing a gentle air flow will be a plus.

2.2 EQUIPMENT LOCATION

The MD41-() must be mounted as close to the pilot's field of view as possible. The preferable location is near the HSI/CDI that will be displaying the GPS information. The unit depth, with connector attached, must also be taken into consideration. Note: Unlike previous versions of the MD41 Annunciation Control Units (ACU), the transfer relays have been removed and are now remotely mounted in a separate package designated as the MD41-244/248 Relay Unit. This has allowed a for a smaller size ACU which now provides more options for panel mounting. For systems that utilize the AlliedSignal KI208A/209A, the transfer relays are internal to the indicator.

2.3 ROUTING OF CABLES

Care must be taken not to bundle the MD41-() logic and low level signal lines with any high energy sources. Examples of these sources include 400 HZ AC, Comm, DME, HF and transponder transmitter coax. Always use shielded wire when shown on the installation print. Avoid sharp bends in cabling and routing near aircraft control cables.

SECTION 3 INSTALLATION PROCEDURES

3.1 GENERAL INFORMATION

This section contains interconnect diagrams, mounting dimensions and other information pertaining to the installation of the MD41-(). After installation of cabling and before installation of the equipment, ensure that power is applied only to the pins specified in the interconnect diagram.

3.2 UNPACKING AND INSPECTING EQUIPMENT

When unpacking equipment, make a visual inspection for evidence of damage incurred during shipment. The following parts should be included:

1. MD41-1404 (14volt) or MD41-1408 (28 volt) Horiz. Mount
MD41-1414 (14volt) or MD41-1418 (28volt) Vert. Mount
MD41-14048(5V) (28volt) 5 volt button lighting Horiz. Mount
MD41-1418(5V) (28volt) 5 volt button lighting Vert. Mount
2. J1 Connector Kit (25 pin). MCI PN 7014517
3. Installation Manual. MCI PN 8019358

3.3 MOUNTING THE MD41-()

Plan a location in the aircraft for the MD41-() to be mounted as close to the pilot's field of view as possible. The preferable location is near the HSI/CDI that will be displaying the GPS information. Avoid mounting close to heater vents or other high heat sources. Allow a clearance of at least 3 inches from back of unit for plug removal.

The indicator is secured in place behind the panel since it is designed for rear mount only. Make a panel cutout as shown in Figure 3-2 Secure the indicator in place with two 4-40 x 3/8 flat head phillips screws.

3.4 INSTALLATION LIMITATIONS

Wire the aircraft harness according to figure 3-3. Use at least 24 AWG wire for all connections. Avoid sharp bends and routing cable near high energy sources. Care must be taken to tie the harness away from aircraft controls and cables. Normal installation techniques should be applied. Also see equipment limitations, section 1.2.6.

J1 CONNECTOR

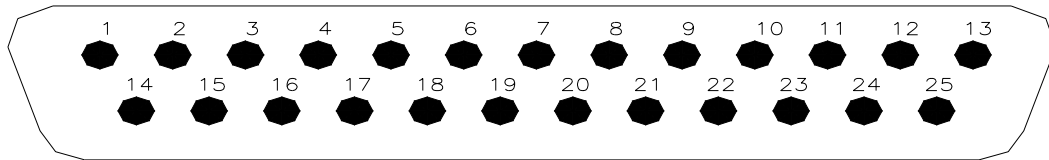

REAR VIEW OF J1 (bottom) CONNECTOR

J1
PIN NO.

1 -----	GPS ANNUNCIATION (receives ground from remote transfer relays)
2 -----	NAV ANNUNCIATION(receives ground from remote transfer relays)
3 -----	TERM ANNUNCIATION (receives logic low from GPS receiver)
4 -----	EXTERNAL RELAY ENERGIZE (provides ground to energize remote transfer relays when GPS is selected)
5 -----	DIMMER IN (from aircraft dimming bus)
6 -----	SPARE
7 -----	LAMP TEST (receives ground from remote test switch)(optional conn.)
8 -----	WPT ANNUNCIATION (receives logic low from GPS receiver)
9 -----	APR ANNUNCIATION (receives logic low from GPS receiver)
10 -----	MSG ANNUNCIATION (receives logic low from GPS receiver)
11 -----	AUTO ANNUNCIATION (receives logic low from GPS receiver)
12 -----	OBS SELECT (logic low to the GPS)
13 -----	14 or 28 VDC UNIT POWER (depends on dash number)
14 -----	ILS FROM NAV (VOR) REC. (for ILS override) (optional)
15 -----	TO NAV CIRCUIT BREAKER (for fault monitoring)
16 -----	SPARE
17 -----	SPARE
18 -----	SPARE
19 -----	SPARE
20 -----	INTG ANNUNCIATION (receives logic low from GPS receiver)
21 -----	SPARE
22 -----	SPARE
23 -----	SPARE
24 -----	OBS ANNUNCIATION (receives logic low from GPS receiver)
25 -----	POWER GROUND

FIGURE 3-1 SCHEMATIC PINOUT, 25 PIN DSUB

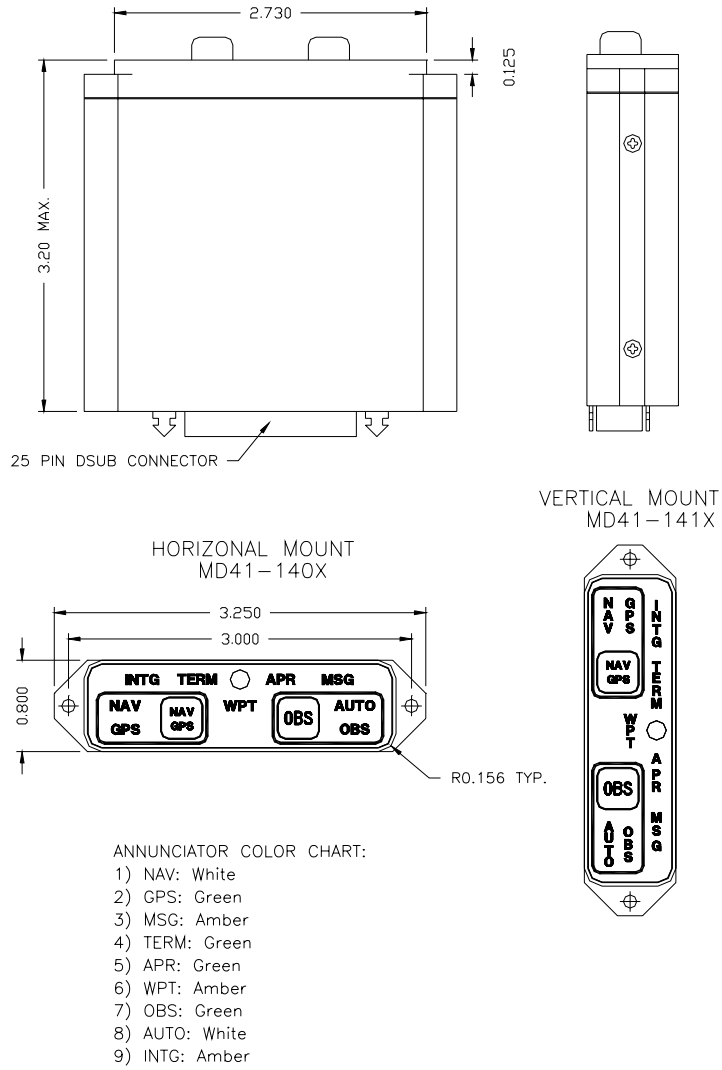

Note 1: Use two 4-40 X 3/8" Flat Head Phillips Screws for Mounting

FIGURE 3-2 OUTLINE DRAWING

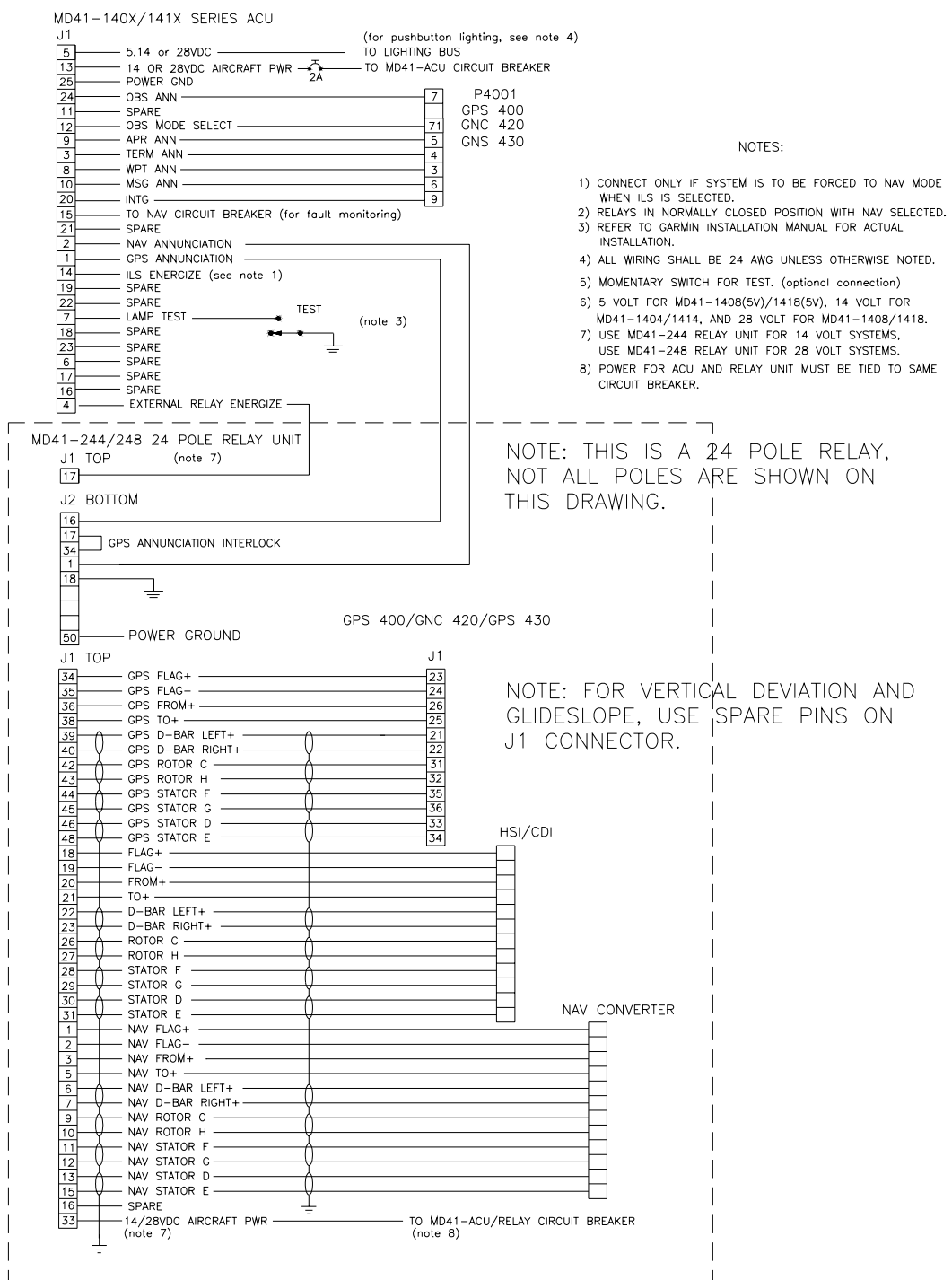

MD41-140X SERIES ACU, RELAY WIRING DIAGRAM

FIGURE 3-3 WIRING DIAGRAM, MD41-1404/1414/1408/1418, 1408(5V)/1418(5V), MD41-244/248 for the GPS 400, GNC 420 and GNS 430 GPS SYSTEMS

SECTION 4 POST INSTALLATION CHECKOUT

4.1 PRE INSTALLATION TESTS

With the MD41-() disconnected, turn on the avionics master switch and verify that aircraft power is on pin 13. Using an ohm meter, verify pin 25 is aircraft ground.

4.2 OPERATING INSTRUCTIONS

Turn off the avionics master switch and connect the mating connector to the MD41-(). Turn on the avionics master switch and the MD41-() should come on with the following annunciations.

1. NAV or GPS
3. MSG may be flashing depending on the status of the GPS receiver.

Press the lamp test button, (if installed) all annunciations should light. Continue pressing the lamp test button and cover the photocell window located in the center of the front panel. All annunciations should dim.

Annunciation brightness at the minimum dimming level may be adjusted by rotation of the dimmer control located on the bottom of the MD41-() case. CW rotation lowers the dimming level.

Select NAV using the NAV/GPS button. The presentation on the HSI/CDI will now be information from the VOR receiver. Using a VOR test generator or equivalent VOR signal, verify that the presentation and operation of the HSI/CDI is correct. This will include course resolver, left-right meter, to-from meter and nav warn flag. Now select GPS on the MD41-() and tune the VOR receiver to an ILS frequency. The MD41-() will be forced to NAV mode and ILS information will be displayed on the HSI/CDI. **NOTE**, this feature will not work if “ILS Energize” (J1 pin 14) was not connected at the time of installation.

Next, verify that OBS and AUTO annunciations will cycle alternately when pressing the OBS button two times. GPS/APR test will not work without a valid GPS signal. Please refer to Section 5 of the Garmin GPS 400, GNC 420 and GNS 430 installation manual for the remaining system tests.

No periodic maintenance or calibration is necessary for continued airworthiness of the MD41-().

ENVIRONMENTAL QUALIFICATION FORM

RTCA / DO160C

NOMENCLATURE: MD41-() GPS ANNUNCIATION CONTROL UNIT

MODEL NO: MD41-()

TSO NO: C129

CLASS A1

MANUFACTURER TEST SPECIFICATION:

MPS 7015613

MANUFACTURER: MID-CONTINENT INSTRUMENT CO., INC.

9400 E. 34th Street N.

WICHITA, KS 67226 PHONE (316) 630-0101

Conditions	Section	Description of Conducted Tests
Temperature and Altitude	4.0	Equipment tested to Categories A1 & F2 except as noted Cooling air not required Not Tested
Low Temperature	4.5.1	
High Temperature	4.5.2 & 4.5.3	
In-Flight Loss of Cooling	4.5.4	
Altitude	4.6.1	
Decompression	4.6.2	
Overpressure	4.6.3	
Temperature Variation	5.0	Equipment tested to Category B
Humidity	6.0	Equipment tested to Category A
Shock	7.0	Equipment tested per DO-160C Par. 7.2.1
Operational	7.2	
Crash Safety	7.3	
Vibration	8.0	Equipment tested without shockmounts to Categories M and N (Table 8-1)
Explosion	9.0	Equipment identified as Category X, no test required
Waterproofness	10.0	Equipment identified as Category X, no test required
Fluids Susceptibility	11.0	Equipment identified as Category X, no test required

Environmental Qualification (cont.)

Conditions	Section	Description of Conducted Tests
Sand and Dust	12.0	Equipment identified as Category X, no test required
Fungus	13.0	Equipment identified as Category X, no test required
Salt Spray	14.0	Equipment identified as Category X, no test required
Magnetic Effect	15.0	Equipment tested to Class Z
Power Input	16.0	Equipment tested to Category B
Voltage Spike	17.0	Equipment tested to Category A
Audio Frequency Susceptibility	18.0	Equipment tested to Category B
Induced Signal Susceptibility	19.0	Equipment tested to Category A
Radio Frequency Susceptibility	20.0	Equipment tested to Category T
Radio Frequency Emissions	21.0	Equipment tested to Category Z
Lightning Induced Transient Susceptibility	22.0	Equipment identified as Category X, no tests required
Lightning Direct Effects	23.0	Equipment identified as Category X, no tests required
Icing	24.0	Equipment identified as Category X, no test required