

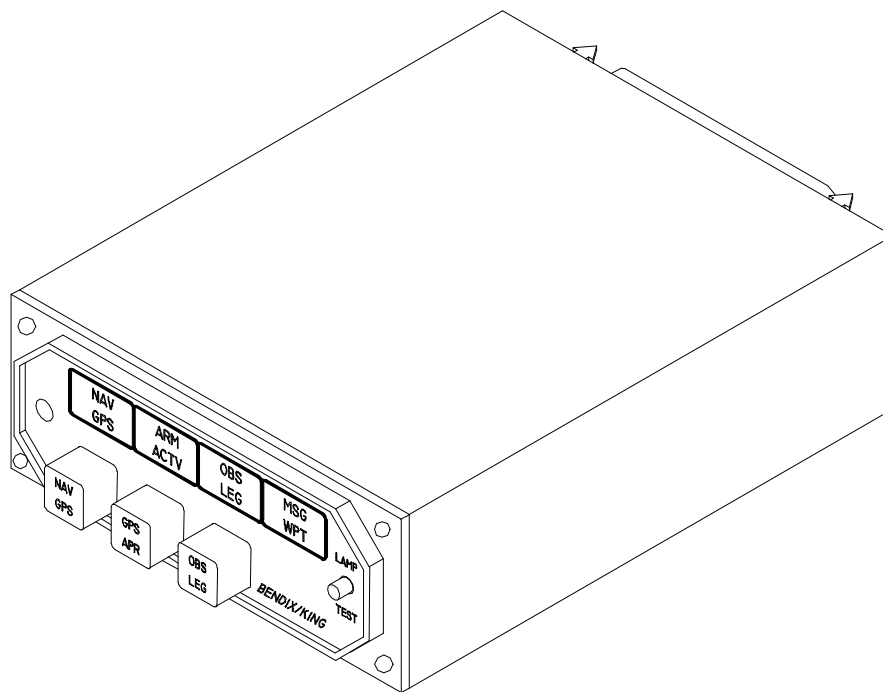

INSTALLATION MANUAL AND OPERATING INSTRUCTIONS

MD41-() Series GPS ANNUNCIATION CONTROL UNIT FOR AlliedSignal KLN 900

| | | |
|-----------|-------|-----------------------------------|
| MD41-928A | 28vdc | Horizontal Mount |
| MD41-938A | 28vdc | Vertical Mount (shown on page 12) |
| MD41-924A | 14vdc | Horizontal Mount |
| MD41-934A | 14vdc | Vertical Mount (shown on page 12) |



Mid-Continent Instruments and Avionics
9400 E. 34TH ST. North, Wichita, KS 67226 USA
Phone 316-630-0101 • Fax 316-630-0723

Manual Number 8016214
REV. 0 Sept. 1, 1998

TABLE OF CONTENTS

| | |
|-------------------|---|
| SECTION 1 | GENERAL DESCRIPTION |
| 1.1 | INTRODUCTION |
| 1.2 | SPECIFICATIONS, TECHNICAL |
| 1.2.1 | PHYSICAL CHARACTERISTICS |
| 1.2.2 | ENVIRONMENTAL CHARACTERISTICS |
| 1.2.3 | SPECIFICATIONS, ELECTRICAL |
| 1.2.4 | FRONT PANEL CONTROLS AND ANNUNCIATIONS |
| 1.2.4.1 | CONTROLS |
| 1.2.4.2 | ANNUNCIATIONS |
| 1.2.5 | INTERFACE |
| 1.2.6 | EQUIPMENT LIMITATIONS |
| 1.2.7 | MAJOR COMPONENTS |
| | |
| SECTION 2 | INSTALLATION CONSIDERATIONS |
| 2.1 | COOLING |
| 2.2 | EQUIPMENT LOCATION |
| 2.3 | ADDITIONAL ANNUNCIATIONS |
| 2.4 | ADDITIONAL RELAYS |
| 2.5 | ROUTING OF CABLES |
| | |
| SECTION 3 | INSTALLATION PROCEDURE |
| 3.1 | GENERAL INFORMATION |
| 3.2 | UNPACKING AND INSPECTING |
| 3.3 | MOUNTING THE MD41-() |
| 3.4 | INSTALLATION LIMITATIONS |
| | |
| SECTION 4 | POST INSTALLATION CHECKOUT |
| 4.1 | PRE-INSTALLATION TEST |
| 4.2 | OPERATING INSTRUCTIONS |
| | |
| FIGURE N0. | LIST OF ILLUSTRATIONS |
| 3.1 | SCHEMATIC PINOUT, 25 PIN DSUB |
| 3.2 | SCHEMATIC PINOUT, 50 PIN DSUB |
| 3.3 | CUTOUT DIMENSION FOR PANEL MOUNTING |
| 3.4 | OUTLINE DRAWING |
| 3.5 | WIRING DIAGRAM, MD41-924A/934A (14V) |
| 3.6 | WIRING DIAGRAM, MD41-928A/938A/928A(5V)/938A(5V) (28V) |
| | |
| | APPENDIX |
| | ENVIRONMENTAL QUALIFICATION FORM |

SECTION 1 GENERAL DESCRIPTION

1.1 INTRODUCTION

The MD41-() is a self-contained GPS Annunciation and Control unit. It combines all the necessary functions required for switching HSI/CDI data inputs between a conventional NAV (VOR) receiver and the Allied Signal KLN 900 approach-certified GPS receiver. In addition, the MD41-() contains several GPS status annunciations used to indicate modes selected by the front panel switches and various inputs from the GPS receiver.

A special ILS override feature has been incorporated to cause the MD41-() to automatically switch to the NAV mode when the NAV (VOR) receiver is tuned to an ILS frequency. Other features include dual, 16,000 hour lamps used for all annunciations, internally lighted selection switches, automatic photocell dimming, and built-in annunciation self test. A external annunciation dimming adjustment is provided for balancing low level light conditions.

A 19 pole relay assembly is included within the MD41-() to simplify installation of the switching between NAV (VOR), GPS and the associated HSI/CDI. All relays have gold plated contacts and are nitrogen filled for high reliability.

Two versions are available that will allow the lighted selection buttons to operate from a 5 volt instrument dimming bus. These part numbers are as follows: MD41-928A(5V) and MD41-938A(5V).

A MD156 adapter plate is available for front mount installations. Also a MD155 punch is available for instrument hole cutout.

1.2 SPECIFICATIONS, TECHNICAL

1.2.1 PHYSICAL CHARACTERISTICS

| | |
|-----------|--------------|
| Mounting: | Panel |
| Width: | 3.50 Inches |
| Height: | 1.350 Inches |
| Depth: | 4.625 Inches |
| Weight: | 0.75 lbs. |

1.2.2 ENVIRONMENTAL CHARACTERISTICS

| | |
|------------------------------|---|
| TSO Compliance: | TSO C129 |
| Applicable Documents: | RTCA DO-160C, DO-208 |
| Operating Temperature Range: | -55°C to +70°C |
| Humidity: | 95% Non-Condensing |
| Altitude Range: | 0 to 55,000 ft. |
| Vibration: | Cat. M and N |
| Operational Shock: | Rigid Mounting, 6 G Operational 15 G Crash Safety. |

1.2.3 SPECIFICATIONS, ELECTRICAL

| | |
|--------------------------------|-----------------|
| Design | All Solid State |
| MD41-924A/934A (14VDC) | 0.65 Amps |
| MD41-928A/938A (28VDC) | 0.40 Amps |
| MD41-928A(5V)/938A(5V) (28VDC) | 0.40 Amps |
| Relay contact current rating: | 2 Amps DC |
| Available relay poles (spdt) | 19 |

1.2.4 FRONT PANEL CONTROLS AND ANNUNCIATIONS

1.2.4.1 CONTROLS

| | |
|-----------|--|
| NAV/GPS | Alternate action switch, when pressed, will select NAV (VOR) or GPS presentation on HSI/CDI. |
| GPS/APR | Momentary switch, when pressed, will arm GPS Approach Mode. |
| OBS/LEG | Momentary action switch, when pressed, will select between OBS and LEG modes. |
| LAMP TEST | Momentary switch for testing annunciation lamps. Note: Screwdriver adjustable control located on right side of case sets annunciator low dimming level. |

1.2.4.2 ANNUNCIATIONS

| | |
|------|--|
| NAV | NAV (VOR) information presented on the HSI or CDI. |
| GPS | GPS information presented on the HSI or CDI. |
| ARM | GPS is armed for automatic transition to approach mode. |
| ACTV | GPS is actively engaged in the approach mode. |
| OBS | This will activate the course selector and also disable the automatic GPS waypoint sequencing to the next leg. |
| LEG | This will disable the course selector input to the GPS and will enable automatic GPS waypoint sequencing to the next leg of the pre-planned route. |
| MSG | GPS message alert, from the GPS receiver. |
| WPT | GPS waypoint alert, from the GPS receiver . |

1.2.5 INTERFACE

| | |
|------------------------------|---|
| APPR ARM Select J1 Pin 24 | Provides a momentary logic low to the GPS receiver when approach arm is selected. |
| APPR ARM J1 Pin 16 | Receives a logic low from the GPS receiver to annunciate ARM. |
| OBS/LEG Select J1 Pin 9 | Provides a momentary logic low to the GPS receiver when OBS is selected. |
| GPS APR ACTV J1 Pin 8 | Receives a logic low from the GPS receiver when a transition is made from arm to active. |
| ILS Override JI Pin 14 | Receives a logic low from the NAV (VOR) receiver when tuned to an ILS frequency. This will force the MD41-() into NAV mode regardless of the NAV/GPS selection. This connection is optional. |
| OBS Annunciate J1 Pin 3 | Receives a logic low from the GPS receiver to annunciate OBS mode. |

1.2.5 INTERFACE (cont.)

| | |
|-----------------------------|---|
| LEG Annunciate J1 Pin 4 | Receives a logic low from the GPS receiver to annunciate LEG mode. |
| MSG and WPT annunciation | A logic low will cause the appropriate annunciation to illuminate. GPS receiver must be able to accept 100ma. |
| GPS DISPLAYED J1 pin 17 | Provides a ground to the GPS receiver when NAV is selected on the MD41-(). |

1.2.6 EQUIPMENT LIMITATIONS

The MD41-() series control units contain specific dash numbers to be used with various GPS receivers. The installer must match the correct controller part number with the GPS receiver being installed.

The conditions and tests required for TSO approval of this article are minimum performance standards. It is the responsibility of those desiring to install this article either on or within a specific type or class of aircraft to determine that the aircraft installation conditions are within the TSO standards. The article may be installed only if further evaluation by the applicant documents an acceptable installation and is approved by the Administrator.

The MD41-924A/928A/934A/938A/928A(5V)/938A(5V) is TSO'D and certified for use with the Bendix/King KLN 900 system. Any attempts to install the MD41-924A/928A/934A/938A/928A(5V)/938A(5V) in an installation other than the Bendix/King KLN 900 is prohibited. **This will void the TSO.**

NOTE: Anytime the MD41-() is disconnected or removed from the aircraft, the HSI/CDI will be inoperative in both NAV (VOR) and GPS.

1.2.7 MAJOR COMPONENTS

The system is comprised of one major component, the MD41-() GPS Annunciation Control Unit.

SECTION 2 INSTALLATION CONSIDERATIONS

2.1 COOLING

No direct cooling is required. As with any electronic equipment, overall reliability may be increased if the MD41-() is not located near any high heat source or crowded next to other equipment. Means of providing a gentle air flow will be a plus.

2.2 EQUIPMENT LOCATION

The MD41-() must be mounted as close to the pilot's field of view as possible. The preferable location is near the HSI/CDI that will be displaying the GPS information. The unit depth, with connector attached, must also be taken into consideration. A MD156 adapter plate is available for front mounting.

2.3 ADDITIONAL ANNUNCIATIONS

Depending upon the installation and approving agency, you may be required to provide additional NAV Source Select external annunciators near the HSI/CDI. Spare relay contacts on the MD41-() J1 or J2 connector may be used for this purpose.

2.4 ADDITIONAL RELAYS

The MD41-() contains 19 relay poles. Some installations may require more than 19 poles due to data lines, superflags etc. If this should occur, you may use one spare relay pole to switch additional relays. In cases where it may be more desirable to have all the relay switching done at a remote location, (i.e.: remote mounted equipment) one relay pole on the MD41-() may be used for switching this bank of relays. Please note that the maximum relay contact rating for the MD41-() is 2 amps DC.

2.5 ROUTING OF CABLES

Care must be taken not to bundle the MD41-() logic and low level signal lines with any high energy sources. Examples of these sources include 400 HZ AC, Comm, DME, HF and transponder transmitter coax. Always use shielded wire when shown on the installation print. Avoid sharp bends in cabling and routing near aircraft control cables.

SECTION 3 INSTALLATION PROCEDURES

3.1 GENERAL INFORMATION

This section contains interconnect diagrams, mounting dimensions and other information pertaining to the installation of the MD41-(). After installation of cabling and before installation of the equipment, ensure that power is applied only to the pins specified in the interconnect diagram.

3.2 UNPACKING AND INSPECTING EQUIPMENT

When unpacking equipment, make a visual inspection for evidence of damage incurred during shipment. The following parts should be included:

1. MD41-924A (14V) or MD41-928A (28V) Horiz. Mount
MD41-934A (14V) or MD41-938A (28V) Vert. Mount
MD41-928A(5V) (28volt) 5 volt button lighting Horiz. Mount
MD41-938A(5V) (28volt) 5 volt button lighting Vert. Mount
2. J1 Connector Kit (25 pin). MCI PN 7014517
3. J2 Connector Kit (50 pin). MCI PN 7014509
4. Installation Manual. MCI PN 8016214
5. 4-40 x 1.0" Mounting Screws, 4ea. MCI PN 7016165

3.3 MOUNTING THE MD41-()

Plan a location in the aircraft for the MD41-() to be mounted as close to the pilot's field of view as possible. The preferable location is near the HSI/CDI that will be displaying the GPS information. Avoid mounting close to heater vents or other high heat sources. Allow a clearance of at least 3 inches from back of unit for plug removal.

The indicator is secured in place behind the panel since it is designed for rear mount only. Make a panel cutout as shown in Figure 3-3. Secure the indicator in place with four 4-40 x 3/8 to 1.0" flat head phillips screws. A MD156 adapter plate is available for front mount installations. Also a MD155 punch is available for hole cutout.

3.4 INSTALLATION LIMITATIONS

Wire the aircraft harness according to figure 3-5 or 3-6. Use at least 24 AWG wire for all connections. You MUST use shielded wire where shown. Avoid sharp bends and routing cable near high energy sources. Care must be taken to tie the harness away from aircraft controls and cables. Normal installation techniques should be applied.

J1 CONNECTOR

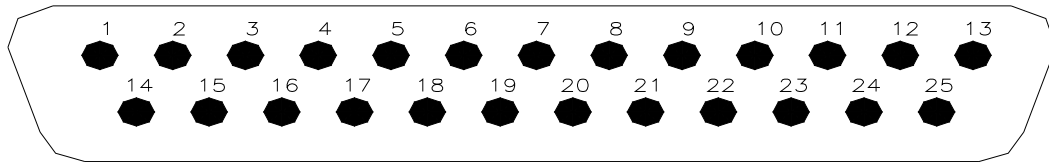

REAR VIEW OF J1 (bottom) CONNECTOR

J1
PIN NO.

| | |
|----------|--|
| 1 ----- | NO7 RELAY |
| 2 ----- | NC7 RELAY |
| 3 ----- | OBS Annunciate |
| 4 ----- | LEG Annunciate |
| 5 ----- | C8 RELAY |
| 6 ----- | NC8 RELAY |
| 7 ----- | NO8 RELAY |
| 8 ----- | GPS APR ACTV ANNUNCIATION |
| 9 ----- | Course Mode Select (obs hold) (momentary low to GPS) |
| 10 ----- | MSG ANNUNCIATION |
| 11 ----- | WPT ANNUNCIATION |
| 12 ----- | 14 VDC UNIT PWR -924A/934A ONLY |
| 13 ----- | 28 VDC UNIT PWR -928A/938A/928A(5V)/938A(5V) ONLY |
| 14 ----- | ILS FROM NAV (VOR) REC. (for ILS override)(optional) |
| 15 ----- | C7 RELAY |
| 16 ----- | APR ARM ANNUNCIATION |
| 17 ----- | GPS DISPLAYED (gnd to GPS) |
| 18 ----- | C5 RELAY |
| 19 ----- | NC5 RELAY |
| 20 ----- | DIM LOW (to lighting bus)(for push-button lighting) |
| 21 ----- | DIM HIGH (to lighting bus)(for push-button lighting) |
| 22 ----- | NO5 RELAY |
| 23 ----- | TO NAV CIRCUIT BREAKER (for fault monitoring) |
| 24 ----- | GPS ARM (momentary logic low to GPS) |
| 25 ----- | POWER GROUND |

FIGURE 3-1 SCHEMATIC PINOUT, 25 PIN DSUB

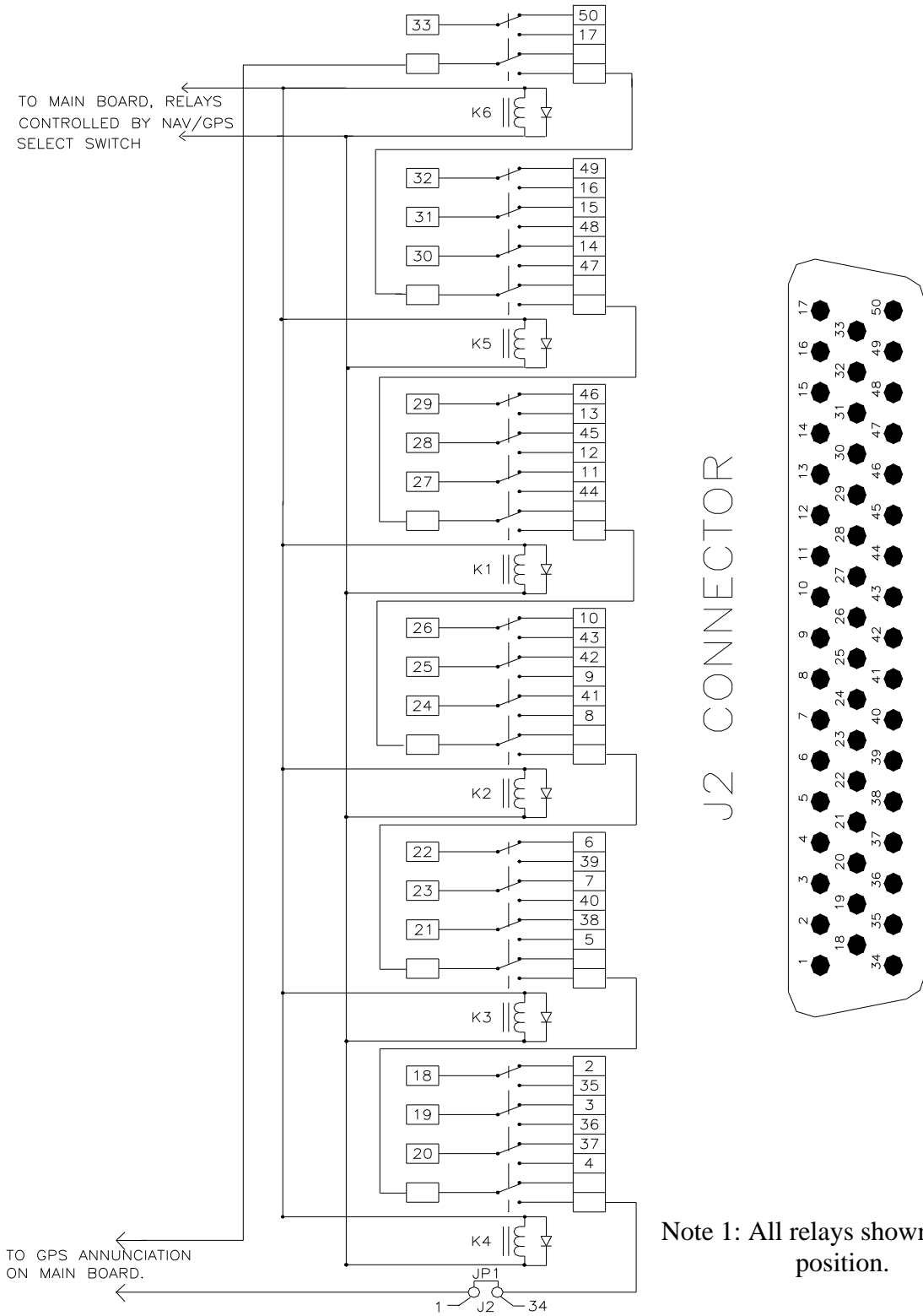
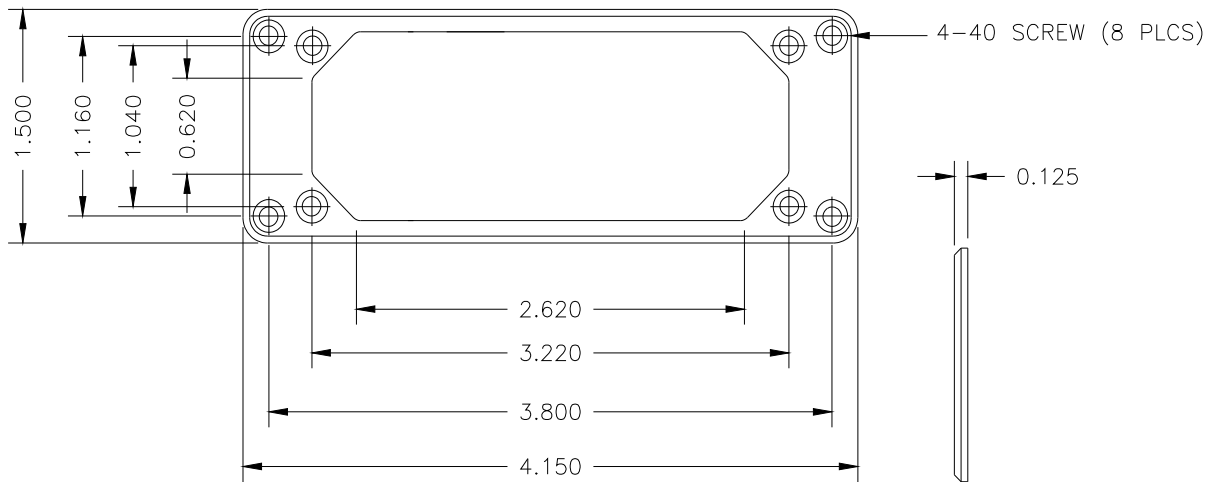
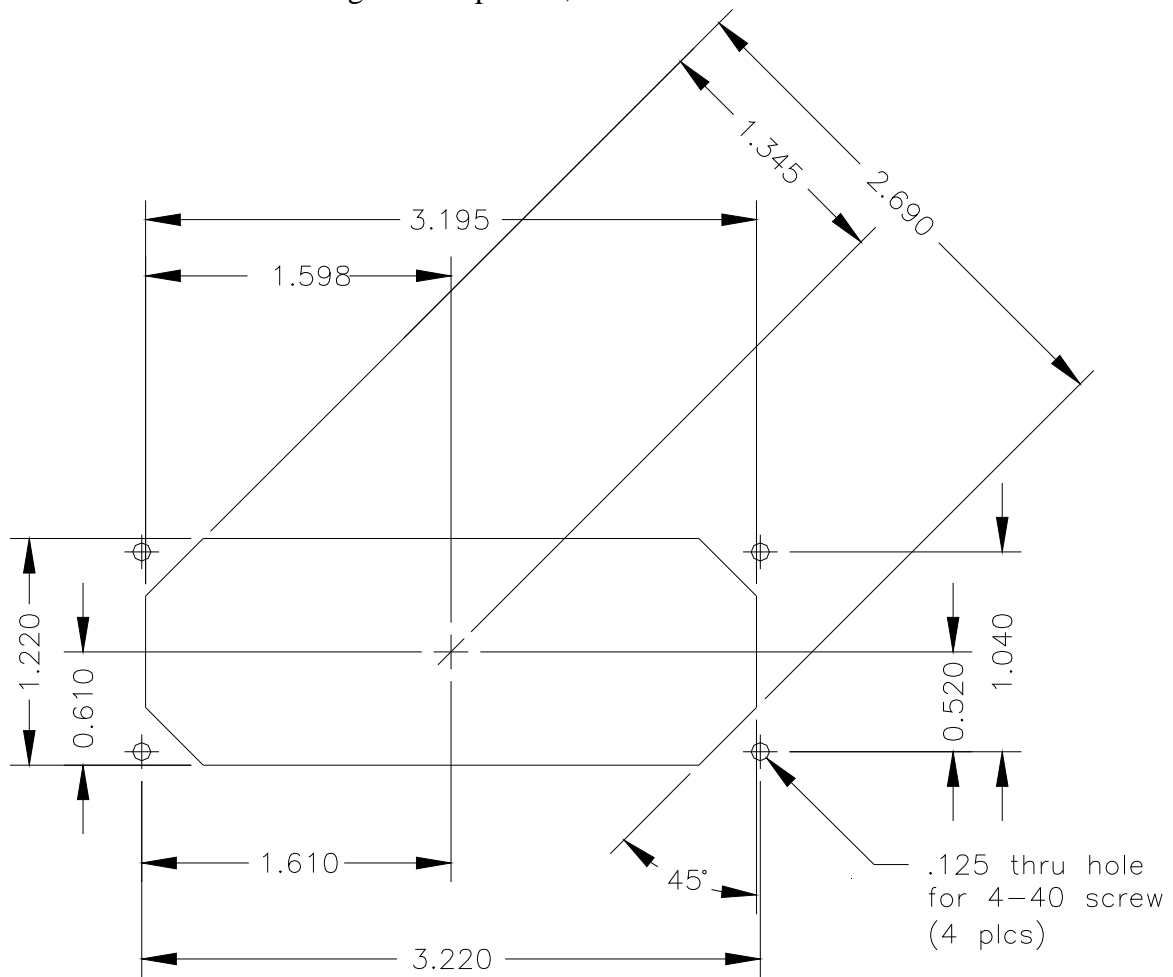

FIGURE 3-2 SCHEMATIC PINOUT, 50 PIN DSUB



MD156 Front Mounting Plate. Optional, must be ordered from Mid-Continent Inst.



ACTUAL SIZE

Note 1: Use four 4-40 X 3/8 to 1.0" Flat Head Phillips Screws for Mounting, MCI PN 7016165 (supplied). MD155 punch is available for hole cutout.

FIGURE 3-3 CUTOUT DIMENSIONS FOR PANEL MOUNTING

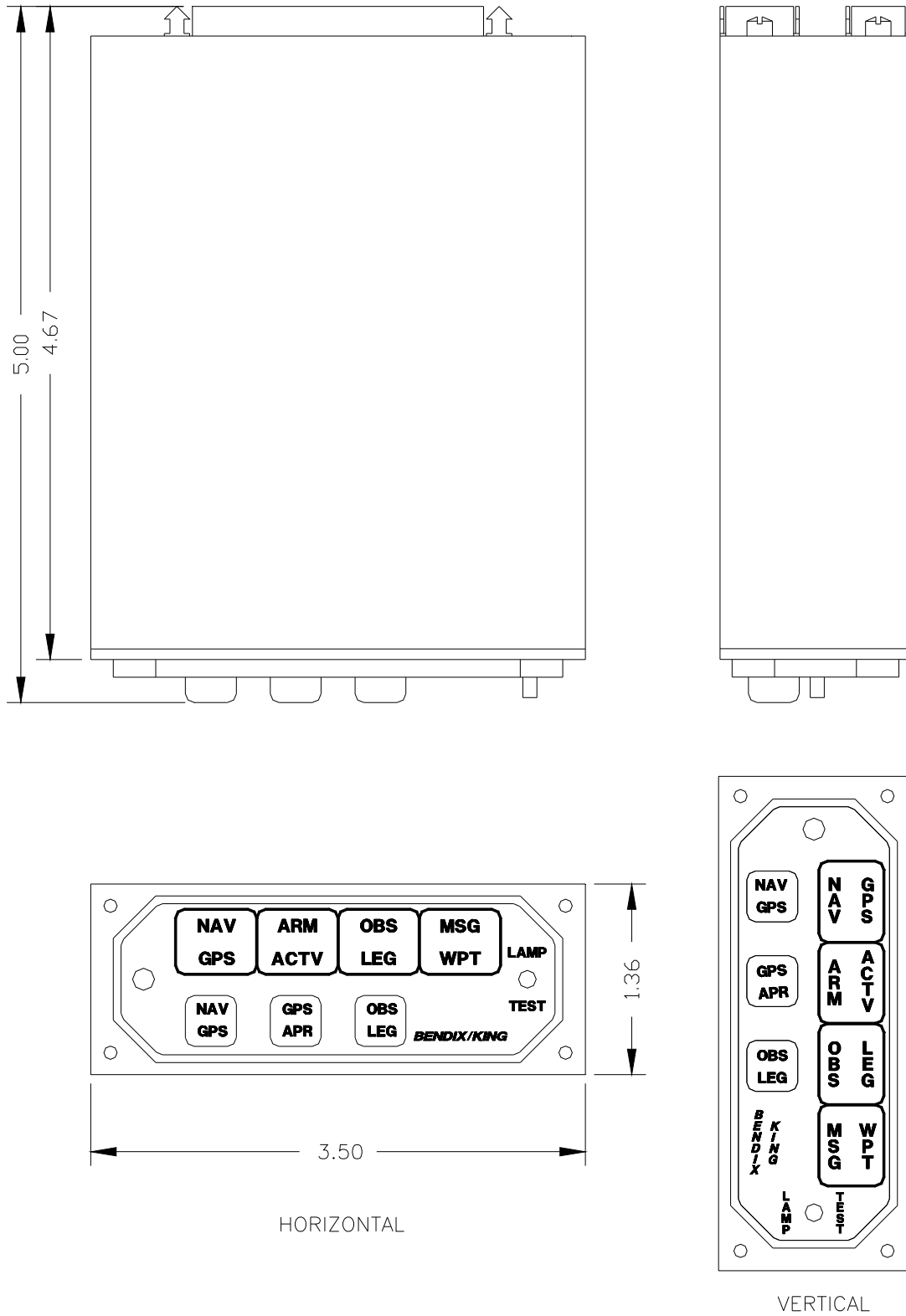
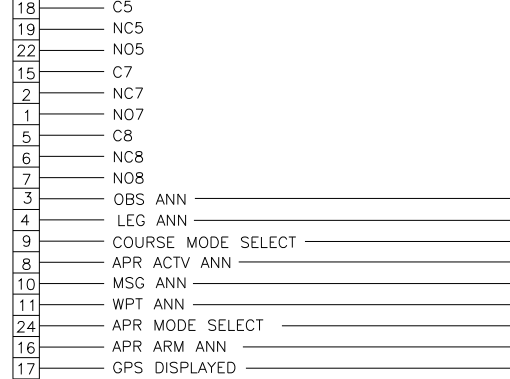
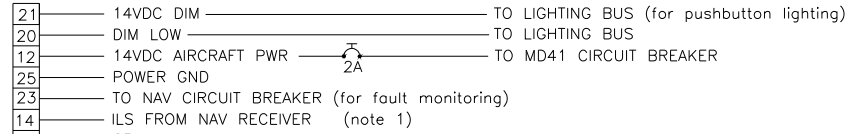

FIGURE 3-4 OUTLINE DRAWING

MD41

J1



KLN 900
P9001

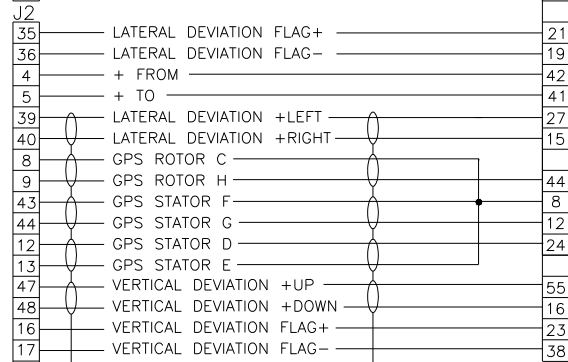

HSI/CDI

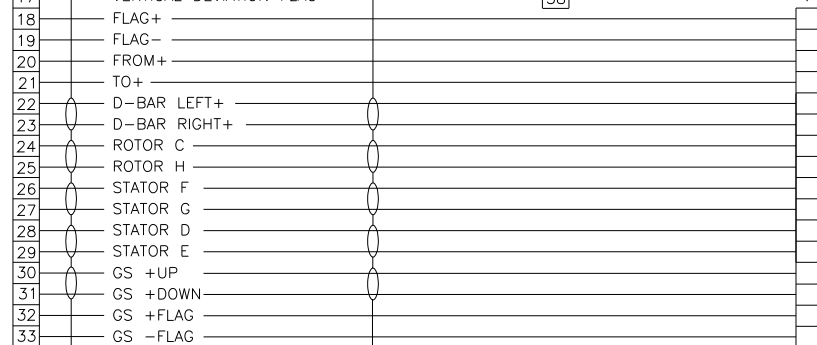

NAV RECEIVER



(note 6)

NOTES:

- 1) CONNECT ONLY IF SYSTEM IS TO BE FORCED TO NAV MODE WHEN ILS IS SELECTED.
- 2) RELAYS IN NORMALLY CLOSED POSITION WITH NAV SELECTED.
- 3) REFER TO BENDIX/KING INSTALLATION MANUAL FOR ACTUAL INSTALLATION.
- 4) RELAYS C5,C7 AND C8 ARE CONTROLLED BY NAV/GPS SELECT SWITCH.
- 5) ALL WIRING SHALL BE 24 AWG UNLESS OTHERWISE NOTED.
- 6) USE INTERLOCK ONLY IF EXTERNAL RELAYS ARE TO BE ADDED. JUMPER MUST BE OPENED INSIDE UNIT ON RELAY BOARD.

FIGURE 3-5 WIRING DIAGRAM, MD41-924A/934A KLN 900 (14V)

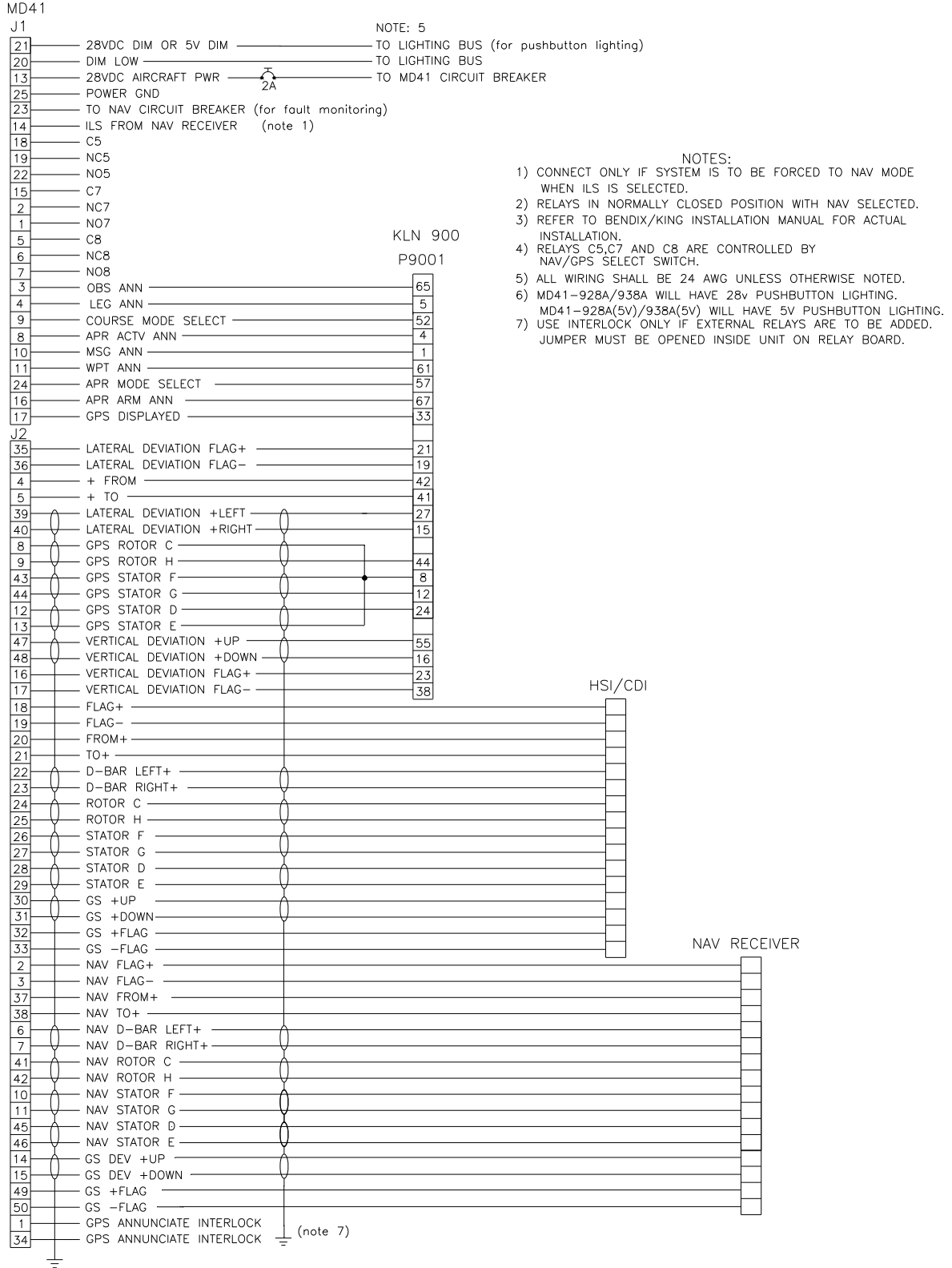

**FIGURE 3-6 WIRING DIAGRAM, MD41-928A/938A/928A(5V)/938A(5V)
KLN 900 (28V)**

SECTION 4 POST INSTALLATION CHECKOUT

4.1 PRE INSTALLATION TESTS

With the MD41-() disconnected, turn on the avionics master switch and verify that aircraft power is on pin 12 for 14VDC systems and pin 13 for 28VDC systems. Using an ohm meter, verify pin 25 is aircraft ground.

4.2 OPERATING INSTRUCTIONS

Turn off the avionics master switch and connect the mating connector to the MD41-(). Turn on the avionics master switch and the MD41-() should come on with the following annunciations.

1. NAV or GPS
2. OBS or LEG
3. MSG and/or WPT may be flashing depending on the status of the GPS receiver.

Press the lamp test button, all annunciations should light. Continue pressing the lamp test button and cover the photocell window located on the left side of the front panel. All annunciations should dim.

Annunciation brightness at the minimum dimming level may be adjusted by rotation of the dimmer control located on the right side of the MD41-() case. CW rotation lowers the dimming level.

Select NAV using the NAV/GPS button. The presentation on the HSI/CDI will now be information from the VOR receiver. Using a VOR test generator or equivalent VOR signal, verify that the presentation and operation of the HSI/CDI is correct. This will include course resolver, left-right meter, to-from meter and nav warn flag. Now select GPS on the MD41-() and tune the VOR receiver to an ILS frequency. The MD41-() will be forced to NAV mode and ILS information will be displayed on the HSI/CDI. **NOTE**, this feature will not work if “ILS Energize” (J1 pin 14) was not connected at the time of installation.

Next, verify that OBS and LEG annunciations will cycle alternately when pressing the OBS/LEG button two times. Press the GPS/APR button and the ARM annunciation will illuminate. ARM can be canceled by pressing the GPS/APR button a second time, or by ACTV input from the GPS receiver. GPS/APR test will not work without a valid GPS signal. Please refer to section 4 of the KLN 900 installation manual for the remaining system tests.

No periodic maintenance or calibration is necessary for continued airworthiness of the MD41-().

ENVIRONMENTAL QUALIFICATION FORM

RTCA / DO160C

NOMENCLATURE: MD41-() GPS ANNUNCIATION CONTROL UNIT

MODEL NO: MD41-()

TSO NO: C129

CLASS A1

MANUFACTURER TEST SPECIFICATION:

MPS 7015613

MANUFACTURER: Mid-Continent Instruments and Avionics
 9400 E. 34th Street N.
 Wichita, KS 67226
 Phone (316) 630-0101

| Conditions | Section | Description of Conducted Tests |
|---|---|--|
| Temperature and Altitude Low Temperature High Temperature In-Flight Loss of Cooling Altitude Decompression Overpressure | 4.0 4.5.1 4.5.2 & 4.5.3 4.5.4 4.6.1 4.6.2 4.6.3 | Equipment tested to Categories A1 & F2 except as noted Cooling air not required Not Tested |
| Temperature Variation | 5.0 | Equipment tested to Category C |
| Humidity | 6.0 | Equipment tested to Category A |
| Shock Operational Crash Safety | 7.0 7.2 7.3 | Equipment tested per DO-160C Par. 7.2.1 |
| Vibration | 8.0 | Equipment tested without shockmounts to Categories M and N (Table 8-1) |
| Explosion | 9.0 | Equipment identified as Category X, no test required |
| Waterproofness | 10.0 | Equipment identified as Category X , no test required |
| Fluids Susceptibility | 11.0 | Equipment identified as Category X, no test required |

Environmental Qualification (cont.)

| Conditions | Section | Description of Conducted Tests |
|--|---------|---|
| Sand and Dust | 12.0 | Equipment identified as Category X, no test required |
| Fungus | 13.0 | Equipment identified as Category X, no test required |
| Salt Spray | 14.0 | Equipment identified as Category X, no test required |
| Magnetic Effect | 15.0 | Equipment tested to Class Z |
| Power Input | 16.0 | Equipment tested to Category B |
| Voltage Spike | 17.0 | Equipment tested to Category A |
| Audio Frequency Susceptibility | 18.0 | Equipment tested to Category B |
| Induced Signal Susceptibility | 19.0 | Equipment tested to Category A |
| Radio Frequency Susceptibility | 20.0 | Equipment tested to Category T |
| Radio Frequency Emissions | 21.0 | Equipment tested to Category Z |
| Lightning Induced Transient Susceptibility | 22.0 | Equipment identified as Category X, no tests required |
| Lightning Direct Effects | 23.0 | Equipment identified as Category X, no tests required |
| Icing | 24.0 | Equipment identified as Category X, no test required |
| | | |
| | | |